

NOT-FOR-PUBLICATION (Commercial)

Safeguard this document as directed overleaf

AEEW R 956



UNITED KINGDOM ATOMIC ENERGY AUTHORITY

Reactor Group

**AN ASSESSMENT OF A 2500 MWe MOLTEN
CHLORIDE SALT FAST REACTOR**

EDITED BY:

J SMITH

W E SIMMONS

CONTRIBUTORS:

DR R C ASHER, AERE

DR G LONG, AERE

DR H A C MCKAY, AERE

DR D L REED

Technical Assessments and Studies Division

NOT FOR PUBLICATION (COMMERCIAL)

AEEW-R 956

AN ASSESSMENT OF A 2500 MWe MOLTEN
CHLORIDE SALT FAST REACTOR

Edited by J Smith
and
W E Simmons

Contributors: Dr R C Asher, AERE
Dr G Long, AERE
Dr H A C McKay, AERE
Dr D L Reed, AEE

Technical Assessments
and Studies Division,
AEE Winfrith

August 1974

W 10774

In the interest of paper
economy this document has
been printed to a reduced
standard.

NOT FOR PUBLICATION (COMMERCIAL)

CONTENTS

	<u>Page No</u>
1. INTRODUCTION	1
2. MSFR CONCEPTS	3
3. CHEMICAL ASPECTS OF THE FUEL	4
4. REACTOR PHYSICS	7
5. SAFETY AND OPERATIONAL ASPECTS	11
5.1 Normal Operation	11
5.1.1 Startup	11
5.1.2 Power Control	11
5.1.3 Hotspots	11
5.1.4 Shutdown	11
5.1.5 Small Leakages	12
5.2 Fault Conditions	12
6. ENGINEERING DESIGN PHILOSOPHY	14
6.1 Choice of Materials	14
6.2 Fuel Inventory	16
6.3 Choice of Intermediate Coolant	17
6.4 Choice of Power Plant	18
6.5 Blanket Inventory and Cooling	19
6.6 Reliability and Maintenance	19
6.7 Engineering Development	20
7. OUTLINE SYSTEM DESIGNS AND AUXILIARY PLANT	21
7.1 General Aspects	
7.2 The Indirectly Cooled Concept	23
7.3 Design Variations of the Indirectly Cooled Concept	24
7.4 Special Auxiliary Plant	25
7.5 Filling, Draining and Dump Systems	25

NOT FOR PUBLICATION (COMMERCIAL)

<u>CONTENTS</u>	<u>Page No</u>
7.6 Emergency Cooling System	26
7.7 Salt Cleanup and Gaseous Fission Product Removal	26
7.8 Processing Plant	28
7.9 Remaining Plant	28
7.9.1 Containment	28
7.9.2 Preheating	29
7.9.3 Shielding	29
7.9.4 Pumps	29
7.9.5 Steam Plant	29
8. MATERIALS	30
9. COSTS	32
9.1 Capital Costs	32
9.2 Fuel Costs	33
9.3 Overall Generating Costs	35
10. CONCLUSION	35
11. PARAMETERS FOR INDIRECT AND DIRECT COOLED VERSIONS OF A MOLTEN SALT FAST REACTOR - SUMMARY	37
REFERENCES	45
ACKNOWLEDGEMENTS	46
APPENDIX I	47
II	53

NOT FOR PUBLICATION (COMMERCIAL)

<u>TABLES</u>		<u>Page No</u>
4.1	COMPARISON OF PERFORMANCE OF REFERENCE MSFR WITH OTHER FAST REACTORS	10
7.1	2500 MW(e) NET MSFR: SUMMARY OF FEATURES	22
A.1	MSFR DIRECT LEAD CURTAIN COOLED SYSTEM - PARAMETERS	49
1	NUCLEAR PERFORMANCE OF A PRELIMINARY UKAEA DESIGN OF AN INTERNALLY COOLED 6000 MW(t) MSFR USING CL37 SALT	56
2	MSFR INTERNALLY COOLED DESIGN PARAMETERS	57

FIGURES

1a	DESIGN 1. INDIRECTLY COOLED MSFR - LEAD COOLANT
1b	ALTERNATIVE DESIGNS FOR INTERMEDIATE HEAT EXCHANGERS FOR LOW CONDUCTIVITY FUEL SALT
2	DESIGN 2. INDIRECTLY COOLED MSFR - LEAD COOLED WITH ALTERNATIVE CORE AND INTERMEDIATE HEAT EXCHANGER LAYOUT.
3	DESIGN 3. INDIRECTLY COOLED MSFR - PRELIMINARY DESIGN OF HELIUM COOLED VERSION.
4	DESIGN 4. DIRECT COOLED MSFR WITH JET PUMP ASSISTED CIRCULATION
4b	SIMPLIFIED DIAGRAM OF DIRECT SYSTEM SHOWING LEAD CURTAIN AND POLOIDAL FLOW
5	GENERAL VIEW OF 2500 MWe MSFR (INDIRECT SYSTEM BASED ON DESIGN 1)
6 & 7	MSFR BUILDING LAYOUT (BASED ON DESIGN 1)
8	SIZE COMPARISON OF MSFR WITH CFR AND MSBR
9	FLOW DIAGRAM - INDIRECT SYSTEM
10	FLOW DIAGRAM-FUEL AND BLANKET SALT CLEANUP AND OFF-GASSING
11	FLOW DIAGRAM - DIRECT SYSTEM
12	INTERNALLY COOLED MSFR

1. Introduction

As a result of some initial studies in 1964 and 1965, it was concluded that the line of investigation of most interest to the UK on molten salt reactors and which would also be complementary to the US investigations would be on a fast reactor version. A preliminary study of a fast system using the U233/Th cycle and fluoride salts did not indicate encouraging results and it was therefore decided that a Pu/U238 cycle would be examined. This involved the use of chloride salts and work on salt chemistry began in 1965 which in 1970 was extended to include additional materials aspects. The assessment and fluid flow study work was carried out mainly in 1971 and 1972. This report presents an overall summary. It is in the nature of a survey report as the limited effort available has meant that the depth to which questions could be investigated has been restricted.

The initial question which is bound to be asked is why consider a fluid fuel, with all the implications of a highly active circuit. If it is considered that the ultimate refinement of the solid fuel system will appear as some form of fast reactor, then to make further progress beyond this, some basic change in concept has to be made, and it seems clear that the most fundamental would be to escape from the trammels of fuel fabrication with fine tolerances, expensive active transport and also from central processing if suitable on-line methods can be developed to treat the fuel directly.

A basic safety feature, in principle, is that a fluid fuel can be disposed of from the reactor to ever-safe containers, while good negative temperature coefficients should limit excursions and potentially offer a self-regulating system. The current feasibility studies have sought to demonstrate how far these potentialities might be realised and to give a preliminary appraisal of the economic and performance prospects. The table below summarises the possible advantages and disadvantages which have become apparent as the investigations have been in progress, and it is hoped this will form a useful reference against which to judge the success achieved to date.

Table I - Advantages and Disadvantages of Molten Salt Fast Reactors (MSFRs)

I. Potential Advantages

1. No loss of neutrons occurs in fuel cladding or structural material in core.
2. Continuous addition or removal of fuel is possible under power.
3. Simple control of power may be achievable by coolant conditions and power demand. It seems possible to avoid control rods or equivalent systems.

NOT FOR PUBLICATION (COMMERCIAL)

4. Strong negative temperature coefficient gives basic safety.
5. High heat capacity of fuel restricts temperature rise on loss of normal cooling. A dump system with independent cooling system can be used for decay heat removal.
6. Reactor vessel is small. Prefabrication of the vessel at works should be possible, thus reducing construction time and interest charges. In the event of a fault in the vessel fuel may be removed and the vessel size is such that its replacement can be contemplated.
7. Building layout is compact due to the small size of the reactor vessel and primary circuit and absence of elaborate fuel handling route.
8. The system can basically be at low pressure apart from pumping pressures.
9. Fuel handling by pumps and pipework should be a simpler operation than solid fuel handling.
10. The system is suited to on-site close coupled fuel processing.
11. A substantial proportion of the fission products can be continuously removed by a close coupled process.
12. Savings in fuel element fabrication and development costs seem possible.
13. Potential for high temperatures and higher cycle efficiency is good.

II Disadvantages

1. Higher fuel inventory than in LMFBRs is required to give heat transfer and transport.
2. Molten salt fuel has relatively poor heat transfer characteristics compared with sodium.
3. The high melting point of suitable fuel salts ($\sim 560^{\circ}\text{C}$) involves pre-heating, and heating to prevent freezing during prolonged shutdowns. The temperatures involved prevent access to plant.
4. The high melting point of the fuel salt also imposes an additional constraint on heat exchanger systems in order to prevent salt freezing on heat transfer surfaces if low return salt temperatures are employed, especially if high heat transfer rates apply on the coolant side.

NOT FOR PUBLICATION (COMMERCIAL)

5. Presence of fission products in the fuel salt - a high standard of plant reliability and leak tightness with remote maintenance is required.
6. Limitation of choice of materials of construction due to corrosion and high temperature.

2. MSFR Concepts

In the main part of this report two versions of the MSFR are considered, which have been designated as the Direct Cooled and the Indirect Cooled systems. Figures 1a and 1b illustrate the second of these, where the fuel salt is pumped through a core vessel of dimensions which permit criticality and in which the fission heat is generated. It then flows through heat exchangers on the secondary side of which is circulated a coolant which transfers the heat to the steam generators. This is the classical pattern of fluid fuel designs and was the form originally considered. However, the investigations at that time considered the circuit hold up and fuel inventory for the layouts examined to be too high and an alternative was sought, emanating from a suggestion by Bettis of ORNL.

In this, the Direct Cooled version (See Figures 4a and 4b), the salt is both cooled and circulated within the core vessel (in what is known as poloidal flow) by a curtain of lead drops injected down the periphery of the vessel. This in principle gives low fuel hold up because no external inventory except that for auxiliary circuits is required. The investigations on this type have focussed on materials aspects and operating conditions, and importantly also, the nuclear and thermal performance. In the course of the study of heat transfer and fluid flow features, it became apparent that there could be substantial limitations on the heat removal capability of the direct scheme, and further problems in achieving the necessary separation of lead and salt at the region where the lead must pass out of the core vessel to the heat exchangers.

For this reason, the Indirect system has been re-examined in the later part of the study, and appears to be of considerable interest, provided that the compact layouts and high heat exchanger volumetric ratings now postulated can be achieved in practice, thus giving a reasonable fuel inventory. The main emphasis in this report is concerned with this latest Indirect version, while details of the Direct system are given in Appendix I.

During the course of this work, a report by Taube ⁽¹⁾ became available which suggested a further alternative in which the heat is removed from the core salt by a heat exchanger system within the core. The coolant is a salt of the same composition as the blanket salt. A preliminary appraisal of this scheme is given in Appendix II.

The reactor cases studied have all been of 6000 MW thermal output. This (equivalent to about 2500 MWe) was chosen as typical of the size of the unit in a large grid system in the later part of the century.

3. Chemical Aspects of the Fuel

The concept of employing a molten salt as the combined fuel and primary coolant of a nuclear reactor presents many novel problems in both reactor design and system chemistry. The achievements of the ORNL Molten Salt Reactor Programme both give confidence in the feasibility of a molten salt concept and lend support to the view that in many important chemical respects a molten salt system can be regarded as being in a state of chemical equilibrium. Much progress can then be made by considering the various equilibria which might occur both within the salt and between the salt and its environment, particularly since many of the equilibria involved are predictable, at least in broad outline.

When selecting a salt mixture for use in the core and blanket of the NSFR many factors, chemical and nuclear, must be taken into account. The reference core salt $\text{NaCl}:\text{UCl}_3:\text{PuCl}_3$ containing in the region of 30 to 40 mole % of heavy atoms (50 to 55 weight%) fulfils the relevant criteria, including melting point ($550\text{-}580^\circ\text{C}$), nuclear properties and chemical stability. Should occasion demand, variations are possible without detracting from its essential properties as a fuel by replacing some or all of the sodium chloride with potassium, magnesium or calcium chlorides.

For the feasibility of the concept it is essential that under all likely conditions throughout the life of the reactor the core and blanket salts should, firstly, be compatible with the container materials and secondly, should not undergo reactions which bring about precipitation, especially of the plutonium, within the reactor. Compatibility is achieved in the initially pure fuel salt by ensuring that materials for the containment are selected from those which form relatively unstable chlorides, such as iron, nickel and the refractory metals. Since the chlorides in the fuel salt are of high stability little reaction with these metals is then expected, and this is borne out by experiment. During reactor operation additional chemical species are introduced into the salt and processes are envisaged in order to maintain their concentrations at some acceptable equilibrium level. Of the important fission products, some are gaseous and can be removed continuously, some, notably Rb, Cs, Sr, Ba, Zr and rare earths, form chlorides and remain the salt while others, notably Mo, Ru and Pd are unstable as chlorides and will precipitate from the salt as metals. Experience in the MSRE suggests that these will in part be discharged as a fog with the inert gases and partly plate out on metal surfaces. In a direct cooled system an additional possibility is dissolution in the lead coolant.

While it is possible that certain individual fission products might take part specific corrosion reactions, as chemical entities the majority of fission products should not significantly modify the corrosion behaviour of the salt and their concentration will be maintained at a level acceptable to neutron economy by chemical reprocessing.

NOT FOR PUBLICATION (COMMERCIAL)

During fission, however, there is mis-match between the number of chlorine atoms available from the fissioned chloride and the number taken up by the fission products. The excess chlorine produced reacts with the strongest reducing agent present, UCl_3 , forming UCl_4 . In the pure form this is highly corrosive, but prediction and experiment both show that when UCl_4 is dissolved in fuel salt at low concentrations little attack of container metals is to be expected. The concentration of UCl_4 is readily maintained at acceptably low levels by reacting the fuel salt at a modest rate with, for example, metallic uranium. By a similar argument, supported by ORNL irradiations of fluoride fuel salts at comparable heat ratings, UCl_3 is expected to react rapidly with any short-lived oxidising species produced under the intense fission fragment irradiation of the salt. Neither evolution of chlorine from the melt nor enhanced attack of the container materials under irradiation are therefore to be expected.

Other specific chemical species which are of interest in compatibility will be present in the melt. The (n,p) reaction on ^{35}Cl will produce ^{35}S at a mean concentration (up to a few thousand ppm in the salt) which depends upon the fuel rating and the isotopic concentration of the chlorine. Account must also be taken of the effect of introducing oxide into the melt by ingress of air or water vapour. The UCl_3 component of the fuel is expected to combine with both the sulphur and the oxygen and so reduce their reactivity towards structural materials. Experimental verification of this point is required, particularly for such materials as nickel which are known to be susceptible to sulphur attack.

Consideration of the stability of corrosion product chlorides, backed by laboratory experience, lead to the conclusion that alloys based on iron, nickel and the refractory metals such as molybdenum will be compatible with chloride fuel and blanket salts in which the UCl_4 contents is maintained at a low level, less than a few percent of the UCl_3 content. More reactive metals such as chromium could in addition be admitted as minor constituents in an alloy provided some surface leaching were allowed for. When lead is also present, as in the direct cooled system, the lead itself is compatible with fuel salt, but the choice of container material is more restricted. Nickel alloys are excluded, while only a limited range of iron alloys is possible. The presently preferred container for the two liquids together is molybdenum, either as bulk material or in the form of a protective clad on an iron-based structure.

The fission process produces chemical species which might lead to precipitation of components from the fuel salt. These include fission products reacting to give complex chlorides (e.g. Cs_2UCl_6) or specific compounds (e.g. UI_4) and the ^{35}S forming sulphides (US). Although not all the relevant solubilities are known it is likely that uranium compounds will precipitate in preference to the corresponding plutonium compounds. Preliminary measurements have confirmed that the material precipitated from a fuel salt containing both uranium and plutonium is largely uranium sulphide.

NOT FOR PUBLICATION (COMMERCIAL)

The solubility of sulphur, however, is much less than the amount estimated to be formed in a natural-chlorine fuelled system. A low solubility of sulphur, or of any of the other uranium-bearing species, would not adversely affect the feasibility of the system. By a simple process - such as adjustment of temperature and UCl_4 content - precipitation could be induced in a clean-up circuit. Since the species concerned are being produced at a predictable rate the concentrations in the core could be safely maintained close to saturation and even an inefficient removal process would suffice. By contrast the adventitious admission of oxygen is likely to be unpredictable. It is therefore necessary firstly to ensure that the fuel salt is capable of dissolving the amounts of oxygen which might conceivably be admitted and secondly to keep the normal oxygen content of the melt well below the saturation level, so maintaining the capacity of the melt to dissolve additional oxygen. Measurements of the oxide solubility have demonstrated an adequate capacity for dissolving oxide, but have also shown that only a small decrease in solubility can be expected when conditions are changed from those normally obtaining in the reactor. The required degree of oxygen removal is therefore not possible by, for example, simple adjustment of the temperature, and alternative chemical methods have been sought. Precipitation of oxygen as alumina by reaction with aluminium, introduced into the salt as the liquid sodium chloraluminatate, has been studied in some detail. This reaction promises to provide not only an efficient method of oxide removal but also a convenient means of converting uranium and plutonium oxides produced in the reprocessing cycle into fuel or blanket salt. In further tests the prediction that from melts containing both UCl_3 and $PUCl_3$ uranium is precipitated as oxide in preference to plutonium has been confirmed over a range of relevant conditions.

In addition to the adjustment of the chemistry of the fuel and blanket salts on a fairly rapid cycle as just described (which will, incidentally, also serve to remove any inert gas fission products not removed in the cover gas), and defined as clean up it is necessary to carry out more drastic processes, probably on a slower cycle defined as processing, whose basic purpose is to remove fission products from the core and plutonium from the blanket. If separated ^{37}Cl is used, this must be recycled without appreciable loss; and may cause problems in the reconversion of heavy metal to chlorides when excess chloride is required. It is also desirable to recycle the sodium in the fuel salt to avoid a radioactive disposal problem.

Two contrasting schemes have been considered to meet these objectives, one based on mainly well-established aqueous processes and the other on a series of pyrochemical steps, each of which has been tested in the laboratory. For the aqueous route it is necessary to develop processes to convert the reprocessed heavy atom content to chloride, as well as, probably, to recover the sodium chloride for recycling. The pyrochemical route uses a series of metal displacement reactions in molten chloride media. The feasibility of such a process has been demonstrated at ANL on a pilot-plant scale for oxide fuels, but much engineering development is required to evolve a workable and reliable process, especially in view of criticality restrictions.

NOT FOR PUBLICATION (COMMERCIAL)

The process can be operated close-coupled to the reactor and on a much shorter cycle than the aqueous route, and the plant is compact. At the present time there is insufficient information to make meaningful cost estimates for this process but the preliminary work that has been done indicates that capital and operating costs may be high because of the small batch type operations needed.

On the other hand, an aqueous reprocessing plant for high burnup fuel cannot economically serve much less than 20 GWe of installed nuclear capacity, although relatively small additions at the head and tail end could be made to such plant used for other fast systems.

To summarise, in exploring both theoretically and experimentally the chemistry of molten chlorides as a fast reactor fuel no practical impediment to their successful application has been found, potential methods of fission product reprocessing and salt clean-up have been identified and some specific reactions of possible future value to the fuel cycle have been developed.

4. Reactor Physics

An important aim of the reactor physics investigations has been to see what form the proposed reactor of 6000 MW(t) to be built around the year 2000 would have to take in order to achieve a doubling time of 15 - 20 years, this figure being judged against forecast doubling times of the generating system as a whole.. However, there is not only considerable uncertainty in this type of forecasting but variation in requirements in different countries.

Furthermore, for example, fuel inventory around the turn of the century may not be such a critical criterion. A range of alternatives was therefore explored.

Throughout the study only salts containing a mixture of (U+Pu) Cl_3 and NaCl were considered. Early in the study it became clear that for the better ranges of nuclear performance consideration would have to be given to the use of chlorine enriched in the Cl-37 isotope and it was found necessary to undertake an evaluation of the cross-section data. For simplicity the initial calculations assumed full enrichment to Cl-37.

To understand the basic physics performance of the MSFR a series of calculations with simple spherical reactor systems was made. The results of this study indicated that:-

- (a) increase in heavy metal content within the salt improves the nuclear performance although the salt becomes more costly and its melting point increases. The composition recommended as a result of this study was 40% (U+Pu) Cl_3 /60% NaCl (this has a melting point of 577°C), the Pu fraction being about 10% of the heavy metal content.

NOT FOR PUBLICATION (COMMERCIAL)

- (b) acceptable breeding gains are not obtained over the range of core sizes consistent with satisfactory fuel ratings unless the core is surrounded by a blanket (initially 40% UCl_3 /60% NaCl) - that is a single-region system did not have adequate performance.
- (c) a blanket thickness of 1m appeared to give a reasonable nuclear performance without leading to excessive blanket salt inventories.
- (d) the breeding gain is increased by a factor of two when natural chlorine is replaced by Cl-37.
- (e) a doubling time* of less than 20 years for the direct cooled system would be obtained if core volumetric ratings could be greater than 270 MW/m^3 with natural Cl or $\sim 100 \text{ MW/m}^3$ with Cl-37 in the salt. For the indirect system, where a large part of the overall fuel inventory is in the external heat removal circuit (see Section 6.2 for a discussion of factors controlling this) doubling times in the region of 20 years can only be achieved if the core volume is reduced until the rating is $\sim 360 \text{ MW/m}^3$, as in the designs shown.
- (f) the temperature coefficient of reactivity and Doppler coefficients are large and negative over the range of operating temperatures considered so giving a means of reactor control.

Indirect Cooled MSFR

A lead cooled reactor with a layout as shown in Figure 1a was analysed in more detail and with high Cl-37 salt the doubling time is ~ 25 years and with natural Cl ~ 44 years. A simple analysis showed that the system should be stable to small reactivity perturbations if the ratio of the core volume to total volume of core salt was greater than $\frac{1}{4}$ and the engineering studies showed that this requirement could be met with a margin. Although it was not possible to carry out more than an elementary analysis of control arrangements, the limited study suggested that control of power level could be achieved by varying the flow rate of salt through the core and heat exchangers, the temperature of the salt remaining essentially constant at all power levels due to the combination of the negative temperature coefficient and the absence of the heat transfer and fuel pin temperature differentials of a solid-fuel reactor.

The results of the studies of the transient behaviour of this reactor with a simplified reactor model showed that the temperature rise of the core salt due to a reactivity step of up to $\$1$ should be less than 300°C , and for 7 pumps failing out of 8 will be less than 230°C . Also the effect of changes in the fraction of delayed neutrons re-entering the core from the external circuit with variation of primary circuit flow rate was assessed to be small.

* All doubling times quoted make a notional allowance for holdup in processing plants.

NOT FOR PUBLICATION (COMMERCIAL)

Direct Cooled MSFR

The initial physics studies of this concept (see Figure 4a for the layout) were based on volumetric rating within the core of 100 MW/m^3 to conform with the limits on heat removal which it was then thought might apply. The performance with natural Cl in the salt was disappointing with a doubling time of ~ 60 years. To improve the doubling time chlorine was replaced by high enrichment Cl-37 and the doubling time obtained was between 20 and 24 years depending on the various core and blanket configurations studied to accommodate flow requirements. To give competitive fuel costs in terms of plutonium and Cl-37 inventory, it would be necessary to reduce the size of the reactor such that the volumetric rating substantially exceeded 100 MW/m^3 . The size eventually chosen for the reference engineering design has a core volume of 40 m^3 (150 MW/m^3 volumetric rating), giving a doubling time, taking account of full fission product absorption, of about 20 years, which could be reduced to 18 years if 40% of the fission products are removed with an on-line process and there is a low reprocessing holdup (i.e., for an in-line plant or quick turn round in a nearby centralised plant). It should however be noted (see Appendix I) that there are serious doubts about heat removal and separation at this rating.

In the original design the loss of the curtain of lead drops (e.g. due to pump failures) increased the reactivity due to replacement of the lead by the salt. But if the proportionate volumes of lead and salt within the core are made to remain constant for all configurations of the lead curtain by ensuring that on loss of flow, the lead remains in a pool at the bottom of the vessel the reactivity was decreased ($\delta k = -0.003$). This effect, together with a negative temperature coefficient of $-6 \times 10^{-5} \frac{\delta k}{k} / ^\circ\text{C}$ gives a possible means of reactivity control by the curtain. An analysis of a series of steady state runs at power levels over the range of interest showed that it was possible, by altering the inlet and outlet temperature, to keep the lead flow constant, thus avoiding the effect of reactivity changes from changes in the geometry of the curtain, and maintaining adequate circulation and separation.

With this method the salt stays at essentially a constant temperature and is slightly perturbed by control of the external lead temperature to control power. Study of short-term and rapid transient behaviour could not be done with the effort available but it seems likely that supplementary control would be needed for this.

Comparison of Fuel Cycle Performance with other Fast Breeder Reactor Schemes

In the Table below, the sodium-cooled fast breeder cases given are considered typical of an oxide-fuelled design and of possible advanced designs using carbide fuel in the core as well as blanket. The two gas-cooled fast reactor cases are taken from recent publications by the Gas Breeder Reactor Association.

NOT FOR PUBLICATION (COMMERCIAL)

The MSFR doubling times are quoted for 65% Load Factor and a reprocessing hold-up time of 9 months, with 2% Pu losses to be comparable to the other cases in the preliminary work, doubling times do not include the plutonium formation for equilibrium blanket conditions. Although the figures for different systems are not on a strictly comparable basis and the reactor sizes are different, it is considered the figures can be used to illustrate the issues adequately.

TABLE 4.1

Comparison of Performance of Reference MSFR with other Fast Reactors

Reactor	Thermal Power MWt	Power Density MWt/m ³	Specific System Inventory Kg Pu ₂₃₉ MWt	Breeding Gain	Doubling Time
1330 MWe LMFBR (Oxide/Carbide/Blanket)	3100	484	1.23	0.18	34
1330 MWe LMFBR (Carbide)	3100	484	1.06	0.33	16
1000 MWe GCFR (Pin)	2720	247	1.54	0.45	13
1000 MWe GCFR (Particle)	2840	421	1.31	0.36	13
2500 MWe Indirectly Cooled MSFR (Cl design 1)	6000	364	1.82*	0.17	44
2500 MWe Indirectly Cooled MSFR (Cl ₃₇ Design 1)	6000	364	1.75*	0.29	25

* Conditions are quoted for the reference design cases with maximum salt temperatures of 810°C, 20-25% reduction in inventory is possible if maximum salt temperatures can be increased to 1000°C.

/ Use of later data sets with a six batch fuelling cycle gives a breeding gain of 0.24 and a doubling time of 26 years for the oxide fuelled LMFBR; this later data has not yet been applied to the MSFR cases however.

It will be seen that the specific inventory of the molten salt system is higher than for the other two types, but if Cl-37 is invoked, the improvement in breeding gain means the MSFR can have a doubling time of about 25 years. Although this is higher than for the advanced LMFBR and the GCFR with current trends towards less frequent refuelling the breeding gains of these reactors would be lowered and the doubling times would increase.

5. Safety and Operational Aspects

It has only been possible to make a very limited appraisal of these aspects and the notes below form a preliminary assessment of the problems.

5.1 Normal Operation

5.1.1 Startup

The circuits and the salt supply will first have to be suitably preheated. The salt, either without plutonium or containing a "safe" concentration of plutonium, can be introduced into the system from the dump/storage tanks and the former fully flow tested, etc. Plutonium can then gradually be added through the on-line clean up loop, for example, until criticality at zero power and a nominal temperature is reached. Further gradual additions of plutonium will cause the power to rise and by manipulation of the secondary circuit conditions, full temperature at low power reached. Drawing heat from the secondary circuit will then cause the power to rise to the desired level. The main operational control will be by the secondary circuit.

5.1.2 Power Control

The strong negative temperature coefficient can be used for control by temperature adjustment via the secondary circuit. For very short term (i.e. spinning reserve) demands it may be necessary to incorporate some additional heat capacity in the secondary system as well as adjusting a by-pass round the steam generators. In the event of a pump fault, the system would reduce power and it may be possible to adjust back to a higher power if some plutonium addition is permissible; this would clearly not be done as a short-term measure.

5.1.3 Hotspots

The equivalent in MSFR of the classical "hotspot" of the solid fuel reactor is a region of salt with low circulation rate. A preliminary assessment for the direct cooled case suggests that within the body of the salt, the considerable turbulence would disperse hot blobs before they reach the wall, and this argument can probably be applied to the indirect cooled case. The important thing is to ensure good control of flow at the core boundary.

5.1.4 Shutdown

It would normally be desirable to use the decay heat to keep the system at temperature, and indeed if this were insufficient, to keep it "simmering" at low power.

NOT FOR PUBLICATION (COMMERCIAL)

If there was need to reach a sub-critical condition quickly, it might prove necessary to incorporate a crude shutdown system but this should not generally be invoked as the temperature coefficient should hold the system steady at low power. If necessary, the salt could be sent to the "ever-safe" dump tanks with emergency cooling to cope with a rapid drop from full power.

5.1.5 Small Leakages

- (a) Leaks between core and blanket would not have serious effects on the chemistry or materials as the salts are compatible. Further investigation would be needed as to whether it would be better to arrange pressures so that core salt leaked to the blanket to be detected by rise in Pu concentration, or to allow the (safer) leakage of blanket salt into the core and check for change of core mean temperature.
- (b) The coolant circuits will be maintained at a pressure slightly above the fuel or blanket salt thus leakage of the less active helium or lead coolant into the molten salt will occur. In neither case should there be any serious interactions. Any helium in-leakage can be dealt with by the salt cleanup system which also separates the fission product gases. Traps may be required at certain points in the circuit to deal with lead leakage so that its position is determined, and the effect of remaining small quantities on parts of the core or blanket not made of molybdenum must be considered carefully, especially if nickel bearing alloys are used.
- (c) Leakage of volatile fission products can only be met by the containment, which would have to be similar to that of MSRE, with appropriate detection and leaktight barriers. It seems reasonable to argue that the pressure differentials would prevent any significant leakage of fission products through the secondary system to the steam circuit.

5.2 Fault Conditions

- 5.2.1 Pump failure will lead to a reduction in salt flow and the consequent temperature increase will reduce power: what subsequent adjustment would be needed has yet to be examined. The main questions could arise from maldistribution of flow.

NOT FOR PUBLICATION (COMMERCIAL)

- 5.2.2 Simultaneous failure of all pump drives may be perhaps best avoided by steam turbine drives. Electrically driven pumps may have advantages for inclusion in the containment and also are easier to supply for pre-testing, etc. Inertia would help pump run-down rates, or some short-term auxiliary supply might have to be provided until full dump of fuel has taken place.
- 5.2.3 Structural damage, if serious, is a further case where dumping of fuel is the ultimate protection. Failure of the core-blanket membrane leads to no chemical or compatibility problems, and blanket salt entering the core circuit will reduce reactivity. The biggest problem arises from core salt entering the blanket, and although an initial analysis suggests that temperature rise could compensate the reactivity increase involved, this needs further careful study. Moderate rates of mixing may perhaps be accommodated by salt temperature rises, and the margins above operating temperature which could be allowed on a short term basis are substantial; what the limit is to the permissible rate of mixing needs to be established. Failure of the main (blanket) vessel calls for rapid dumping both from the circuit and from the catchpots provided. It should be noted that the dump tanks have been sized to contain the contents of one secondary coolant circuit as well as all core/blanket salt. To protect the primary circuit against any possible chance of pressurisation from a major steam generator failure into the secondary system, the latter will have to be suitably protected by relief arrangements.
- 5.2.4 Major circuit failure and the subsequent fate of fission products is an important issue in a fluid fuel system. The molten salt system does not have high vapour pressures, and although some of the primary circuit pressures can reach 3.2 MN/m^2 (460 psi) due to high pumping losses, the system with lead secondary coolant is essentially a hydraulic one in the pressurised regions so there is not a lot of stored energy. Missile formation is not therefore very likely and it should be possible to demonstrate a containment which will not be breached from this cause.

In a helium cooled system the reactor vessel could be made to withstand the full helium pressure which would result from a severe rupture between the coolant and primary circuits. Thus a simultaneous double failure would be involved to cause a release of activity to the reactor containment cell.

NOT FOR PUBLICATION (COMMERCIAL)

The cell itself is small and can economically be made in the form of a prestressed vessel to withstand missile damage and to act as a third barrier to fission product release. A final low pressure building containment would prevent release to atmosphere due to small leaks from the earlier containment stages.

Furthermore there is a continual removal of gaseous and other volatile fission products from the salts during operation which will remove a number of the more obnoxious species. Many of the remainder will stay with the salt, which can be withdrawn to the dump tanks. There should not be anything corresponding to the molten fuel accident of the sodium cooled and other solid fuel systems. The major design problem will be to ensure that (i) any salt escaping into the containment cannot fall into regions where a critical mass could form, (ii) any primary circuit failure cannot lead to critical masses forming within the circuit or other associated ones such as blanket and coolant circuits. These problems will need to be studied in the next assessment phase.

- 5.2.5 Emergency cooling takes a different meaning in an MSFR. The fuel can be dumped to prepared tanks and the removal of heat from these dump tanks can be by methods unconstrained by other requirements as in solid fuel systems. The method proposed follows the ORNL idea of natural circulation of the salt through coolers in which the heat is rejected to air drawn past by natural draught towers. Multiple systems would give a high degree of integrity and it seems possible that judicious use of heat capacity would enable it to be claimed that a forced draught system could be brought into play to give a more compact and cheaper layout.

6. Engineering Design Philosophy

The major aspects to be considered in the overall design and selection of parameters for a molten salt fast reactor are discussed below; greater detail is given in the later sections.

6.1 Choice of Materials

The most promising materials suitable for use with molten salts and possible coolants are listed in Table 6.1 and discussed in more detail in Section 8. The temperature limits quoted are based on strength considerations, as corrosion tests have not necessarily been carried out at these temperatures although lower temperature results show promise.

NOT FOR PUBLICATION (COMMERCIAL)

The effect of fission products must be considered and investigated before a final choice is made.

Fluid in contact with the material	Approximate temperature limit °C	Possible Materials
Molten chloride salt	600 700 1000-1200 (?)	Stainless steel Hastelloy N Molybdenum or TZM
Lead		
Superheated steam	500 1000(?)	Fecralloy or Croloy Molybdenum
Lower temperature steam and water	550	Stainless steel or high nickel alloys
Helium	450	Iron alloys
	900-1000 1000	Nickel alloys Molybdenum or TZM(?)

In view of its strength at high temperatures, good irradiation resistance and high thermal conductivity, molybdenum or its alloys are promising materials for all high temperature components in contact with fuel and blanket salt including the core/blanket membrane, intermediate heat exchanger tubing, duct and vessel linings. Development work on the fabrication of light molybdenum sections including welding and heat treatment will be required and is already proceeding for other applications. The high specific cost of molybdenum is acceptable as long as the heavier outer vessel and ducts, etc, are run at lower temperatures in order to allow the use of more easily fabricated and cheaper materials.

The use of molybdenum, or its alloys such as TZM*, leads to the possibility of high maximum fuel salt temperatures (above 1000°C) which will assist in reducing the fuel salt inventory and allow the possibility of gas turbine cycles and/or process heat applications using helium as an intermediate and final coolant.

The choice of materials for the remainder of the intermediate circuit of an indirectly cooled design will depend on the choice of coolant and power cycle. As the amounts of materials involved are greater than those in the primary circuit the choice is more cost sensitive and except for the high temperature helium case mentioned there is incentive to run at lower temperatures allowing cheaper materials to be used.

* Titanium, zirconium alloy of molybdenum.

NOT FOR PUBLICATION (COMMERCIAL)

In this case, however, a balance between cost, corrosion, thermal stress and avoidance of salt freezing on the intermediated heat exchanger tubes must be preserved, the latter of which can be restrictive if liquid metal intermediate coolant is employed.

With a direct lead cooled design materials must be compatible with salt, lead and steam necessitating duplex materials at least in the steam generators.

6.2 Fuel Inventory

It is important to reduce the fuel salt inventory in order to reduce fuel costs, especially in the case of high plutonium values, and also to increase the rate of installation of plant for a given plutonium supply.

In the directly cooled scheme a considerable core volume is predicted as necessary to allow time for coarse separation of the fuel salt from the lead. Furthermore external separators, involving considerable inventory in themselves, would be required to prevent any salt, carried over with the lead, freezing on the steam generator surfaces and also to reduce the inventory of such salt in the external circuits. As the net lead flow to the boilers is about 10^6 cubic metres per day the quantities of salt in the lead passing to the boilers must be no greater than a few parts per million, or alternatively, very frequent melting off would be required. The cycling times would be impractically short for typical cyclone separator performance of between 0.1 and 1% separation.

In view of these apparent limitations the directly cooled design is no longer preferred. The features of such a design as it evolved during the early study are given in Appendix I for the record. Performance parameters are given under the heading of Design 4, see Section 11.

In the indirect system employing external heat exchangers (IHx) the two basic choices are (a) an intermediate coolant which passes heat to steam generators or (b) a gaseous intermediate coolant (helium) passing direct to gas turbines.

With an indirectly cooled version there is no significant limitation of thermal rating that can be achieved in the core, but a lower limit in core size is imposed if the external/internal inventory is not to be too great for nuclear stability and room is to be provided for connecting duct work.

Temperature limitations necessitate a certain fuel salt flow rate to the intermediate heat exchangers and although the inventory connected with the heat exchangers themselves can be reasonably low that in the ductwork predominates in a practical design. Considerable thought has been given to various ways of reducing duct length but unconventional methods tend to be less reliable or less easily maintained.

NOT FOR PUBLICATION (COMMERCIAL)

Duct cross sectional areas can be reduced by employing high velocities but vibration effects may be limiting. A balance between the cost of pumping power and fuel inventory must also be achieved. Choice of intermediate coolant is clearly a further factor as it influences the heat exchanger arrangement and temperature conditions. This is discussed in the following section.

A more fundamental way of reducing external inventory is by increasing the temperature rise of the fuel salt flowing through the core in order to reduce volumetric flow rates. The core inlet temperature must be sufficiently above the fuel salt freezing point to prevent excessive salt freezing on the cool end of the heat exchangers; therefore as high an outlet temperature as possible is desirable within the limits imposed by materials and thermal stress considerations.

6.3 Choice of Intermediate Coolant

Liquid coolants are considered only in conjunction with a steam power plant as it seems doubtful whether anything is to be gained by transferring the heat in a further set of heat exchangers to drive gas turbines.

Of the liquid metals sodium suffers from the disadvantage that fuel leakage into the coolant would cause an exothermic reaction and removal by processing would be difficult, so that even if it is assumed that the general problems of sodium technology will be overcome by LMFBR development, there is a basic objection.

Lead therefore appears to be more attractive chemically as it does not react significantly with either salt or steam and should not enlarge any leaks. Pumped by-pass systems are required on the lead intermediate circuits to give the required operating temperatures to avoid high thermal stresses in the steam generators due to high temperature differences, and to avoid salt freezing on the intermediate heat exchanger tubing; although it may be arguable that a thin layer of frozen salt could be allowed (see 7.2).

A molten salt such as $\text{NaF}:\text{NaBF}_4$ or Na Al Cl_4 is best on engineering and thermal hydraulic considerations as it gives well matched heat transfer with low fuel inventory and reduces freezing and thermal stress problems. Considerable experience of pumping and general use of molten salts has been accumulated. However leakage of steam into the coolant salt could produce locally high corrosion, and processing difficulties would arise if the coolant leaked into the fuel salt. It was therefore concluding that molten salts probably were not a satisfactory choice.

NOT FOR PUBLICATION (COMMERCIAL)

Although the cost of lead is high this is not an overwhelming objection to its use and lead has been chosen as the preferred liquid coolant. Development work on pumps and components as well as on its corrosive effects will be required and high strength construction will be needed due to the inertia effects resulting from the high density. Special measures will be required to prevent lead freezing at low power conditions and at start-up. Low alloy steels can be used for the cooler parts of the lead circuit but other measures may be required where temperatures are in the region of 500°C or over. Duplex tubing will be needed in the superheater as nickel bearing alloys are attacked by lead.

Of the gaseous coolants CO₂ and other oxidising gases will probably react with the fuel salt, in case of leakage, to form UO₂ which could overload the oxide removal section of the salt clean-up plant. Helium is therefore preferred on grounds of compatibility with fuel salt, for its high temperature applications, for reduction in thermal stress problems, and as considerable knowledge and experience will be available by the time molten salt fast reactors are built. It is also likely to be well suited for use with the molybdenum heat exchanger tubing although this is not yet fully endorsed. It will require a higher fuel salt inventory than for liquid coolants for the same temperature conditions, and require consideration of the safety issues arising from a pressurised coolant.

6.4 Choice of Power Plant

The designs of MSFR considered in this report have been linked to a conventional subcritical steam cycle to give a cost comparison of the lead cooled case with a sodium cooled fast reactor employing similar steam conditions. A supercritical cycle could be employed or, to make fuller use of the inherent high temperatures, process heat or topping cycle applications could be considered.

Either lead or helium intermediate coolants may be used with an HTR plant.

The use of a helium gas turbine cycle is attractive as it does make use of the high temperature potential of the molten salt system as well as being suitable for dry cooling heat rejection where the situation demands. It also forms an engineering entity as the gas turbine plant is similar to that of the reactor in terms of size and scantlings; the working pressures are lower than for a steam plant and the possibility of prefabrication with low installation times could lead to savings on construction and interest charges. Plant costs may be reduced by the elimination of the further heat exchangers required for steam generation although the extent of cost savings will depend on the overall efficiency selected for a gas turbine cycle.

NOT FOR PUBLICATION (COMMERCIAL)

If a rapid MSFR system development is required to meet expanding electricity demands, plutonium inventory must be kept low requiring a high efficiency cycle with fairly costly recuperators, but if rapid expansion of the system is not so important, and especially if plutonium is of low value, the cost of the recuperators could be reduced or eliminated.

Only one preliminary design of core and intermediate heat exchangers for helium cooling is given in this report. Alternative helium cooled designs matched to the power plant requirements and using concrete pressure vessels will be given in subsequent reports.

6.5 Blanket Inventory and Cooling

There is not so much need to reduce the blanket inventory as for the core fuel as the U-238 value is low, however if C1-37 is used to enhance breeding its cost is such that excessive blanket volume should be avoided. Pumping and cooling will be similar to that of the core with arrangements so that the blanket power output varying from 2 to 15% over the fuel cycle can be accommodated as a contribution to the total intermediate coolant flow.

6.6 Reliability and Maintenance

There are no intricate mechanical features in a molten salt reactor, thus the basic reliability of the system should be high and be similar to that of chemical or hydraulic plant. To achieve this state parameters and materials must be chosen to be within the limits endorsed by long term testing. This particularly applies to the effects of corrosion, thermal expansion, and high salt velocity. If these features are thoroughly understood the reliability of pumps, heat exchangers and containing materials can be ensured. As there are no complex refueling mechanisms and no close tolerances as in solid fuelled reactors and no mechanical control devices in the core or blanket a number of major factors affecting reliability are eliminated.

It is important to show that similar principles of simplicity, reliability and maintenance are applicable to the auxiliary plant required for clean-up and reprocessing and this is an essential part of any further study programme.

The ORNL Molten Salt Reactor Experiment has demonstrated that maintenance on an active fluid fuel system can be carried out without undue difficulty, although it is important to design in features to assist in this respect. Such features should include ease of pump replacement and means of heat exchanger repair, by replacement or by in situ repair or plugging of tubes. As an example, Design 2 illustrates a U-tube heat exchanger design giving freedom of expansion of major items and with facility for plugging any leaking tubes from the less active coolant circuit side.

NOT FOR PUBLICATION (COMMERCIAL)

These features are obtained at the cost of some extra fuel inventory.

6.7 Engineering Development

The most important development work required is that on the corrosion aspects of the fuel and blanket molten salts with the complete spectrum of fission products and likely impurities. It is important to determine the upper limit of temperature for long term operation under the appropriate neutron flux levels. The principal areas of component development appear to be:-

- (a) Work on pumps will be required to develop high temperature pumps of considerable power for fuel and blanket salt with geometry to suit the low inventory requirements, and to deal with the high density of the lead coolant if selected.

There is experience in low power molten salt pumps and more general experience of similar problems of sealing, bearings and high heads in liquid metal and HP water pumps but considerable testing will be required under the proposed operating conditions.

- (b) On heat exchangers with small bore thin-walled tubes closely pitched in a similar manner to fuel clusters which will require development and testing to resist the thermal and vibrational strains over a long working life and to be suitable for manufacture from molybdenum.
- (c) For the core and blanket hydraulic model work is needed (i) to prove that there is good flow distribution with no large stagnant zones and (ii) to determine the effects of velocity and density on stresses and vibrational effects to establish designs with adequate limits. Fabrication and expansion considerations will also need study.
- (d) Full scale and fully instrumented work with hot molten salt will eventually be required as proving tests in all these areas of development.
- (e) The fate of the fission products will require special attention as the order of magnitude of non-gaseous and non-volatile products which do not form soluble chlorides is about 0.8 tonne per year; this could be serious if uneven deposition occurs. The experience of MSRE may give some indications of distribution although the power was low in comparison with the MSFR proposals.

7. Outline System Designs and Auxiliary Plant

7.1 General Aspects

A summary of the features of four initial designs as illustrated in Figures 1 to 4 is given in Table 7.1. Figures 1a and 1b (Design 1) show typical arrangements of reactor and heat exchangers for indirect lead cooling for minimum fuel inventory, the latter figures showing the larger heat exchangers needed if the lower and probably more realistic salt conductivity value is used. Figure 2 (Design 2) shows an indirect lead cooled design layed out for freedom of expansion of the major components, for cooler outer regions of both core and blanket and with U tube heat exchangers in which tubes could be plugged from the less active lead cooled side. Figure 3 (Design 3) illustrates the dominance of the heat exchangers on the layout of a helium cooled indirect design for a maximum salt temperature of 850°C. Figure 4 (Design 4) is a tentative layout of a direct lead cooled design using concepts which emerged as the result of a theoretical study of direct cooling with only limited and very small scale experimental backing.

Flow diagrams are given in Figures 9, 10 and 11 and detailed parameters in Section 11. Details of the directly cooled design are given in Appendix I and preliminary ideas for an internally cooled MSFR are covered in Appendix II.

As compatibility problems in case of leakage have led to the rejection of molten salt as an intermediate coolant no details are given in the main text, although parameters have been calculated.

Figures 5, 6 and 7 showing the overall plant layout have been based on Design 1, but the other designs employing a steam cycle will be similar.

All designs employ a multiplicity of cooling circuits to reduce the effect of pump failure. In case of circuit rupture the whole core and blanket may be dumped into tanks provided with natural circulation emergency cooling. A valuable feature of the MSFR is that the fuel may be drained and the whole reactor vessel or individual heat exchanger units replaced. No item of plant is more than 6.5 m diameter and shop fabrication should be possible. The compact layout is indicated in the figures and an overall size comparison with a typical LMFBR and the lower powered MSBR is shown on Figure 8.

NOT FOR PUBLICATION (COMMERCIAL)

TABLE 7.1 - 2500 MW(e) NET MSFR: SUMMARY OF FEATURES

Type	Indirectly Cooled			Directly Cooled
Coolant	Lead	Lead	Helium	Lead Curtain
Design	1°	2 ^f	3 ^f	4°
Fuel salt temp in/out °C	650/810	660/810	670/970	800 Max
Coolant temp in/out °C	480/600	570/670	400/850	370/630
Outer Blanket Temp °C	650	650	650	650
Core Shape and Size	"Spherical" 3.2m dia	"Spherical" 3.2m dia	"Spherical" 3.2m dia	Vertical cylindrical 3.2m dia x 5m high
Flow in core	Downwards	Upwards in centre, cool return down in outer annular region	Upwards in centre, cool return down in outer annular region	Poloidal with lead curtain
Heat exchangers	8. Vertical Tube in shell, salt flow thro' tubes. Counterflow. Tube bundle removable.	8. U tubes in annulus surrounding pump salt on shell side, cool return in outermost annulus - counterflow, pluggable.	10. J tube in shell. Helium on shell side. Counter flow. Removable complete.	-
Fuel Salt Pumps	8 centrifugal	8 semi-axial two stage	10 semi-axial two stage	Lead jet pump vanes in corporate into top of core inducing poloidal salt flow
Pump Operating Temperature °C	650	810	670	-
Pumping Power (all pumps)				
(a) Core salt MW	48°	94	55	-
(b) Blanket salt MW	23°	21	38	23
(c) Coolant core/ blanket MW	78/12°	84/16	134/29 (JHX & pipework only)	120-240/12
Total MW	161°	215	256	160-280
Fuel salt volumes core/ext m ³	17/21.5°	16/28	16/22	37/15-18
Total fuel inventory Pu239 equivalent Te	9.5	10.8	9.4	9.2
Breeding gain (C137)	0.29	0.3	0.3	0.35
Linear Doubling Time Years	25	28	24	21
Other features	Vessel runs at upper blanket temperature in places. Bellows required.	Pumps run hot. Outer vessels run at cool salt return temperature. Freedom for expansion allowed, generally.	Bellows required.	

Notes: ° Assuming highest (ionised) value of thermal conductivity of fuel salt and 70:30 salt MP. 557°C, see section 7.3
^f Assuming mean of ionised and un-ionised theoretical values of thermal conductivity and 60:40 salt MP. 577°C.
^o Normalised to 6000 MW(th) maximum core rating and 900 MW(th) maximum blanket rating from detailed parameters quoted for 5700 MW(th) and 300 MW(th) respectively.

NOT FOR PUBLICATION (COMMERCIAL)

It is seen that the overall building and civil work are reduced for MSFR compared with a LMFBR largely due to the absence of fuel handling facilities. If reprocessing by an in-line pyrochemical process proves practicable and economic the space required to house the plant and attendant control and maintenance areas can be incorporated in the building without increasing its size significantly. A saving in space could be made if high pressure storage of fission gases is feasible.

With the available effort it was necessary to concentrate the design work on the reactor vessel and primary heat removal systems, nominal values only being obtained for the remaining systems associated with the reactor, e.g. steam generators, dump system with emergency cooling, off-gas system with delay beds, fission product removal and clean up. It has become apparent that these latter items have a significant influence on the plant and greater attention would in future have to be given to the principles involved and the detailed design in order to establish quantitative costs.

7.2 The Indirectly Cooled Concept

The reference lead cooled designs have been based on a total reactor output of 6000 MW(thermal) over 98% of which is initially produced in the core, but allowing for what was considered to be an upper limit of 15% power to be produced in the blanket at the end of the fuel cycle. The core is roughly spherical of 3.2m diameter and 16 to 17 m³ volume. Small variations of core size would have little effect on costs or external fuel inventory. An outer blanket zone of 1m nominal thickness is also cooled by external heat exchangers of similar type to those cooling the core salt. Cool return flow is arranged in the blanket to keep the reactor vessel below 650°C and allow nickel alloys or stainless steel to be used for the outer vessel. This principle of keeping down temperatures in outer vessels or pipework is followed as much as possible in the layout. The core is separated from the blanket by a single, or double, thin molybdenum membrane of 1cm total thickness which is suitably stiffened to withstand the static heads and differential pumping pressures. Pump inlet pressure is only slightly above atmospheric, thus the outer vessel is only required to contain pressure due to pumping at between 2.6 and 3.6 MN/m² (380 and 520 psi) depending upon the design. Pumping pressures between core and blanket must be approximately balanced.

The vessel and heat exchangers would be mounted in a hot box for pre-heating above the fuel/blanket salt melting point (580°C). Lower temperature hot boxes or locally applied heating will surround the secondary piping and steam generators in the lead cooled case (lead melting point 327°C).

NOT FOR PUBLICATION (COMMERCIAL)

The general reactor arrangement is governed by (a) the need for a compact system to primarily reduce the fuel and secondarily the blanket inventory costs; (b) the maximum temperature allowable in the core region from corrosion and thermal stress considerations in the core (or blanket) and intermediate heat exchangers or steam generators, and (c) the minimum salt temperature on the heat exchanger surfaces if freezing is to be avoided.

Maximum fuel temperatures have been limited in the reference designs to the lowest values judged to give an acceptable compromise for the above conditions for early MSFRs. This is 810°C for the lead cooled designs and 970°C for helium cooled systems. Corrosion tests at higher temperatures, i.e. above 1000°C are required to indicate the potential of higher limits which would allow lower fuel inventory and pumping costs. Steady state thermal stresses with the temperature differentials applying in the heat exchanger tubing and boundaries between the hot salt outlet and cool return or at the core blanket membrane are acceptable, but thermal sleeves may be required at discontinuities. Consideration has yet to be given to the effects of sudden change of load on thermal stressing, although preliminary control studies indicate that the change of the fuel salt mean temperature is modest. High salt flow rates are required to give values of the salt return temperature which, in allowing for the boundary layer temperature drop gives wall temperatures high enough to prevent freezing or plating out of fission products on the IHX surfaces. Similarly, the lowest lead temperature must be kept high due to the good heat transfer on the lead side. This in turn necessitates high pumping losses in the intermediate circuit. If freezing can be allowed without causing excessive pressure drop (due to a "slushy" mixture?) or without causing excessive plating out of fission products then flow rates could be considerably reduced with consequent savings in inventory and pumping power. The freezing problem is not so pronounced with helium cooling as the IHX tubing surface runs at a high temperature due to the lower heat transfer on the helium side.

To reduce the pumping powers and the temperature differences between the lead and the water in the evaporators, which could cause high thermal stresses, it is necessary to pass lower lead flows through the steam generators and mix with the flow from the IHX to give more suitable temperatures as shown on the Flow diagram, Figure 9. The parameter list shows the quantities.

7.3 Design Variations of the Indirectly Cooled Concept

A summary of the main distinguishing features of the various designs is given in Table 7.1.

NOT FOR PUBLICATION (COMMERCIAL)

As measurement of the salt thermal conductivity is not yet complete, Designs 2 and 3 are based on what is considered to be a realistic value of $0.5 \text{ w.m}^{-1} \text{ K}^{-1}$ which is the mean of the ionised and un-ionised values. Design 1 used the original, more optimistic value of $2.0 \text{ w.m}^{-1} \text{ K}^{-1}$.

In all designs the pumps are arranged with vertical shafts as successfully tested at ORNL.

Further work is continuing on the helium cooled variations which will show an improved layout and tackle the problem of a high pressure intermediate coolant circuit.

It should be noted that in helium cooled designs the high pressure will cause any small leaks to be from the helium into the salt, thus preventing the spread of activity. The limiting leakage will depend on the capacity of the salt off-gas clean-up plant.

In order to give a true comparison of the lead and helium cooled designs, it will be necessary to carry out a reasonably accurate comparison of overall costs, including the cost of introducing a new lead coolant technology and the costs of safeguards against helium circuit rupture.

7.4 Special Auxiliary Plant

It should be noted that only a small amount of engineering design work has been done on the auxiliary plant, most of which is similar to that proposed by ORNL for the MSBR⁽²⁾ except where the chemical composition of the chloride salt in MSFR causes differences. Nominal parameters are given in Section 8, the Flow diagrams, Figures 9 and 10, and building layout, Figures 6 and 7, show the disposition of the main items.

7.5 Filling, Draining and Dump Systems

The arrangements are shown in outline on the flow diagram, Figure 9. Two tanks are mounted below the reactor vessel serving as filling and drain tanks respectively. They are each sized to contain the whole salt inventory associated either with the core or the blanket plus the lead inventory contained in one of the respective coolant circuits which, being individual loops, can be regarded as independent. The two tanks also serve as dump tanks for quick dumping of the core and/or blanket as described in Section 7.6, or for receiving salt which leaks from the reactor vessel via the catchpot below the reactor. A third tank of equal volume to one of the two tanks described is provided as a standby and to serve as a delay tank for salt removal for processing. If separate processing of core and blanket is required this tank will be divided into two. The emergency cooling system would also be used to remove the decay heat on normal draining.

NOT FOR PUBLICATION (COMMERCIAL)

Smaller delay tanks are provided for batch entry and discharge to give a minimum delay period for fuel or blanket salt passing to the processing plant. Further tanks are provided for enrichment trimming. Mechanical pumps or gas pressure can be used for salt transfer. For initial filling the fuel or blanket salt will be brought to site in solid form and heated under inert gas in small non-critical batches to run into the respective non-critical shaped tank from which it can be pumped into the reactor.

7.6 Emergency Cooling System

The system provides a reliable and completely separate means of removing heat after reactor shutdown by draining the fuel and/or blanket salt into the dump tanks. Cooling of the dump tanks is reliably achieved by natural circulation of a low melting point salt or Na-K through U-tubes, occupying most of the drain tank volume, to boiling water heat exchangers. The steam formed is condensed in air cooled condensers situated in a normal or forced draught stack. Alternatively, the heat may be transferred directly to a large pool which is allowed to boil, thus accommodating decay heat for a protracted period without make-up. Condensers or make-up water would be provided for continuous operation.

The heat removal capability of the emergency cooling system described in this report was based on decay heat removal of $2\frac{1}{2}\%$ from each tank on the assumption that all fuel salt could drain into one tank only. When the effect of remaining neutron power after complete loss of main cooling is added considerably higher heat production (up to 6% of full power) could occur in a rapid dump. Temperature transients will be studied in relation to dump times to determine a more realistic assessment of the heat removal required allowing for the heat capacity of the emergency coolant.

7.7 Salt Cleanup and Gaseous Fission Product Removal

These terms refer to the on-line treatment of fuel and blanket salt to remove oxides, to reduce UCl_4 to UCl_3 and to remove gaseous fission products. A tentative flow-sheet is shown in Figure 10.

In order to avoid build-up of gases which would affect circulation and cause pressure to build up and also to reduce the amount of gaseous fission products that may be released in the event of circuit rupture, the off-gases are continuously removed. A similar system to that proposed for MSBR by ORNL could be used. In this the gases are separated in a recirculating loop across the main fuel (and blanket) salt pumps by injecting helium bubbles to cause nucleation. The fission products removed consist mainly of xenon, krypton, tritium and small particles (fog) of noble metals.

NOT FOR PUBLICATION (COMMERCIAL)

The gases, together with those purged from the pump bowls and from the highest points of the salt circuits, are passed through a cooler with a small quantity of salt from the main pumps, to the drain tank. Due to the size of the tank there is considerable holdup and reduction in decay heat (which passes to the tank coolers). Some noble metals will probably deposit. The gases are then passed through particle traps to charcoal beds for absorption. In the MSBR system 80% of the gas flow is passed to a chemical trap, and after compression into a surge tank it drives the bubble generator and returns to the primary circuit. The remaining 20% of off-gas flow may be passed to a long delay system in which all isotopes except the 10-year Kr-85 will decay to an insignificant level. The gases are purified by removing Kr-85, stable isotopes of Kr Xe, water, etc, before returning to the primary circuit via a surge tank and compressors.

It is likely that the noble metals, except those escaping as fog, will deposit in various parts of the primary or FP removal circuits as already referred to in 6.7.

The remaining fission products, ie, 50-60% of those formed, will be dealt with in the external processing plant unless on-line treatment processes can be developed.

It would appear that the main design work required for gaseous fission product removal is in sizing the plant to cope with the absorption required in the delay beds and the heat removal requirements to avoid excessive temperature rise in the charcoal. The MSFR building layout shown provides for an outer annular ring for delay beds based on this method and sized pro rata with power to the MSBR proposals. The form of the beds can either be as in DRAGON, in which the cooling water is contained in cylindrical tanks or, as in the MSBR case, in a swimming pool type trough with low pressure steam formed above the pool and passed to condenser units.

In view of the large size of the delay bed system which dwarfs the reactor, alternative methods of storing fission product gases should be considered. There appear to be design principles which could permit the gases to be stored safely and reliably at high pressure.

In order to clean up the salt chemically, flow from the main pumps is passed through:-

- (a) an UCl₄ reduction bed formed by inserting uranium metal into the stream in sufficient quantity to satisfy the reaction - the form of uranium, whether rod or gauze or turnings must be determined;

NOT FOR PUBLICATION (COMMERCIAL)

- (b) oxide removal bed. This may take the form of a continuous process of injection of liquid Na-Al-Cl₄ and filtration or cyclone separation of the solid alumina formed. Alternatively a batch process could be used and alumina precipitated could be removed alternately from the on and off line plants.

The tentative flow rates and reaction requirements are given in the parameter list - these must be confirmed before worthwhile plant design and costing can proceed.

7.8 Processing Plant

The term "processing" refers to separation of a large proportion of the remaining fission products from the core and blanket salt, separation of the plutonium from the blanket salt, and enrichment of the core salt to replace fuel burnt up.

For present design purposes it has been assumed that processing will be by aqueous methods and will be carried out remote from the reactor, possibly at some central national site or a plant serving several reactors and no plant is described here. If the economics of on-site pyrochemical processing turn out to be more favourable than is predicted at present, the plant can easily be accommodated within the reactor building due to its small size.

It may be possible to direct the blanket salt into the core, and only process the salt taken from the core.

7.9 Remaining Plant

7.9.1 Containment

The aim will be to construct the primary and intermediate circuits to standards to give negligible leakage rates (as achieved on similar size components on the DRAGON reactor).

To deal with any leakage and to provide an inert atmosphere round the hot parts of the plant, if this is necessary, a secondary containment is formed by a low pressure leak-tight membrane around the walls, floors and ceiling of the plant cells. This membrane can also form part of the ducting for the gas circulation required to cool the concrete structure and shielding. Heat losses with insulation restricting the concrete temperature to below 70°C would be about 200 watts/m² with 40 cm of insulation. This would equate to about 3MW total heat removal by water or air cooling.

A tertiary containment can be incorporated in the main building, the volume of which must be sufficient to contain the stored energy of any gases present.

NOT FOR PUBLICATION (COMMERCIAL)

These will be confined to cover gas volumes at low to moderate pressure in the lead cooled design but for the helium cooled version a larger outer containment volume and/or intermediate prestressed concrete containment may be required.

7.9.2 Preheating

Preheating to about 600°C for the salt circuits and 330°C for lead will be required. In some cases it will be more economic and convenient to heat whole spaces such as the reactor vault and processing plant, but where longer lengths of pipework are involved as in the lead pipes to the steam generators, trace heating would be preferred. No particular problems have been encountered with preheating on the ORNL MSRE.

7.9.3 Shielding

No calculations have been made. A nominal thickness of 3 metres has been allowed on the drawings at the critical positions.

7.9.4 Pumps

The single stage centrifugal salt pumps shown in Design 1 can be similar in principle to those successfully tested in the MSRE and in loops up to 16,000 hours running at 650°C. For the two stage semi-axial design basic development work may be required; in both cases development and testing will be required to successfully increase sizes to the 5-12 MW range.

There is no direct experience of high power, continuously running lead pumps. The design principles would probably follow the sodium pump design developed for sodium fast reactors but with higher power and strength requirements.

7.9.5 Steam Plant

Standard steam conditions of 16.3 MN/m² (2350 psig) at 838K (1050°F) with reheat to 811K (1000°F) are proposed using once-through boilers. For costing and layout purposes a once-through U tube design or evaporator, superheater and reheater has been used. Units are duplicated in each of the main circuits to reduce the tube plate size.

Two 1350 MW(e) gross output T/A sets are shown, although a greater number of lower power sets could be equally conveniently situated. Station load would be about 200 MW including approximately 160 MW pumping power, giving a net efficiency of 41.7%.

8. Materials

The problems of selecting structural materials for the MSFR family of reactors are difficult but not insuperable. Even at this early stage it is possible to make recommendations which appear feasible and the problem areas which have been identified are probably not intractable. Each design will be considered separately.

a. Design 1. (Indirectly cooled with lead - first version)

The choice of materials for the core components, in contact with fuel salt and blanket salt is limited to high nickel alloys or refractory metals. In practical terms the choice is probably between Hastelloy-N (or more advanced developments of that alloy) and molybdenum alloys (particularly TZM). The superior high temperature strength of molybdenum alloys and their greater resistance to radiation embrittlement at high temperature make them the more attractive for the higher temperature components (eg the core/blanket membrane). Hastelloy-N is a possibility for the less severe conditions of the reactor vessel and the salt ducts returning from the heat exchanger. If molybdenum were used for these components it would presumably have to take the form of duplex materials, eg a stainless steel vessel internally clad with molybdenum; if massive molybdenum were used steps would have to be taken to prevent its external oxidation, for example by containing the reactor vessel and other sensitive components in a hot box purged with an inert or slightly reducing atmosphere. There is some incentive for using molybdenum alloys for all the components, including the pumps, which come in contact with the salt. Firstly, having decided to use molybdenum for the core/blanket membrane, a change to another material elsewhere in the salt circuit would introduce the possibility (difficult to assess at present) of dissimilar metal effects. Secondly, nickel alloys resist molten lead very poorly compared with molybdenum and hence would probably be subject to attack when the lead leaked into the salt.

The heat exchanger tubes are subjected to both the fuel salt and molten lead and hence would preferably be fabricated of molybdenum alloys. Such alloys are normally highly resistant to lead but there is conflicting evidence about the effects of small amounts of oxygen in the lead, as would result from a steam generator leakage. For this reason it may be advisable to minimise the oxygen level in the lead by means of a getter (magnesium or calcium) dissolved in the lead. Alternatively the molybdenum may have to be clad externally with an alloy resistant to "oxygenated" lead. A ferritic steel containing aluminium (Fecraloy) which should form a protective alumina film under these conditions is a candidate cladding material. The possibility of making the heat exchanger tubes of Hastelloy-N has only slight attractions and in any case this material would have to be clad externally either with Fecraloy or molybdenum to make it resistant to lead.

NOT FOR PUBLICATION (COMMERCIAL)

The ducts carrying the lead to and from the steam generators and also the steam generator shells could probably be molybdenum (protected from external oxidation either by a stainless steel cladding or by means of an inert atmosphere) or less probably of FeCrAlloy (externally clad with stainless steel for strength considerations).

The steam generator tubes pose another problem associated with the probable steam leaks into the lead, because it is likely that the "lead side" of the tubes will locally be in contact with steam in quantities much too high to be removed by an possible getter. Hence it may be difficult at present to recommend molybdenum for use in the steam generator tubes. An alternative, as yet untried, would be to use FeCrAlloy in the hope that it is resistant both to steam and to oxygenated lead. Its poor high temperature strength could be overcome by using it in the form of a FeCrAlloy-stainless steel duplex and the selection of stainless steels to resist the water/steam side of the steam generator should be conventional.

b. Design 2. (Indirectly cooled with lead - second version).

Considerations of materials selection are very similar to those of Design 1. The use of cool salt from the heat exchanger to reduce the temperature of the core/blanket membrane and of the reactor vessel may permit the adoption of Hastelloy-N for these components. However other considerations may still demand the use of molybdenum, in which case the lower temperature may actually be a disadvantage in that radiation embrittlement of molybdenum may be more severe.

Another major difference between Designs 1 and 2 is the higher salt pump temperature in the latter and this may increase material selection and engineering problems.

c. Design 3 (Helium cooled).

Many of the features of the reactor itself are similar to those of Design 2 except that the temperatures are significantly higher (the core temperature is 970°C instead of 810°C). This would certainly necessitate the use of molybdenum alloys, especially on mechanical grounds, and although there is no special reason to doubt their corrosion resistance at this temperature, any supporting evidence is completely lacking. Design 3 shows one significant relaxation of conditions compared with Design 2, viz the reduction of the salt pump operating temperature from 800°C to 670°C , and this will doubtless ease the engineering and the selection of materials.

The adoption of helium cooling would probably go even further to ease the materials selection problems but it should be made clear that much less effort has been devoted to materials selection for this design than for the lead cooled designs. Hence there could easily be problem areas

NOT FOR PUBLICATION (COMMERCIAL)

as yet unidentified but equally challenging as found with the lead cooled systems.

The assumption is made that a helium cooled system could make extensive use of the work already done with respect to HTRs, and specifically in relation to gas-turbine versions, and that the MSFR version could ride on the future HTR programme. In connection with HTRs it is well recognised that, in practice, helium is not an inert coolant since traces of air, moisture and other oxidising gases can cause corrosion and traces of carbonaceous gas can bring about carburisation of candidate structural materials. A great deal of work still has to be carried out before a detailed specification of materials could be made. However it does seem likely that (a) it will be possible to specify the impurity levels acceptable in the helium, methods of controlling them and what intentional additions, if any, should be made, for example, to render the helium reducing, and (b) selected nickel alloys could be used for the turbines and other circuit components. This would restrict the need for molybdenum in the coolant circuit to heat exchanger tubes and similar applications.

d. Design 4 (Directly cooled with lead)

The directly cooled system is rather less attractive from the point of view of materials selection than the indirectly cooled system for several reasons:

1. There are more situations where components have to resist a number of aggressive corrodents simultaneously (eg lead, fuel salt and air); hence Hastelloy N is less attractive for core components which may come in contact with entrained lead.
2. The lead will contain fission products, transmutation products, and, very likely, entrained salt.
3. There is less scope for adjusting the detailed composition of the lead without the constraints imposed by interactions with the fuel salt.

Although it does not seem that any of these aspects impose insuperable problems they do increase the difficulties of specifying materials for the system. Nevertheless it still seems probable that suitable materials can be selected from the range already considered, eg, molybdenum, Hastelloy-N, stainless steel and Fecraloy.

9. Costs

9.1 Capital Costs

The indirect lead cooled MSFR has been compared with a pool version of a sodium-cooled fast breeder system of

NOT FOR PUBLICATION (COMMERCIAL)

circa 1990, as being the reactor type nearest in general form to the MSFR. The difficulties of doing this even in broad terms will be recognised but it is possible to identify certain areas where the MSFR has potential for cost savings:-

- (a) the MSFR system avoids elaborate control systems and complex fuel handling equipment. There should therefore be gains on compactness and simplicity grounds, but there will be extra costs for certain ancillary systems which must be allowed for.
- (b) savings on contractors' and customers' costs should accrue because the size of the components indicates that shop fabrication is possible in nearly all cases; further, simplified erection, testing and commissioning procedures should be possible with a plant of chemical type. By the same arguments there should be reductions in construction time with consequent savings in interest and overhead charges.

The net result of this semi-quantitative comparison is an estimated saving on capital cost relative to a 1990 LMFBR of £12-20/kW(e)*, 1972 values.

Although it may be argued that by the time MSFRs could be in operation LMFBRs would have advanced beyond the 1990 version, it should be noted that the comparison referred to above does not credit the MSFR with two areas of possible further potential:-

- (a) if full advantage could be taken of the higher temperature potential of the system (see Section 7.2) a possibly optimistic but not unrealistic estimate of further savings on plant costs leads to forecasts of gains of about £25/kW, for the lead secondary coolant/steam plant system.
- (b) should the further studies of helium as secondary coolant show promise of meeting the safety arguments, the possible temperatures permit consideration of gas-turbines, which with a layout integrated in a pre-stressed concrete pressure container vessel, is clearly a line worth pursuing for further savings.

9.2 Fuel Costs

For comparison with other system fuel costs, the costing is based on 1.1.72 prices, 25 years operation, 75% load factor. The values given below have been assessed for the Indirect System (Design 1) using off-site aqueous solvent extraction methods for heavy metal processing and removal of residual fission products. An on-line plant is assumed for removal of volatile fission products and salt clean-up.
* £/kW quoted as present worth.

NOT FOR PUBLICATION (COMMERCIAL)

The effect of this continuous partial removal of fission products is discussed further below. The cost figures allow for inventories both in the reactor and in the reprocessing cycle, where a hold up time of six months is taken, composed of three months cooling-off delay period and three months processing and transport time. In addition, an allowance of one month's stock of fresh fuel at the reactor site is made. Estimates were made also of the cost of separating Cl-37 and its effect on reprocessing procedures so as to be able to make a comparison with the natural chlorine case which would allow inter alia for the inventory aspects introduced by the higher-valued fuel salt containing Cl-37.

As has been mentioned earlier, the on-line pyrochemical process was examined in the hope that it would contribute to reduced inventory and thereby effect improvements over the aqueous processing route, but while it appeared technically feasible, the initial estimates were discouraging due to indications of high costs arising from batch processing of small "non-critical" quantities and the remote operation and maintenance involved. This is an area which requires further study.

It is possible that the combination of an on-line salt clean-up plant with plate-out of noble metals will result in an effect equivalent to 50% of the fission products being removed from the core region, and a survey analysis was carried out assuming this value to assess the desirable rates of throughput for the external reprocessing plant. The rate has been expressed as a cycle time, ie, the time to process a volume of salt equal to the primary and blanket system inventories. The survey indicated that system inventory and doubling time are relatively insensitive to cycle time even up to values of 15 years. However, for cycle times of over 10 years the heat generated in the blanket exceeds 10% of the total heat output and it is judged that excessive capital cost would then be involved in blanket heat removal plant which would be running below capacity for over one-third of the reactor life. It was therefore decided to use an equivalent cycle time of 7.5 years as a compromise. This figure is a judgment, and further study is desirable to derive a better understanding of the effects of the various parameters.

The investigation showed that while the use of Cl-37 gave a notable improvement in nuclear performance in reducing doubling time (see Section 4), the additional inventory charges resulting from the increased salt costs made the fuel costs higher for the Cl-37 case than for natural chlorine salt.

Taking plutonium as having zero value so as to bring out the "fabrication and reprocessing" aspects showed that compared with the oxide fuelled LMFBR of Table 4.1/ the potential savings for the MSFR, expressed as £/kW discounted present worth, were £16/kW for the Cl-37 case and

NOT FOR PUBLICATION (COMMERCIAL)

£20/kW for the natural chlorine case. It was said in the Introduction that the one of the hoped-for gains would be a considerable saving on fuel "fabrication and reprocessing" charges and these figures demonstrate that this is possible. But if plutonium is given a typical value of £5/gm, inventory effects reduce the potential gains to £7/kW with Cl-37 and £8/kW with natural chlorine.

If however the maximum fuel salt temperatures can be increased from the 800°C of the reference lead-cooled case to 920°C, the inventory requirements reduce by 25% which with plutonium at £5/gm gives a further reduction of about £5/kW for both Cl-37 and natural chlorine MSFRs. The inventory then approaches that for the oxide-fuelled LMFBR and the natural chlorine version doubling time would fall to a value similar to that of the LMFBR.

9.3 Overall Generating Costs

The indications from the above estimates are that the total generating costs for the reference case lead-cooled MSFR (assuming similar operating costs) would be in the range £20-30/kW less than for a 1990 oxide fuelled LMFBR with plutonium at £5/gm, on a discounted present worth basis and referred to 1.1.72 prices. With plutonium at zero value this margin increases by about £8/kW. Alternatively if the higher temperature MSFR version can be established, the gain with plutonium at £5/gm would be increased by £10/kW or more. It is of interest to note that on the present analysis, the gains claimed accrue somewhat more from capital cost savings than from fuel cost savings and this puts emphasis on the importance of further investigation of plant design, and maintenance problems, and the associated safety issues, to ascertain better the validity of the claim. It should be noted also that the fuel costs have been derived on the basis of aqueous processing for heavy metal where the route is reasonably well established, and that it has only been necessary to invoke an on-line high temperature process for the salt clean-up.

Although therefore it can be expected that there may be improvements in LMFBRs compared with the 1990 version, the MSFR appears to have potential justifying its further study, bearing in mind also that no claim has been made for benefits arising from avoiding the losses in operating time arising from shutdowns for refuelling in the LMFBR.

10. Conclusions

The conclusions which can be derived from the studies summarised in this report are:-

- (i) of the alternative forms of MSFR examined, the indirect-cooled versions (see Figures 1b or 2) appear to offer most potential for further investigation. There are however uncertainties in a number of physical properties (notably thermal conductivity) which reflect

NOT FOR PUBLICATION (COMMERCIAL)

noticeably on choice of design conditions, and these, coupled with some uncertainties on nuclear data, make it difficult to achieve any substantial degree of optimisation in design at this stage.. Choice of secondary coolant is an important feature, and of the liquids, lead appears to be the most suitable taking into account compatibility with the fuel salt. Since, however, helium technology will be developed for HTR's and it should pose less materials problems, study of the possible use of helium in an MSFR, which will require careful consideration of the safety issues of a pressurised coolant, should be undertaken.

- (ii) the chemistry of the chloride salts proposed for fuel and blanket shows, on the limited work to date, encouraging signs of being controllable to the required degree; but both in this area, where the effects of potential precipitating species (eg, due to oxygen and nitrogen from adventitious air ingress, sulphur from Cl-35, fission products) and the possible deposition of noble metal fission products need study. In the materials and corrosion fields, much more work is clearly needed. The extent of the materials work will be affected by the choice of secondary coolant, but it is evident that considerable reliance will have to be placed on the demonstration of good corrosion performance and development in the technique of fabrication of molybdenum or its alloys for the key components (eg, core vessel and heat exchangers) of the core and blanket circuits. Suitable design should enable more conventional materials to be used for the main vessels and other components.
- (iii) there appear to be good prospects of being able to operate an MSFR without conventional nuclear control systems. This together with the avoidance of refuelling equipment, offers the possibility of a compact system with more the character of a chemical plant. It is from these possibilities that the potential for capital cost savings compared with an LMFBR can be discerned, but there are the important areas of containment, emergency dumping and ancillary systems requiring further investigation to assess any off-setting effects.
- (iv) the reference lead-cooled indirect design of this report is inferior to a 1990 oxide-fuelled LMFBR in fuel inventory but current evidence suggests that an increase in primary salt top temperature could be contemplated to a level where the inventories are comparable. The doubling times with natural chlorine in the salt would then also be comparable, and if separated Cl-37 were used doubling times in the range 20-25 years seem possible.

NOT FOR PUBLICATION (COMMERCIAL)

- (v) the preliminary costing (which is all it has been possible to carry out), indicates that the reference MSFR has potential for savings relative to a 1990 LMFBR both in the capital cost (about £12-20/kWe) and fuel cost areas (£8/kW). The increased top temperature scheme referred to in (iv) shows further gains of £5/kW for capital and £5/kW for fuel costs, the latter reflecting the reduced inventory charges with plutonium taken at £5/gm. These costs are for natural chlorine salt; Cl-37 although giving the gains in doubling time already mentioned, leads to a slightly higher fuel cost because of increased inventory charges, so its use must be judged (apart from any chemistry gains in reducing the amount of sulphur formed from Cl-35) on its value in an overall generating system where increased installation rates can have discounted worth.
- (vi) the fuel costings have taken aqueous solvent extraction as the process of for heavy metal handling and show favourable results. It is not therefore necessary to invoke a close-coupled pyrochemical method, and indeed the preliminary investigations made, while indicating technical feasibility, raised doubts about the costs of this method with the small scale batching technique considered; this is an area requiring further examination.
- (vii) the investigations reported here have indicated the value of the intrinsic self-regulatory characteristics of the MSFR with its favourable temperature coefficient, and the potential for fuel dumping in the event of faults but have also brought out the importance of further careful study of fault conditions, including cross-leakage with a fluid fuel, and of containment requirements.

11. Parameters for Indirect and Direct Cooled Versions of a Molten Salt Fast Reactor - Summary

Reactor power (total)	MW(th)	6000
Gross electrical output	MW(e)	2 x 1350
Nett electrical output	MW(e)	2 x 1250
Steam conditions - TSV	MN/m ²	16.3
	psig	2350
	°C	565
Overall plant thermal efficiency	%	41.8
Fuel salt	NaCl:UCl ₃ :PuCl ₃	60/37/3 mol %
Blanket salt	NaCl:UCl ₃	60/40 mol %
Melting point		577°C (850 K)

NOT FOR PUBLICATION (COMMERCIAL)

	Indirect			Direct
	1	2	3	4
Design No				
Coolant	Lead	Lead	Helium	Lead
Fuel salt properties used	(2)	(1)	(1)	(2)
Volume of core	m ³ 17	16	16	37
Fuel salt volume external to core	m ³ 21.5	28	22	15-18
Total breeding gain	0.29	0.3	0.3	0.53
Doubling time (net)	years 25	28	24	21
Core inventory (including external volume)				
- Pu-239 equivalent	te 9.5	10.8	9.4	9.2
- U-238	te 63	72	62	60
- Cl	te 55	48	54	49
- Na	te 11	13	11	10
Volume of blanket/external volume blanket salt	46/5	48/17	53/22	83/5
Blanket inventory - U-238	te 84	107	124	165
- Cl	te 68	87	100	116
- Na	te 14	18	21	2 ^b

(1) Thermal conductivity taken as $K = 0.5 \text{ w m}^{-1} \text{ k}^{-1}$.

(2) 70:30 fuel salt properties used with MP 557°C and $K = 2.0 \text{ w m}^{-1} \text{ k}^{-1}$ for heat transfer calculations.

Neutrons Fluxes

Approximately applicable to all designs

(a) Max.	n/cm ² s	2 x 10 ¹⁶
(b) At core/blanket Membrane	n/cm ² s	5 x 10 ¹⁵
(c) At Outer Vessel	n/cm ² s	3 x 10 ¹⁴
(d) At heat exchangers	n/cm ² s	3 x 10 ¹³

Core Conditions

	Design	1	2	3	4
Power developed in core	MW(th)	5700	6000	6000	5700
				Mean temp	
Core inlet temperature	°C	650	660	670	680
Core outlet temperature	°C	810	810	970	800

NOT FOR PUBLICATION (COMMERCIAL)

Max pressure in core vessel	KN/m ²	1630	970	3140	4000/2700
	psi	236	140	454	580/390
Specific power rating:-					
(a) based on net core volume	MW/m ³	340	375	375	154
(b) based on total volume including external fuel salt volume	MW/m ³	154	138	158	110

Core Heat Removal

Coolant		Lead	Lead	Helium	Lead Curtain
Number of coolant circuits		8	8	10	8
Fuel salt flow (each)	m ³ /s	2.45	3.14	1.22	Internal
Coolant flow (each)	m ³ /s	3.6	4.6	260 kg/s	1.7
Coolant inlet/outlet temp	°C	480/600	570/670	400/850	370/630

Core Salt

Heat exchangers (same number as coolant circuits)

LMTD	°C	190	112	190	-
mean heat flux	w/cm ²	372	106	107	-
Max heat flux	w/cm ²	410	147	155	-
Tube ID/OD	mm	9/12	9/10	6/8	
Pitch of tubes	mm	19.2 □	11.5 Δ	14.4 □	
Number of tubes		3600	12,080	6164	
Heat transfer length/ overall length of tubes	m	1.5/2.9	2.0/2.5	3.6/4.1	

Blanket Conditions

Power developed (assumed for design purposes - up to 15% ie 900 MW(th) could be developed after a 10 year fuel cycle)	MW	300	900	900	300
Blanket inlet temperature	°C	600	660	630	600
Blanket outlet temperature	°C	650	760	700	650
Max pressure	kW/m ²	1630	1000	3300	1630
Effective blanket volume	m ³	46	48	53	83
Total blanket salt volume including cooling circuits	m ³	51	65	75	88

NOT FOR PUBLICATION (COMMERCIAL)

Blanket Heat Removal

Coolant as for core					
Number of coolant circuits	m ³ /s	4	4	5	4
Blanket salt flow (each circuit)	m ³ /s	0.8	1.43	1.7	0.8
Coolant flow (each)	m ³ /s	0.7	2.1	116 kg/s	0.7
Coolant inlet/outlet temp	°C	480/550	570/636	400/600	480/550

Blanket Salt Heat Exchangers

LMTD		190	100	155	190
Mean heat flux		372	95	107	372
Tubes ID/OD	mm	9/12	9/10	6/8	9/12
Tube pitch	mm	19.2 □	11.5 □	11.0 □	19.2 □
No off		565	5500	5900	565
Heat transfer length/overall length		1.5/2.0	1.5/2.0	1.3/1.8	1.5/2.0

Pressure Drop

Fuel salt side: Core & ducts	KN/m ²	183	970	970) Internal
Heat exchgrs	KN/m ²	1450	1670	2170	
Coolant (IHX : Heat exchgrs circuit)	KN/m ²	812	1050	148) 5000/10000 (nominal)
Pipework	KN/m ²	184	300	70	
Coolant (steam generator circuit)					
Steam generators and pipework	KN/m ²	1290	700 (if 670°C upper temp is acceptable)	-	700

Pumps

<u>Fuel Salt Pumps</u>		No off	8	8	10	-
Duty (each pump)	Flow	m ³ /s	2.45	3.14	1.22	-
	Δp	KN/m ²	1630	2640	3140	-
At 70% overall efficiency	Power	MW	5.7	11.8	5.5	-
Power normalised to 6000 MW produced in core		MW	6.0	11.8	5.5	-

<u>Blanket salt pumps</u>		No off	4	4	5	4
Flow		m ³ /s	0.8	1.43	1.7	0.8
	Δp	KN/m ²	1630	2640	3140	-

NOT FOR PUBLICATION (COMMERCIAL)

At 70% overall efficiency	Power	MW	1.9	5.3	7.5	1.9
Power normalised for 900 MW(th) produced in blanket		MW	5.7	5.3	7.5	5.7
<u>Coolant Pumps</u>						
(a) Core IHX only	No off		4	4	5	8
	Flow	m ³ /s	3.6	4.6	260 kg/s	1.7
	Δp	KN/m ²	996	1350	218	5000-10,000
	Power	MW	5.1	8.8	13.4	12-24
(b) Core IHX + blanket HX	No off		4	4	5	4 (blanket HX only)
	Flow	m ³ /s	5.7*	6.7	376	2.1*
	Δp	KN/m ²	996	1350	218	996
	Power	MW	8.1*	13.0*	19.5*	3.0*

* For 900 MW(th) blanket power

<u>Total Design Pumping Power</u> (excluding steam side)	Design	1	2	3	4
Fuel salt	MW	48	94	55	-
Blanket salt	MW	23	21	30	23
Coolant (a) IHX circuit, incl by-pass	MW	52	87	136	108-200
(b) Steam generator circuit	MW	34	14	-	14
		157	216	221*	145-237

∕ Combined installed pumping power for 6000 MW(th) from core and 900 MW(th) from blanket. In operation total power from core and blanket would be 6000 MW as designed, therefore power consumed by pump would be reduced to 87% of the design total capacity assuming perfect distribution, etc.

* Includes nominal power for loss of Δp in coolant ducts to turbine but no losses in turbine plant, intercooler, precooler or recuperator. All coolant pressure drop will be made good by the turbine driven compressors and all coolant pumping power is included in the overall plant efficiency, ie about 41% with reasonable recuperation.

Steam Generator Conditions

The conditions quoted are applicable to Design 1. Little or no bypass flow would be required for Design 4. Probably greater bypass flow would be required for Design 2, depending upon the maximum temperature difference that can be tolerated in the evaporator section to limit lowest lead temperature, if the superheater or reheat sections impose limits of upper lead temperature a second bypass may be required. The helium cooled

NOT FOR PUBLICATION (COMMERCIAL)

(1 and 2 are combined during a fast dump so that they will contain, between them, all the fuel salt and one of the eight steam generator circuits lead inventory of total volume $37 + 51 + 160$, ie, 247 m^3 + allowance for expansion tank capacities total 260 m^3).

Cooling for each tank, based on assumption that all the core and blanket arrives in one tank $2\frac{1}{2}\%$ of full power assumed, subject to further investigation.

MW 150

Combined 1st stage delay tank and core or blanket auxiliary drain tank.

Net volume (Divided into two equal parts if core and blanket is to be processed separately)	m^3	100
--	--------------	-----

Maximum head	m	18
--------------	---	----

Design pressure (to give interchangeability)	MN/m^2	1.2
--	-----------------	-----

Maximum temperature	$^{\circ}\text{C}$	750
---------------------	--------------------	-----

Cooling provided	Not yet assessed	
------------------	------------------	--

2nd Stage delay tank

Net volume (Divided into two equal parts if required as above)	m^3	20
---	--------------	----

Head, design pressure and max temperature as for 3

Cooling provided	Not yet assessed	
------------------	------------------	--

Off-gas system delay beds

(No detailed calculations carried out, Volume pro rata to MSBR power). Each tank contains water cooled charcoal filled U tubes

No units		16
----------	--	----

Volume each (h = 2 x 8m dia = 5.5m)		38 m^3
-------------------------------------	--	------------------

Total volume		610 m^3
--------------	--	-------------------

NOT FOR PUBLICATION (COMMERCIAL)

Cooling requirements	Not yet assessed	
(Pro rata MSBR: 47 hr hold up system		7.5MW
Long delay system		0.7MW)

10.6 Lead Filling and Drain Tanks

No of units		16
Volume each	m ³	20 (10m long x 1.6 m dia)
(each tank will hold contents of one intermediate circuit)		
Maximum head (of lead)	m	18
Design pressure	MN/m ²	2.1
Design temperature	°C	500

11. Off-gas system

Notional values based on MSBR

Helium purge flow rate	atm l/s m ³ /s	14 1.4 x 10 ⁻²
Nominal working pressure, bar of system (equal to that of primary pump suction)	psig	2 15

Fission product flow
rate in helium
stream is approx-
imately 0.1%

12. Cleanup system

The highest flow rate is that required
for UCL₄ reduction, based on SG/MSFR
(71)P13 flow rate required:

	l/s	2.3
	m ³ /s	2.3 x 10 ⁻³
	GPM	31

Component weights

	Matl Vol m ³	Matl Wt Te
Reactor vessel including nozzles, flanges	9	68.8

NOT FOR PUBLICATION (COMMERCIAL)

Molybdenum core shell including outer liner, tube liners to HX's	1.4	14.3
Main heat exchanger shell only - (1 off)	2.52	19.2
HX tubes and tubeplates (0.53m ²) and (0.4m ²)	0.93	5.3 (tubes) 4.1 (tubeplates)
HX connecting pipework (1 set)	0.19	1.45
Blanket cooler HX shell Only - (1 off)	0.4	3.06
Blanket cooler HX tubes and tubeplates (0.08m ²) and (0.09m ²)	0.17	1.3
Cooler connecting pipework (1 set)	0.21	1.55

	Total weight (te) of	Mb	Alloy Steel and Steel
Reactor vessel		-	68.8
Core shell (Mb)		14.3	-
HX shells (8 off)		-	153.6
HX tubes (8 sets)		42.4	-
HX tubeplates (8 sets)		-	32.8
HX connecting pipework (8 sets)		-	11.6
Blanket cooler shell (8 off)		-	24.5
Blanket cooler tube and tubeplates (8 off)		-	10.4
BC connecting pipework (8 sets)		-	12.4
	Totals	<u>56.7</u>	<u>314.2</u>

REFERENCES

1. EIR-Bericht Nr 215 Molten Chlorates Fast Breeder Reactor. Problems and Possibilities. M Taube, J Ligou.
2. ORNL 4541. Conceptual Design Study of a Single Fluid Molten Salt Breeder Reactor. Compiled and Edited by Roy C Robertson.

NOT FOR PUBLICATION (COMMERCIAL)

ACKNOWLEDGEMENTS

This report summarises the results of work at Culham, Harwell, Risley and Winfrith. Acknowledgement is due to the following:-

Culham

Mr J Adlam
Mr T Dullforce
Mr R S Peckover
Dr J A Reynolds
Mr R T Whipple
Mr J D Jukes
Dr K V Roberts

Risley

Mr R H Allardice
Mr J E Shallcross

Winfrith

Mr D M Harris
Mr W C May
Mr J E C Mills
Dr D L Reed
Mr G L Shires
Mr W E Simmons
Mr R J Symes

Harwell

Dr R C Asher
Dr J K Dawson
Mr B L Eyre
Mr B R Harder
Mr F Hudswell
Dr C F Knights
Mr A E Little
Dr G Long
Dr H P C McKay
Mr S F Pugh
Mr J C Ralph
Mr D Scargill

APPENDIX I

FEATURES OF THE DIRECT SYSTEM

Considerable effort has been devoted to preliminary consideration of the mechanics of fluids and heat transfer in a MSFR which is directly cooled by a curtain of lead droplets falling through the fuel salt in the outer regions of the core. The lead would then flow to steam generators as in the indirect case.

The main problems in a directly cooled MSFR are:-

- (a) to achieve a sufficiently high core rating to give a reasonable fuel inventory
- (b) to disentrain the salt from the lead flow so that as much as possible of the salt remains in the core
- (c) to prevent lead droplets recirculating within the core and causing an excessive build up in the central region.

Very little experimental evidence is yet available, but from theoretical considerations it appears that core rating is limited to 70 MW/m^2 for free gravity fall of the lead curtain, and to meet economic fuel cycle costs a rating of not less than 150 MW/m^2 is required. This could in principle be achieved by inducing poloidal flow of the core salt with lead flow injected helically at 30° to the horizontal (to increase the path length for heat transfer and separation) at velocities in the range of 20 to 30 m/s to give mean salt velocities of about 10 m/s.

Theory indicates that to achieve the required rating a curtain of lead droplets of 3 mm mean diameter and a packing fraction of 0.35/0.4 is necessary; jet pumps would be required at the lead injection point to accelerate the salt to give low velocity slip relative to the high lead velocity required for the necessary throuput.

A core height/diameter ratio in the region of 1.5 is probably required to give sufficiently long paths for heat transfer and separation of the lead from the salt in the lower core regions.

Preliminary experiments have indicated that heat transfer is likely to be adequate. A theoretical model was established to combine the heat transfer with the separation but the performance of the latter aspect is very doubtful as little experimental work has been done at velocities and densities approaching the real case. A further limit on performance arises from the hydraulic losses in the core as lead jet velocities in excess of 20 m/s would require pumping powers greater than that of the indirect system and local losses in the jet pump region would be high. Another area of uncertainty is how, following the downward helical flow in the outer regions,

NOT FOR PUBLICATION (COMMERCIAL)

the salt can be induced to flow smoothly upwards in the central region of the core and enter the jet pump inlets without undue losses or the need for elaborate guidance systems. A large amount of experimental and theoretical work would be required to investigate these problems and it appears that alternative coolant patterns would have similar uncertainties.

Figure 4b is an illustration of an attempt to combine the features discussed above and shows a radial arrangement of jet pumps with the lower part of the core vessel shaped to give coarse separation within the core and further separation by means of curved ducts at the core exit.

As the quantity of lead flowing is $10^6 \text{ m}^3/\text{day}$, very efficient separation to ppm levels is required to prevent excessive salt hold up in the external lead circuit itself, where in addition salt freezing could occur on the cooler surfaces of the steam generators. In the latter case daily or even more frequent thermal cycling would be required to reduce the total amount building up.

In the absence of information on performance or cyclone separators under these conditions, it has been assumed that two stages of cyclonic separation will be adequate and a tentative reactor layout as shown in Figure 4a has been drawn up. The parameters given in this Appendix, which also apply to Design 4 referred to in the Main Report, have been drawn up on this basis.

The use of jet pumps and lead separators external to the core has been shown to involve too great an inventory.

Steam generators would be similar to that proposed for the indirect system. There is no restriction on the lead return temperature to the reactor as long as it is above its melting point but the upper limit of reactor outlet lead temperature will depend on thermal stresses in the steam generators. Two sets of lead pumps are arranged in series with a steam generator by-pass. This arrangement allows flows meeting the core hydraulics and heat transfer requirements and the steam generator requirements to be adjusted independently since it cannot be assumed that these would match the pumping pressure in the reactor.

To maintain the correct flow pattern and separation conditions in the core almost constant flow seems desirable. Power control would be achieved by changing the coolant temperature range using the steam generator by-pass or possibly by changing the depth of lead pool in the bottom of the reactor, thus varying the amount of fissile salt in the core.

In order to avoid any difficulty with increase of reactivity in the immediate period following a cessation of lead flow, a U-leg is provided in the lead entry lines, which ensures that salt will be displaced from the core region by a lead pool building up at the bottom of the core vessel.

NOT FOR PUBLICATION (COMMERCIAL)

Blanket cooling will be indirect using external heat exchangers as it would be difficult to provide the correct geometry for direct cooling (for which the basic requirement does not exist as ratings are comparatively low and inventory considerations are not so restrictive).

TABLE A.1

MSFR DIRECT LEAD CURTAIN COOLED SYSTEM - PARAMETERS

NB All values quoted are nominal and based on preliminary information which is subject to change.

Core Model - Helical poloidal flow with jet pumps

Nominal rating 150 MW/m³

Core thermal power	MWt	5700
Blanket thermal power (5% of total)	MWt	300
Core height	m	5
Core diameter	m	3.2
Gross core volume	m ³	40
Specific power in core	MW/m ³	142

Lead Coolant

Total lead flow rate to core	Kg/s	142,000
	m ³ /s	13.5
Temperature at core inlet	°C	370
Temperature at core outlet	°C	630
Mean core salt temperature	°C	680
Maximum core salt temperature	°C	800

Typical Curtain Conditions

Angle of descent of lead	0	30°
Curtain width	mm	(1) 600 (2) 680
Lead fraction in curtain		0.4 0.35

NOT FOR PUBLICATION (COMMERCIAL)

Curtain inner diameter	m	2.0	1.84
Horizontal c.s.a. within d = 2m	m ²	3.14	2.65
Horizontal curtain c.s.a.	m ²	4.86	5.35
Salt flow rate (approx)	m ³ /s	20	25
Mean lead velocity in curtain	m/s	10.5	9
Salt velocity in curtain (approx)	m/s	10.0	9.95

Jet Pump Conditions

NB It is assumed that the salt enters vertically

Angle of jets and vanes to horizontal	0	(1) 30°	(2)
Lead injection velocity	m/s	30	20
Salt velocity in throat	m/s	29	19
No of jet pumps (not optimised)		60	60
Pitch		6°	6°
Length of slot in each unit	mm	600	600
Mean width of slot	mm	13.2	16.5
Thickness of slot sides (each)	mm	1.4	1.9
Overall mean width of injection slot at outlet	mm	16	20.3
Mean width of salt passages either side of slots	mm	10	16
Mean width of blading between jet pumps at throat	mm	34	15
Ratio outlet area/throat area (<u>Note:</u> Further deceleration must occur in curtain zone)		1.9	1.28

<u>Lead Circuit Pressure Drop</u> (based on jet velocity of 20 m/s)	V m/s	p KN/m ²	Possible extra KN/m ²
	<hr/>	<hr/>	<hr/>
Top plenum	3	30	
Inlet to jets	20	500	+500

NOT FOR PUBLICATION (COMMERCIAL)

KE loss at jet	20	1500	+500
PE due to height of core		350	
Outlet duct (150° bend)	10	500	
Friction		50	
Cyclone separators (1 set)	6.7	1180	+1180 (if second set)
External lead circuit inc. steam generators		900	
		<hr/>	
		5040	+2180
		=	7220

Thus the overall pressure drop of the lead lies between 5000 kW/m² (725 psi) and 3000 kW/m² (1160 psi) for jet pump velocities of 20 m/s.

The pressure drop might increase to 10,000 kW/m² (1450 psi) for 30 m/s jet velocity (i.e. an additional 2000 kW/m²).

Total pumping power including 20 MW(e) for blanket would be 117 MW(e) minimum based on 20 m/s jet velocity and one set of separators or possibly double this figure if 30 m/s jet velocity and two sets of separators are required.

Volumes and fuel salt inventory

(very approximate)

Core	m ³	37
Blanket (5 m high x 3.2 m ID x 5.2 m OD)	m ³	83
Lead in reactor vessel when running	m ³	30
Lead in 1 set of 16 separators and connecting pipework	m ³	70
. . . amount of lead containg salt	m ³	100
(If second set of separators required	= m ³	172)
For 5% salt content in lead	m ³	5
(With two sets separators	m ³	8.6)
Volume of salt in return lines	m ³	5.6

NOT FOR PUBLICATION (COMMERCIAL)

Lead in steam generator circuits (8)	m ³	1000
Salt content if 0.5%	m ³	5
Possible total salt inventory outside core = <u> </u>		15 m ³ (or 18.6 m ³ if two sets of separators)
Dump Volumes for all core + lead (of 260 m ³ for indirect system with one lead circuit dumped)		1200 m ³ (excluding blanket)

Pressures (20 m/s jet velocity)

	<u>KN/m²</u>	<u>Psi</u>
At rest (no circulation) at bottom of separators	727	105
When running (1) at bottom of core (due to back pressure from separators)	2700	390
(2) Internal pressure in jet slots between 2800 and 4200 KN/m ² depending on situation of losses	3500	500
(3) Differential pressure between salt and lead in slots	1500	220

APPENDIX II

INTERNALLY COOLED MSFR

1. INTRODUCTION

The possibility of internally cooling the core of a MSFR using a tubed heat exchanger situated in the outer core region and blanket salt or lead cooling was considered in the early stages of the recent MSFR work. Within the limits of salt temperature considered at that time (i.e., 800°C) the performance was poor and gave very low breeding due to the absorption effects of the material in the core.

Taube⁽¹⁾ has since proposed a system in which the whole core is virtually occupied by cooling tubes through which blanket salt is passed. This has the merit of removing the heat at source and although an upper salt temperature of 998°C is quoted, the maximum tube wall temperature under normal operating conditions is 854°C. Some comments on this concept are given below.

2. DISCUSSION

Examination of EIR Bericht Nr 215⁽¹⁾ indicated that the reactor physics results quoted had been based on Bondorenko's data and from previous experience it was known that this data set would produce a much harder spectrum (and therefore more probably a more favourable performance) than with the FD4 set used for the MSFR studies. To study this further, some calculations with FD4 on a simplified model of the Taube concept were carried out and these indeed revealed that FD4 would give much lower levels of breeding gain, so much so that it required the replacement of natural chlorine by Cl-37 to bring values back to those quoted by Taube. Ligou⁽²⁾ has repeated the calculations for the Taube concept using data from the GGC3 file. This gave a somewhat higher critical mass than in the initial report or in the FD4 calculations, but a breeding gain close to that of EIR-215, i.e., substantially higher than FD4. The latter difference appears to be mainly due to the much lower average chlorine cross-section of the data Ligou used. Clearly there is scope for further comparative work and improvement of data.

Another potential source of difference which could depress the performance of the concept proposed by Taube was that the thermal property data used in the reference MSFR cases were materially less favourable than those used in EIR-215 and this could have a substantial effect on a scheme in which good heat transport and heat transfer within the reactor core is highly important if too much neutron absorbing material for the heat transfer surfaces is to be avoided.

It was therefore decided to carry out an outline study of the concept using data as used for the MSFR studies, and for a 6000 MW(t) size, so as to be able to make a comparison with the indirectly cooled version.

3. OUTLINE SCHEME

It was assumed that the blanket salt, from which with this scheme both the core heat and that generated within the blanket itself has to be removed, is circulated to external coolers similar to the intermediate heat exchangers of the indirectly-cooled design but readjusted to take advantage of the less costly inventory effects of blanket salt compared with core salt. It was further assumed that a secondary coolant would be needed for possible leakage and containment reasons.

The effect of the poorer physical property data is substantial. In the Taube arrangement the cooling tubes extend across the whole core region and a low core salt velocity of about 2 m/sec is all that is needed. With the MSFR data, core salt velocities have to be much higher and even at 5 m/sec which was taken as a typical permissible upper limit, the maximum salt temperatures are in the range 1100/1160°C with tube wall temperatures of 900°C for the same secondary coolant conditions as in MSFR (indirectly-cooled). Furthermore the considerable increase in circulation rate of the core salt necessitates the use of large pumps and the core has been rearranged to put heat exchange surfaces on as large a diameter as possible to give reasonably low velocities across the tube banks. Figure 12 shows a schematic arrangement in which a clear central zone is created to reduce the cross flow velocities and forms a continuation of the pump diffusers so as to minimise inventory. Blanket salt velocities must be kept up if tube-wall temperatures are not to become excessive and this leads to high pumping powers and very high pressure differentials.

Physics calculations were made using a simplified cylindrical approximation to the arrangement of Figure 12 and they immediately brought out the importance of minimising tube wall thickness and pitch to reduce fuel inventory as illustrated in Table 1.

The parameter list of Table 2 is based on tubes of 3 m length, 5.0 mm.i.d., and 5.6 mm.o.d., on a pitch/diameter ratio of 1.3. This tubing is very thin walled and may have exceeded the practicable lower limit. It would need thorough testing and demonstration.

4. PERFORMANCE

The preliminary investigations of the internally cooled MSFR described indicate good nuclear performance. The Pu-239 inventory of between 6 and 7 te for 6000 MW(th) is low, comparable to Taube's proposal, and less than for the indirectly-cooled systems described although for similar maximum salt temperatures the differences would be small.

The estimates indicate a reduction of doubling time from 25 years for an indirect system to 20 years for the internally cooled Cl-37 system on the basis of external reprocessing (by aqueous methods) where the external hold up represents a significant fraction of the system inventory. Clearly as potential reactor performance improves, the incentive to develop close-coupled reprocessing increases. This reduction in doubling time is made

NOT FOR PUBLICATION (COMMERCIAL)

at the expense of high temperatures in the plant and with heat exchanger tubing subject to high neutron fluxes, although damage may anneal out. Also there is the requirements for an additional set of full capacity heat exchangers external to the reactor.

A first estimate suggests that the capital and running costs due to the extra heat exchangers and high total pumping power with the extra cost of Cl-37 in the external heat exchangers cooling the blanket almost offset the saving in fuel inventory; thus there is little direct economic gain.

5. CONCLUSIONS

In principle an internally-cooled system should offer the prospect of low fuel inventory and although this preliminary study has not shown the margins compared with the indirectly cooled system that initially seemed possible, the concept is sufficiently interesting to justify further investigation to optimise the nuclear and thermo-hydraulic performance. If results are encouraging further investigation will be required to determine the limits of corrosion and strength of Molybdenum or its alloys at temperatures up to 1200°C. The design problems associated with high velocities and high pumping pressures will need far more consideration than has been given in this outline scheme.

TABLE 1

NUCLEAR PERFORMANCE OF A PRELIMINARY UKAEA DESIGN OF AN
INTERNALLY COOLED 6000 MW(t) MSFR USING CL37 SALT

Heat exchanger tubing pitch/diameter ratio	Effective core Volume (1)	Critical Mass (Pu239)	Total Breeding Gain	With 9 months processing hold-up			Without hold-up
				System Inventory	Specific System Inventory	Doubling Time	Doubling Time
	M ³	te			<u>Kg/Pu239</u> MW(t)	Years	Years
1.3	12.5	2.31	.225	5.94	0.99	19.9	11.7
1.7	19.8	3.85	.253	7.26	1.20	19.1	14.0

- (1) The effective core volume including some of the salt in the connections from the pumps to the core heat exchanger tubing.

NOT FOR PUBLICATION (COMMERCIAL)

TABLE 2

MSFR Internally Cooled Design Parameters

Maximum core power (at start fuel cycle)	MWth	6,000
Height of core (selected)	m	3.0
<u>Core-Blanket Heat Exchanger (in core)</u>		
Number of tubes (in annular form)		60,000
Tube internal/external diameter	mm	5/5.6
Pitch/outer diameter ratio		1.3
Pitch geometry		Square
<u>Dimensions</u>		
Upper central uncooled zone core diameter	d ₁ m	0.72
Lower central uncooled zone core diameter	d ₂ m	1.5
Outer lower core overall diameter	d ₃ m	2.5
Pump suction diameter (for 4 pumps) each	d ₄ m	0.63
<u>Volumes</u>		
Fuel salt in core zone (incl HE)	m ³	8.6
Fuel salt external in pumps and connections	m ³	2.5
<u>Flow rates</u>		
Fuel salt flow rate	m ³ /s	12.4
Fuel salt velocity in HE	m/s	7
Blanket salt flow rate	m ³ /s	17.6
Blanket salt flow velocity in HE	m/s	15
<u>Heat transfer coefficients</u>		
Fuel salt/wall	W/cm ² °C	1.1
Wall (0.3mm thick molybdenum)	W/cm ² °C	35.0
Wall/blanket salt	W/cm ² °C	1.9
Overall	W/cm ² °C	0.6
<u>Heat Flux</u>		
Mean heat flux	W/cm ²	190
<u>Temperatures</u>		
Log mean temp difference required	°C	317
Uncooled core zone temp rise	°C	124
LTD/GTD	°C	290/390
Max fuel salt temp		1100
Blanket salt inlet/outlet temp to HE	°C	590/810
<u>Pressure drop (coreheat exchanger only)</u>		
Blanket salt Δp	MN/m ²	6.5 (950 psi)
Fuel salt Δp	MN/m ²	1.2 (173 psi)

NOT FOR PUBLICATION (COMMERCIAL)

Pumping power (core heat exchanger only)

Fuel/Blanket salt

MW(e)

21/164

- 1 CORE
- 2 BLANKET
- 3 INTERMEDIATE HEAT EXCHANGER-8off
- 4 FUEL SALT PUMP-8 off
- 5 BLANKET COOLER-4 off
- 6 BLANKET COOLER PUMP-4 off
- 7 ISOLATION VALVE
- 8 LEAD INLET
- 9 LEAD OUTLET
- 10 GRAPHITE
- 11 HIGH TEMPERATURE
RESISTANT LINING
- 12 DRAIN LINE
- 13 FLOW DISTRIBUTOR
- 14 SUPPORT FLANGE

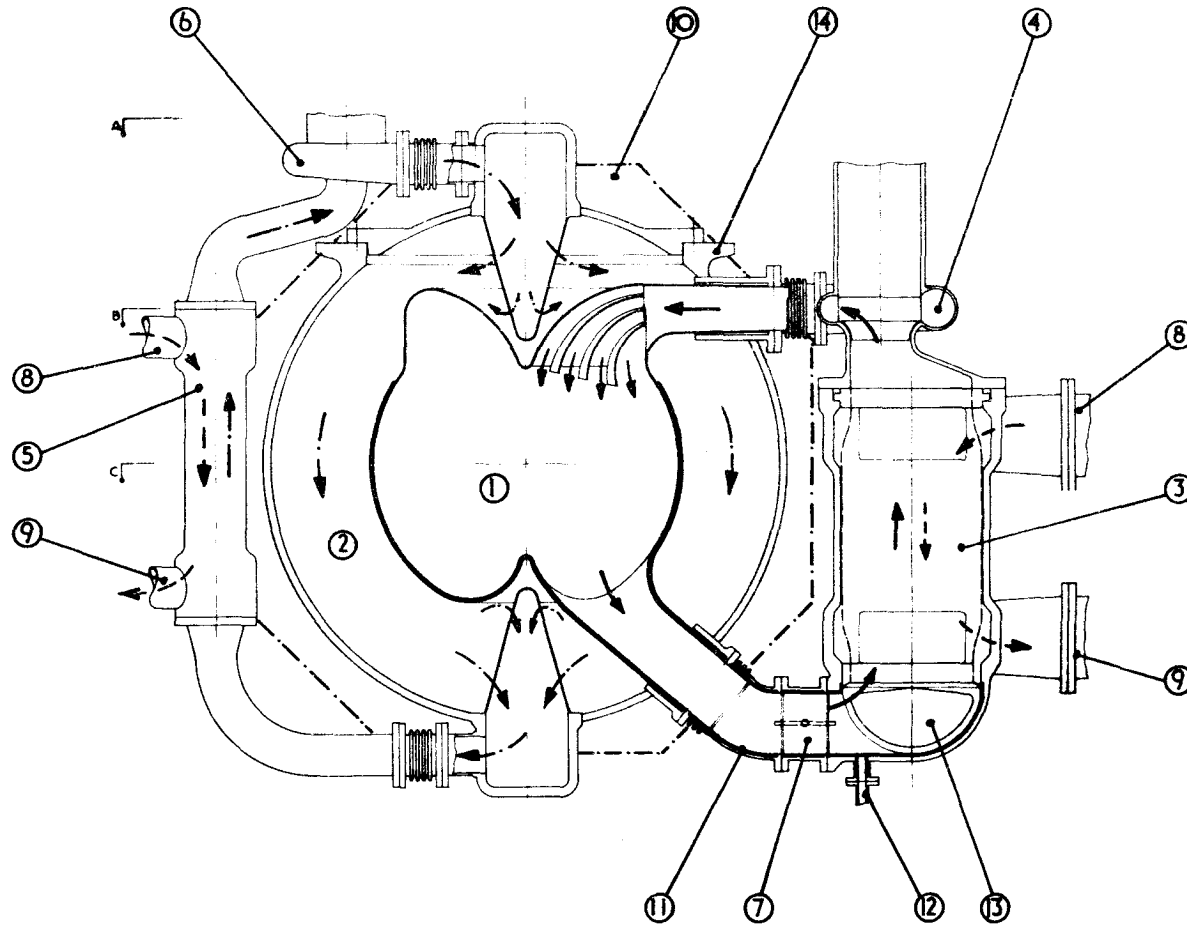

DESIGN I
INDIRECTLY COOLED M.S.F.R.
(LEAD COOLED)
6000 MW Th

FIG. 1a

TOTAL CORE SALT INVENTORY

SCHEME 'A' - 42.81 M³

SCHEME 'B' - 40.09 M³

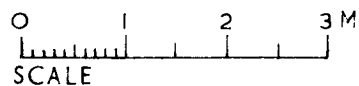
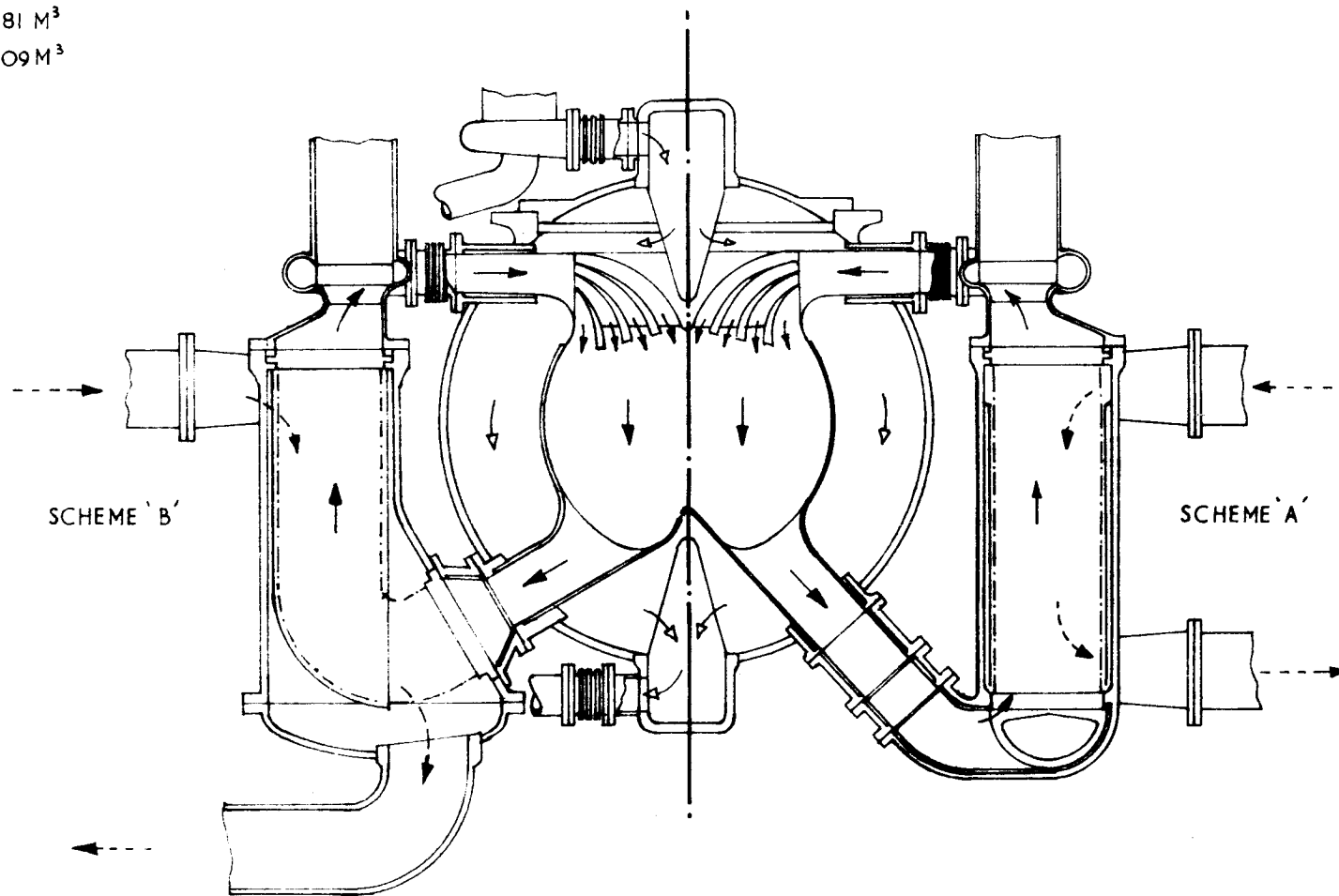

M.S.F.R.- ALTERNATIVE DESIGNS OF INTERMEDIATE
HEAT EXCHANGERS FOR LOW CONDUCTIVITY FUEL SALTS

FIG. 1b

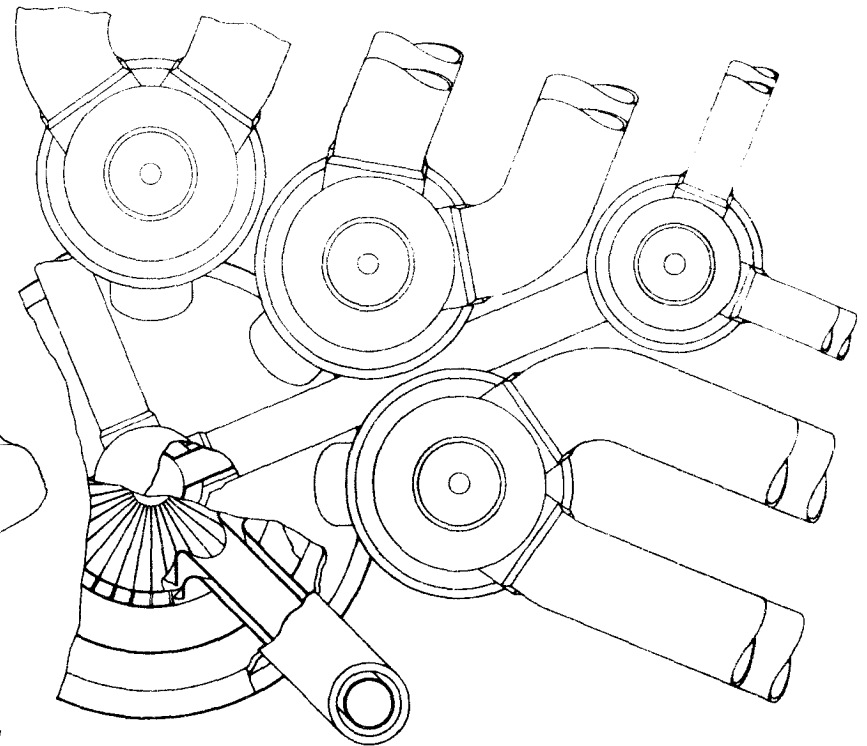
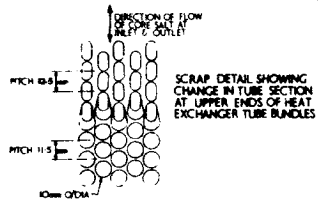
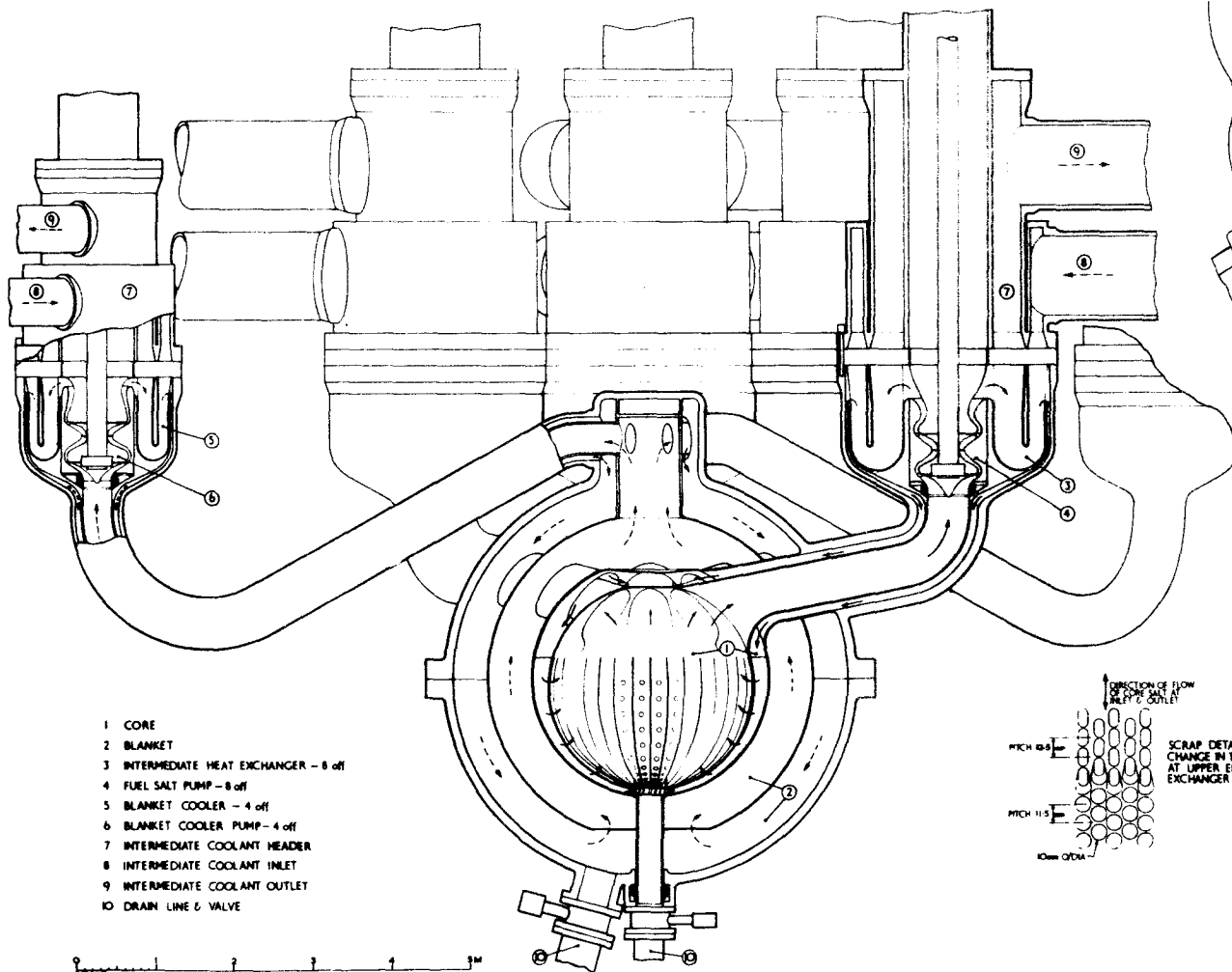

DESIGN 2
 INDIRECTLY COOLED M.S.F.R.
 (LEAD COOLED)
 WITH ALTERNATIVE CORE & INTERMEDIATE
 HEAT EXCHANGER LAYOUT
 6000 MW Th.

FIG. 2

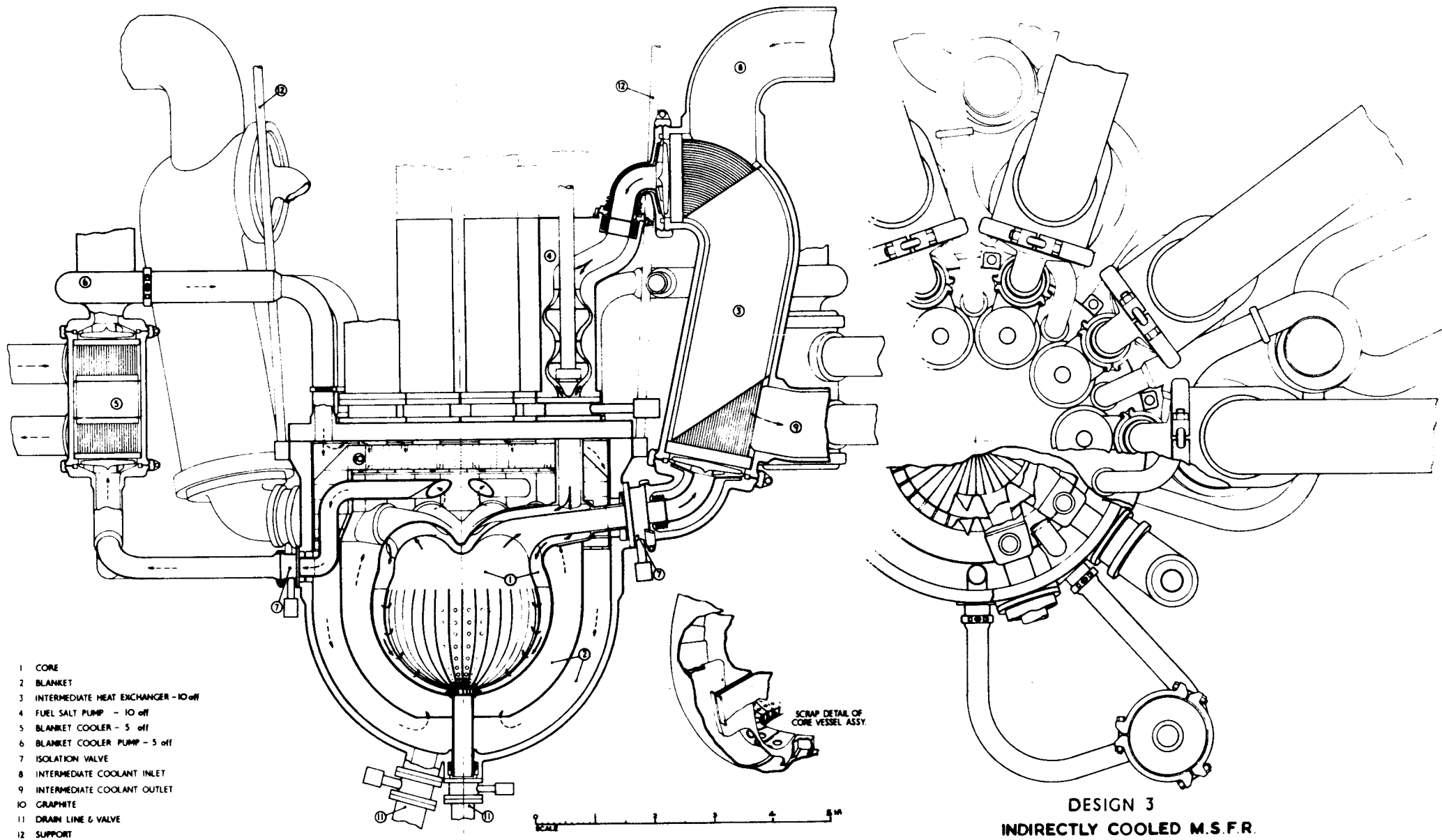

DESIGN 3
 INDIRECTLY COOLED M.S.F.R.
 PRELIMINARY DESIGN OF
 HELIUM COOLED VERSION
 6000 MW Th.

FIG. 3

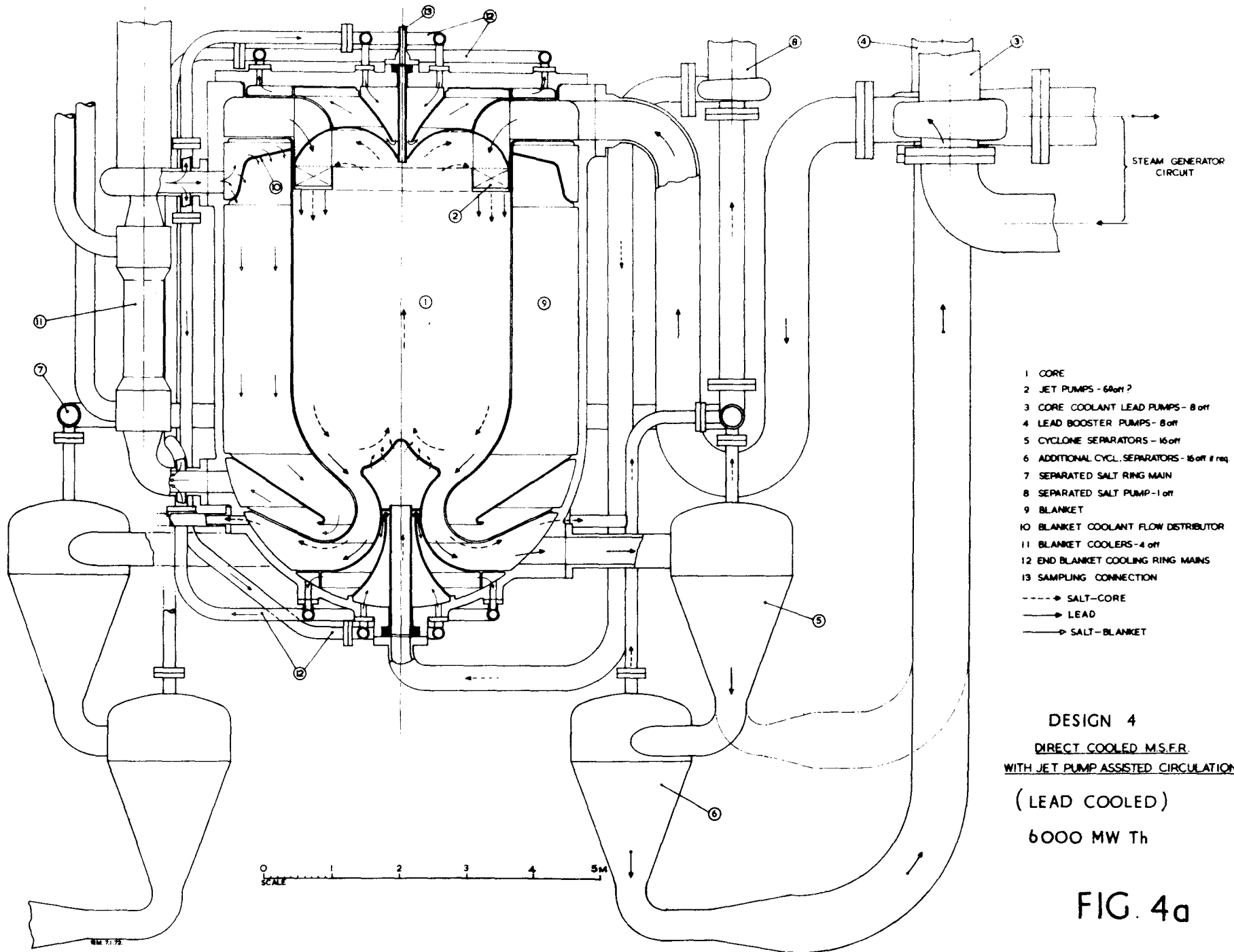

DESIGN 4
 DIRECT COOLED MSFR
 WITH JET PUMP ASSISTED CIRCULATION

(LEAD COOLED)
 6000 MW Th

FIG. 4a

➤ CORE SALT

➤ LEAD

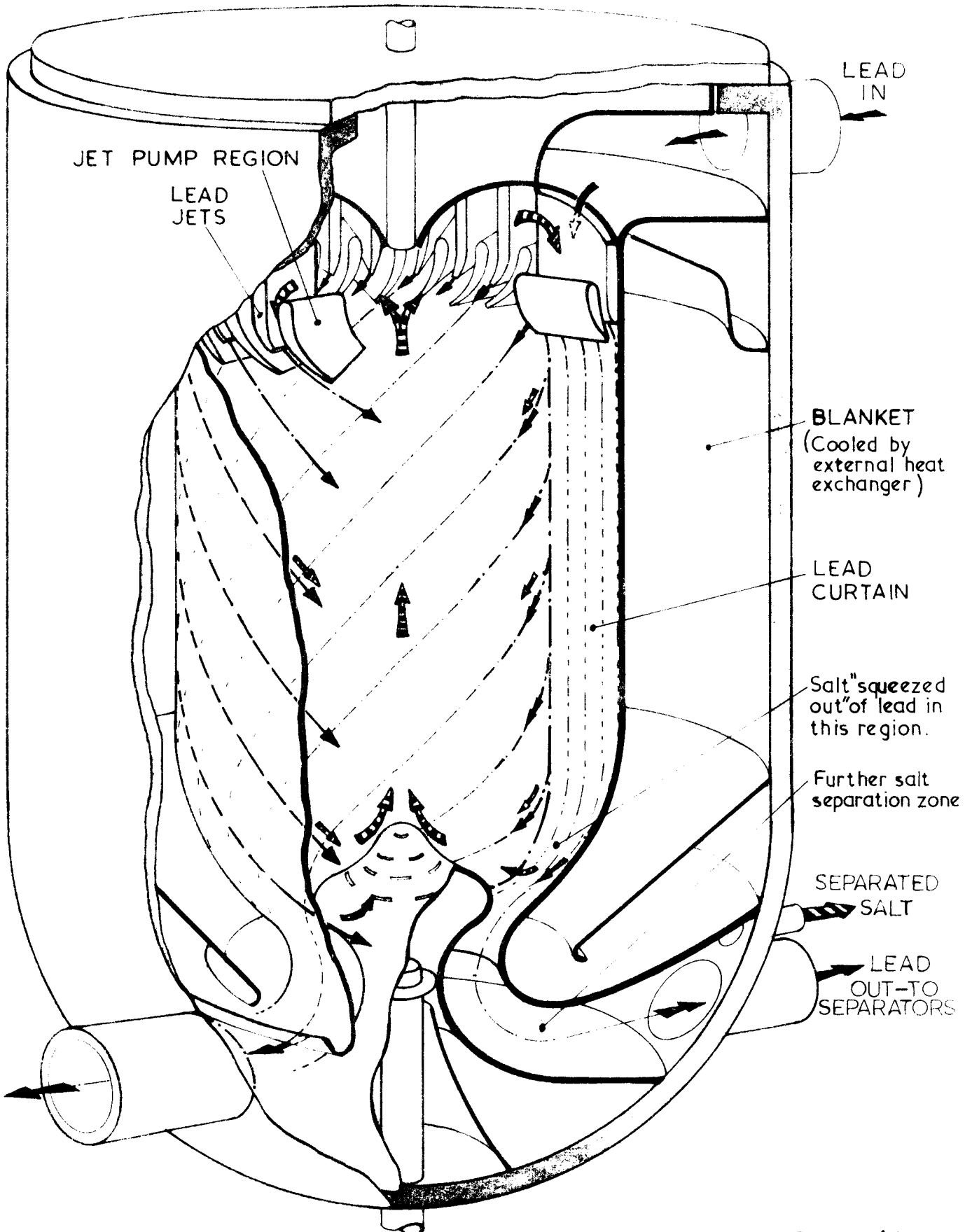

SIMPLIFIED DIAGRAM OF DIRECT SYSTEM
SHOWING LEAD CURTAIN AND POLOIDAL FLOW

FIG. 4b

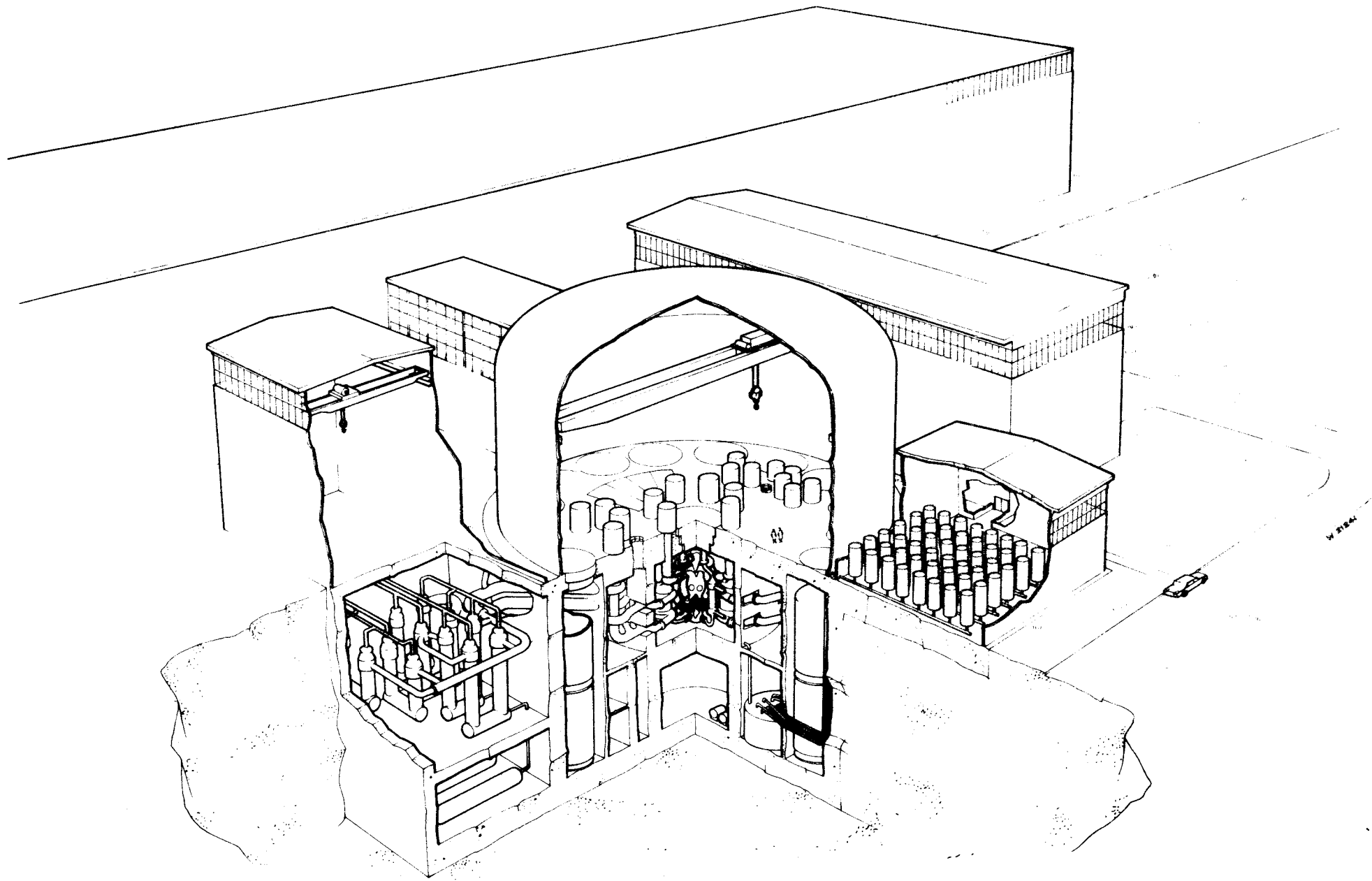

GENERAL VIEW OF 2,500 MW_e MSFR (INDIRECT SYSTEM — BASED ON DESIGN 1)

FIG. 5

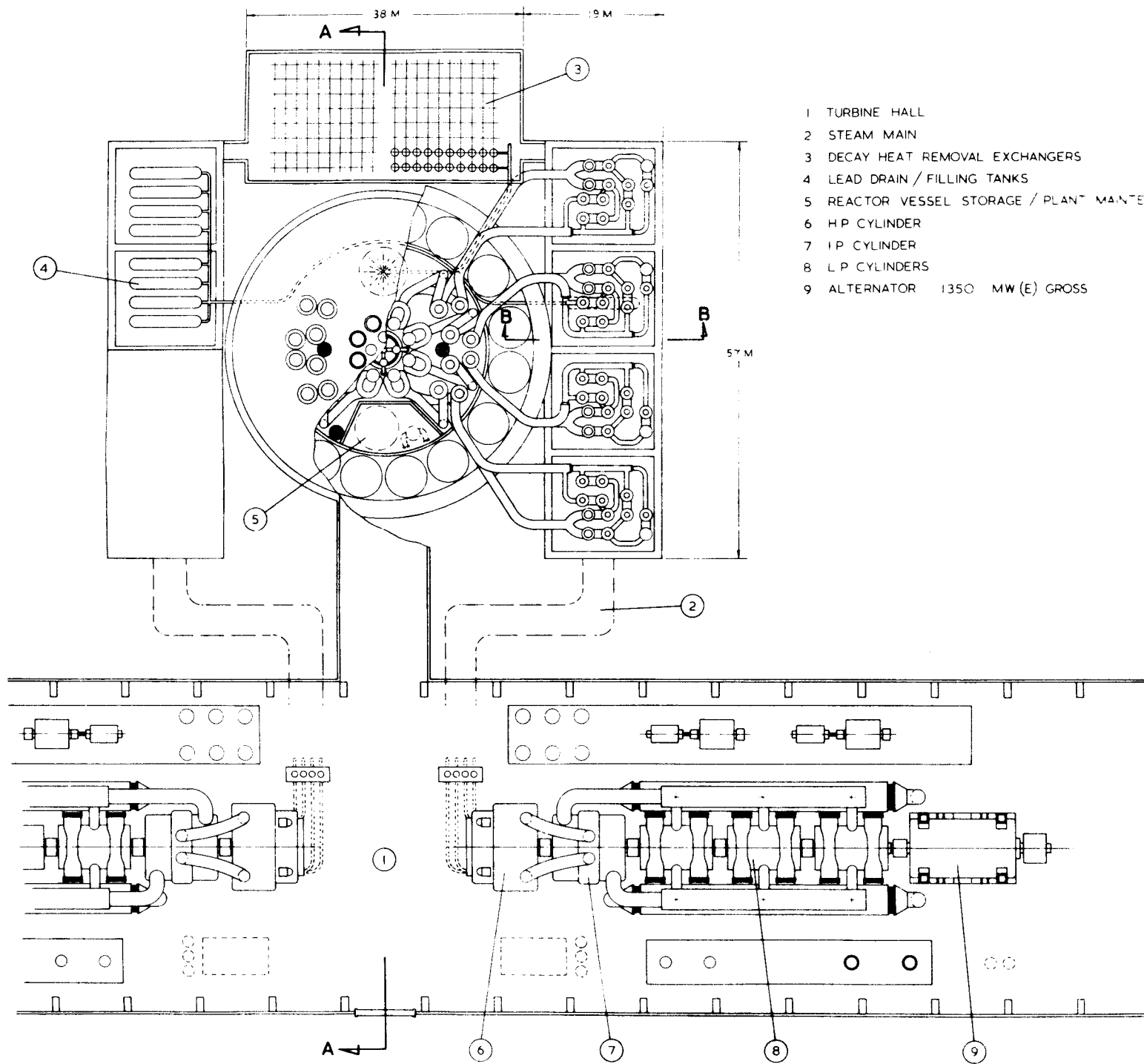

- 1 TURBINE HALL
- 2 STEAM MAIN
- 3 DECAY HEAT REMOVAL EXCHANGERS
- 4 LEAD DRAIN / FILLING TANKS
- 5 REACTOR VESSEL STORAGE / PLANT MAINTENANCE CHAMBER
- 6 HP CYLINDER
- 7 IP CYLINDER
- 8 LP CYLINDERS
- 9 ALTERNATOR 1350 MW (E) GROSS

M.S.F.R.
 BUILDING LAYOUT
 (INDIRECT SYSTEM-BASED
 ON DESIGN 1)

0 M 10 M 20 M
 SCALE

FIG. 6

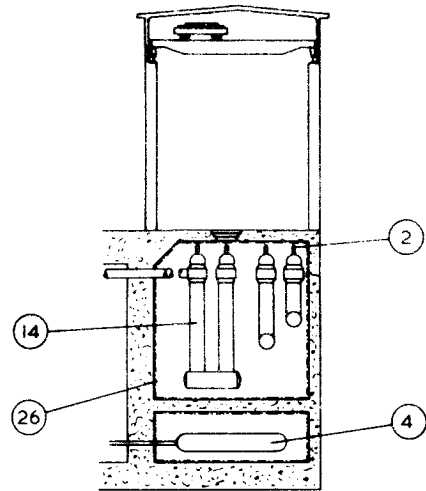

SECTION B:B

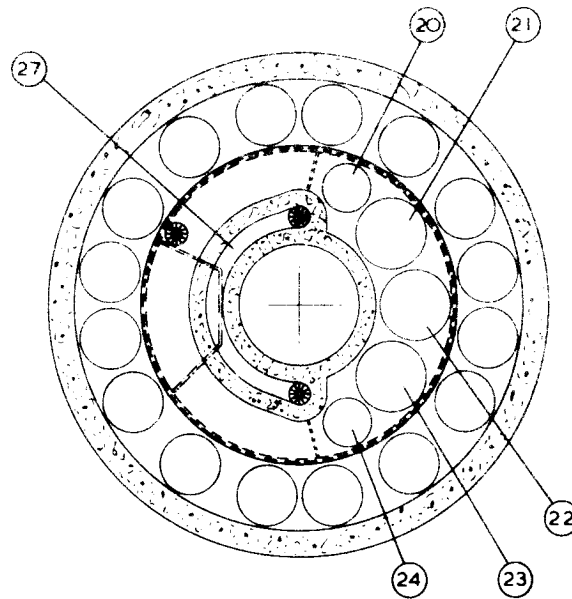

SECTION C:C

- 10 REACTOR VESSEL
- 11 BLANKET COOLER
- 12 INTERMEDIATE HEAT EXCHANGER I.H.X.
- 13 DELAY BEDS
- 14 STEAM GENERATORS
- 15 CLEAN-UP PLANT ROOM
- 16 BLANKET COOLING PUMPS
- 17 FUEL SALT PUMPS
- 18 I.H.X. LEAD CIRCULATION PUMPS
- 19 STEAM GENERATOR LEAD CIRCULATION PUMPS
- 20 FUEL STORE FOR POWER TRIMMING
- 21 CORE FILL/DRAIN & PART MAIN DUMP SYSTEM
- 22 (AUX CORE & BLANKET DRAIN TANK
PRIMARY DECAY TANK
- 23 BLANKET FILL/DRAIN & PART MAIN DUMP SYSTEM
- 24 SECONDARY DECAY TANK
- 25 TEMP INSULATING PARTITION WALLS & FLOORING
- 26 TEMPERATURE INSULATION
- 27 ACCESS CORRIDOR
- 28 CONTROL ROOM

SEE FIG 4b FOR ITEMS 1-9

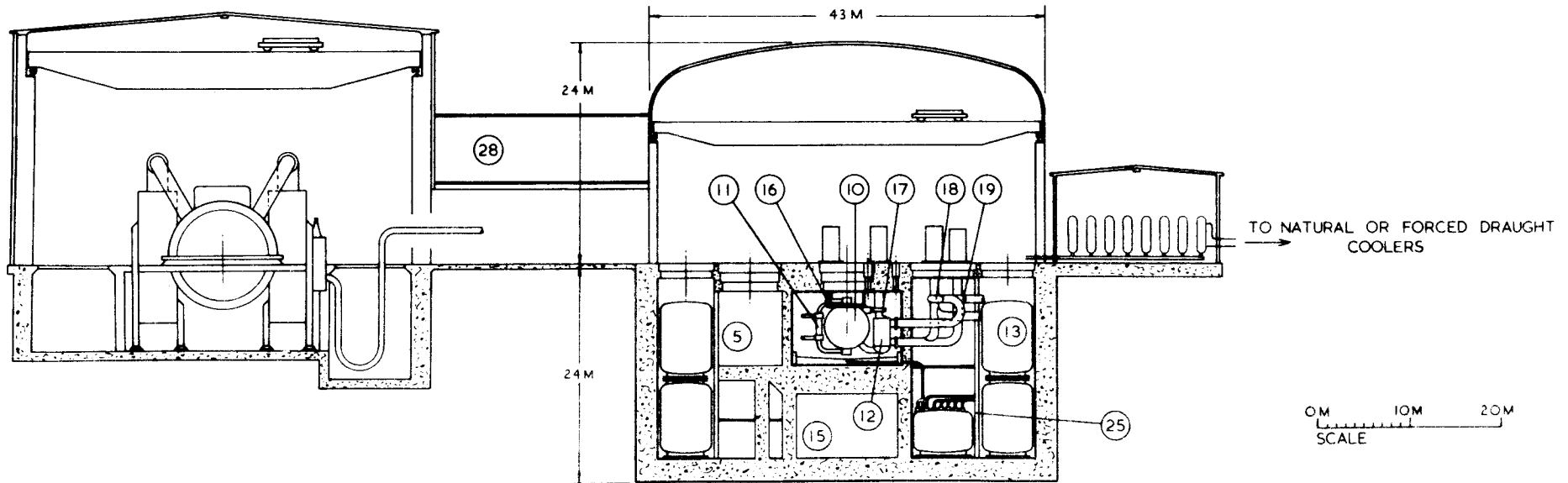

SECTION A:A

M.S.F.R. BUILDING LAYOUT (INDIRECT SYSTEM-BASED ON DESIGN I)

FIG 7

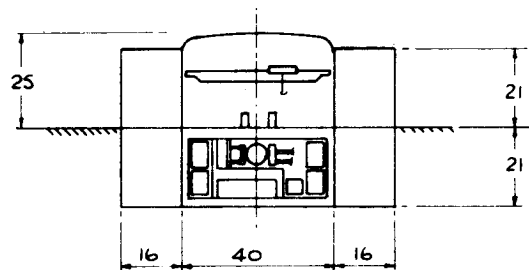

M.S.F.R.
2500 MWe

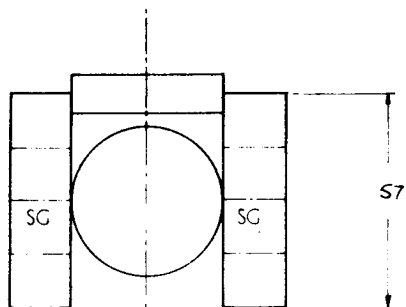

SG - STEAM GENERATING PLANT

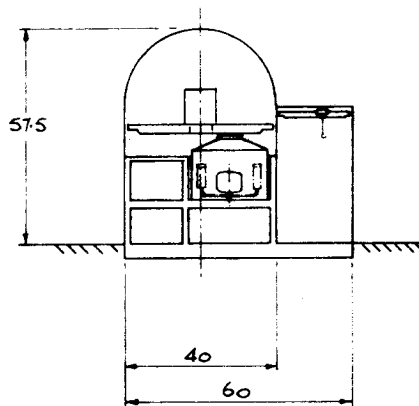

M.S.B.R.
1000 MWe

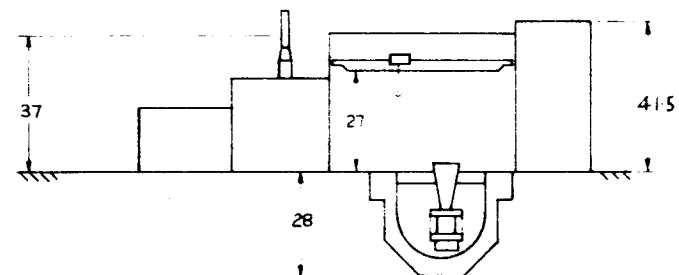
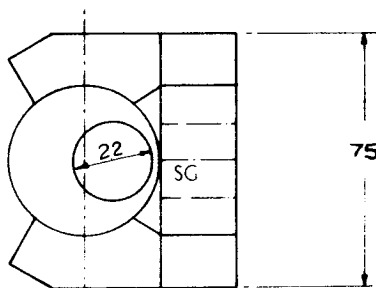

C.F.R.
2 x 1300 MWe

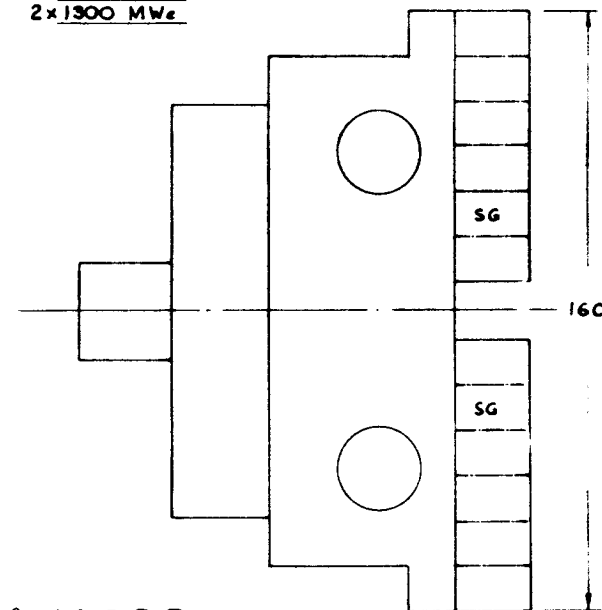

SIZE COMPARISON OF M.S.F.R. WITH C.F.R. & M.S.B.R.

SCALE 1/1000 0 50 METRES

FIG. 8

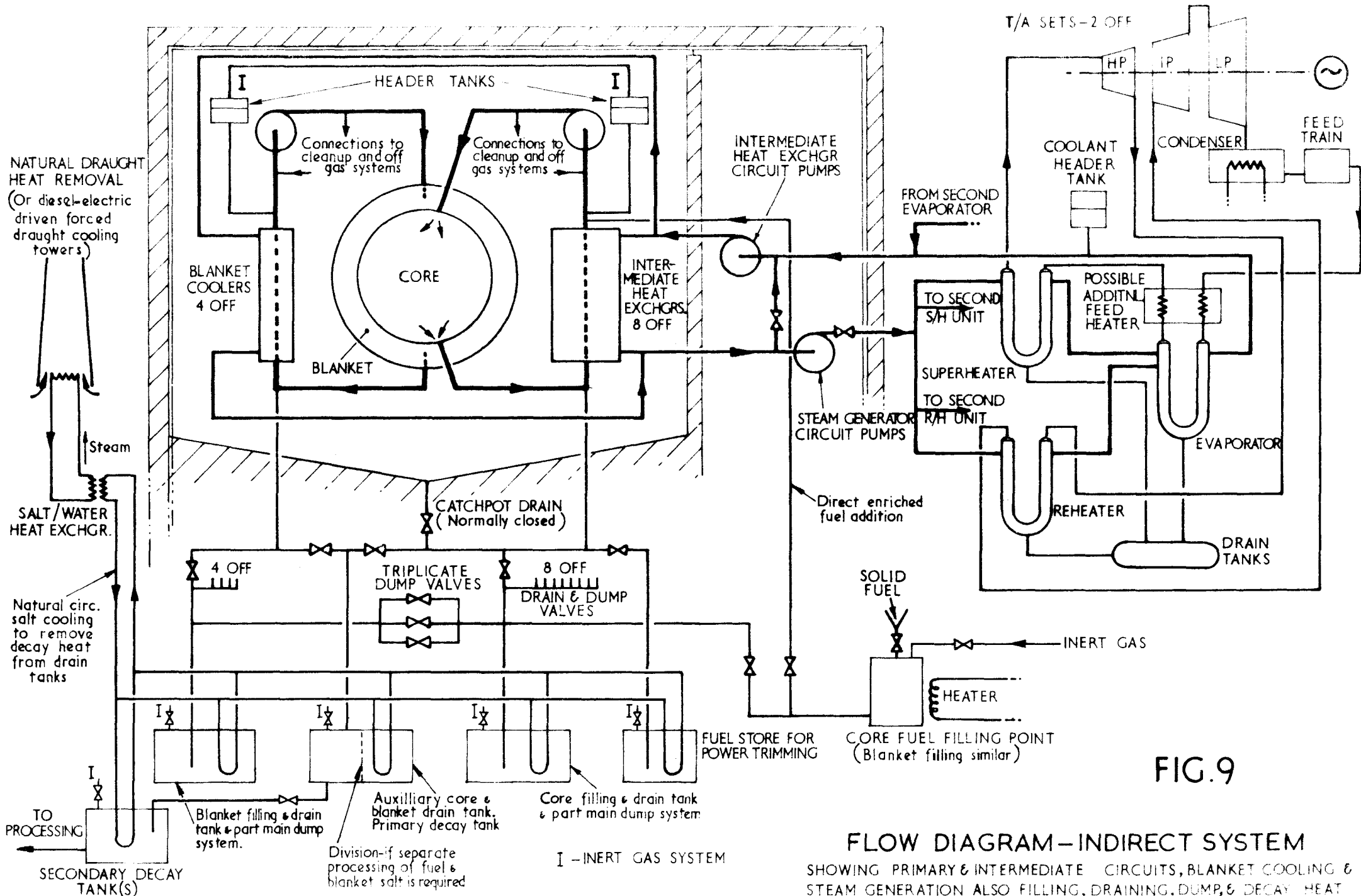
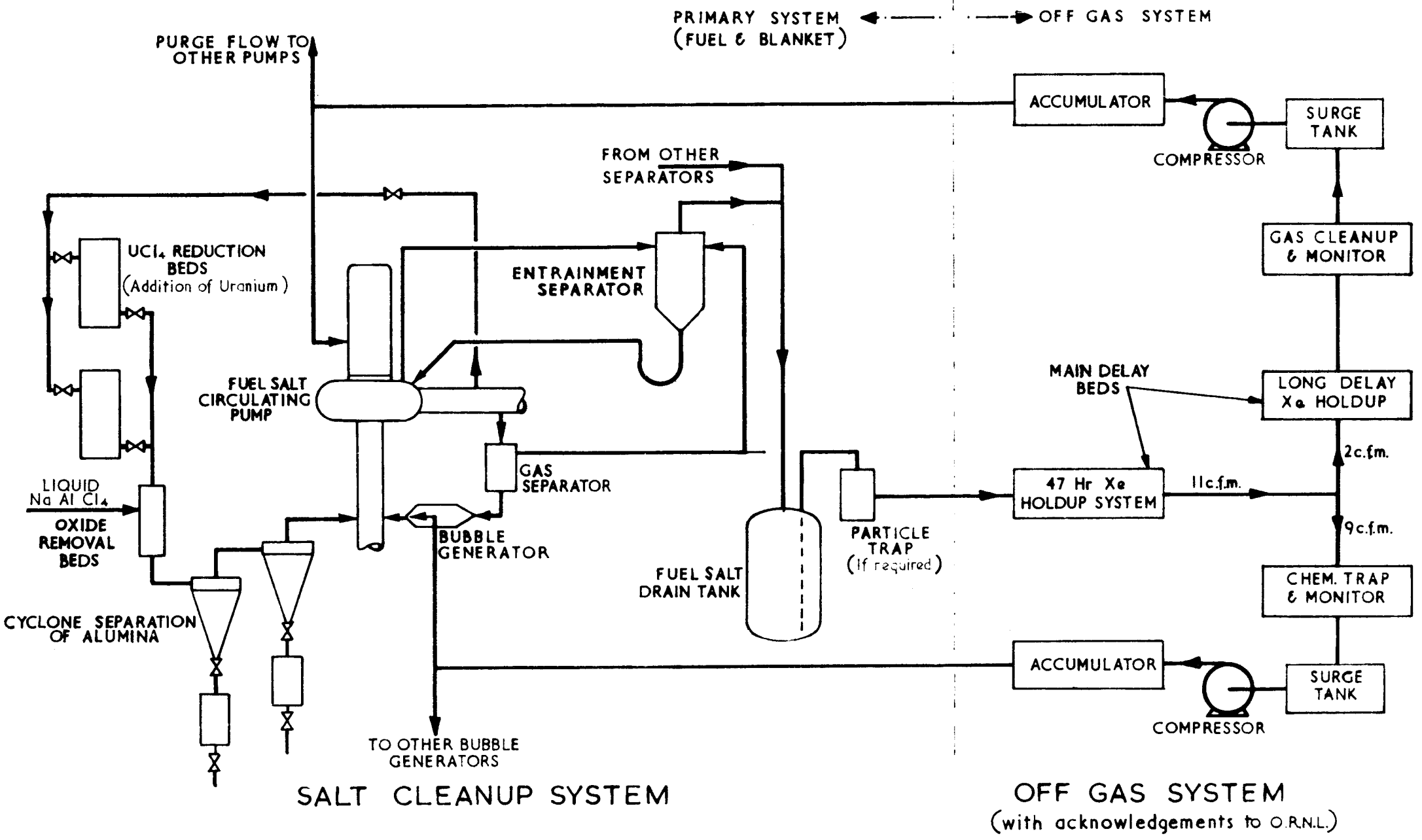

FIG. 9

FLOW DIAGRAM—INDIRECT SYSTEM

SHOWING PRIMARY & INTERMEDIATE CIRCUITS, BLANKET COOLING & STEAM GENERATION ALSO FILLING, DRAINING, DUMP, & DECAY HEAT REMOVAL SYSTEMS.

I — INERT GAS SYSTEM



FLOW DIAGRAM— FUEL & BLANKET SALT CLEANUP & OFFGASSING FIG.10

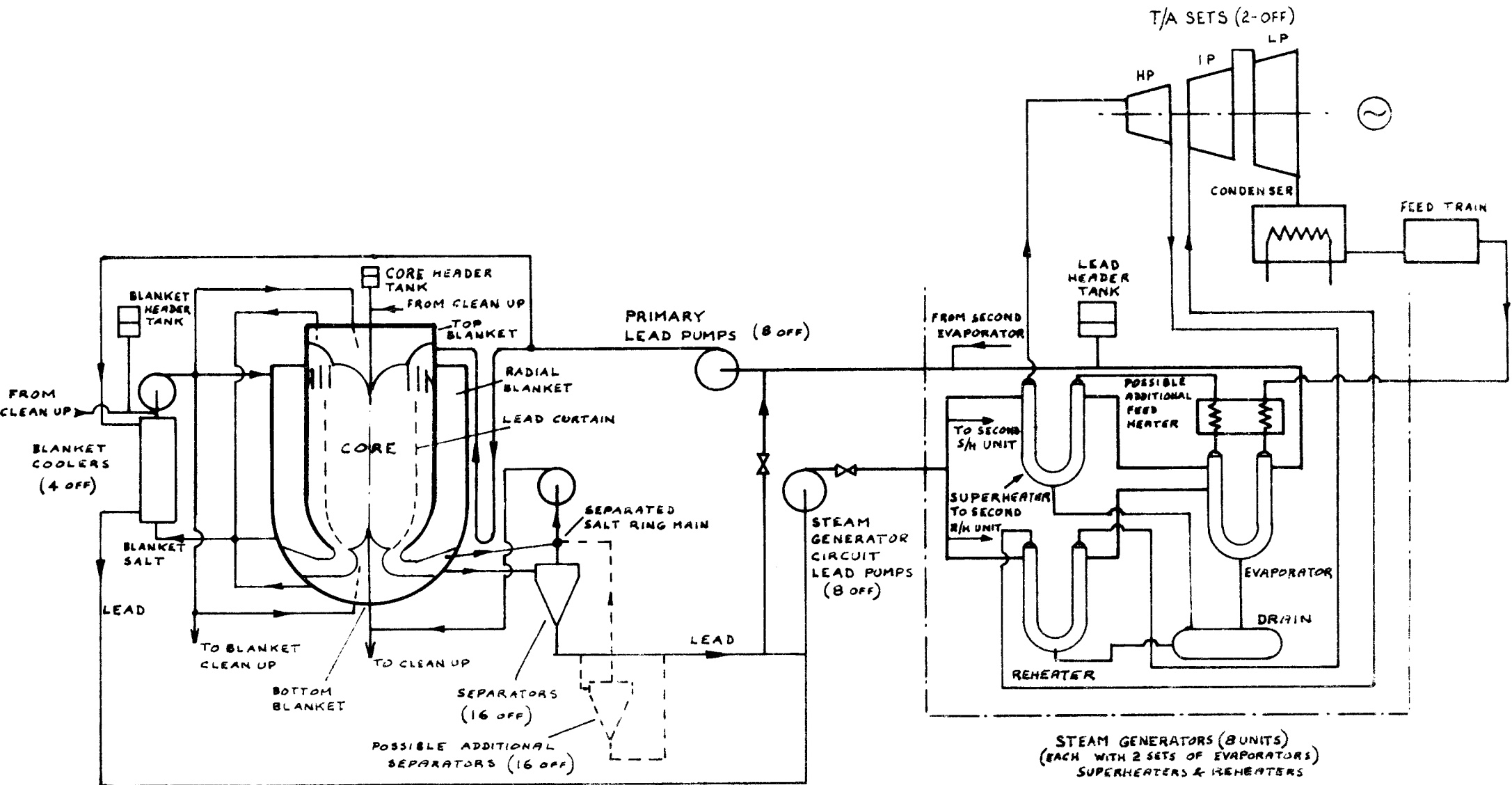
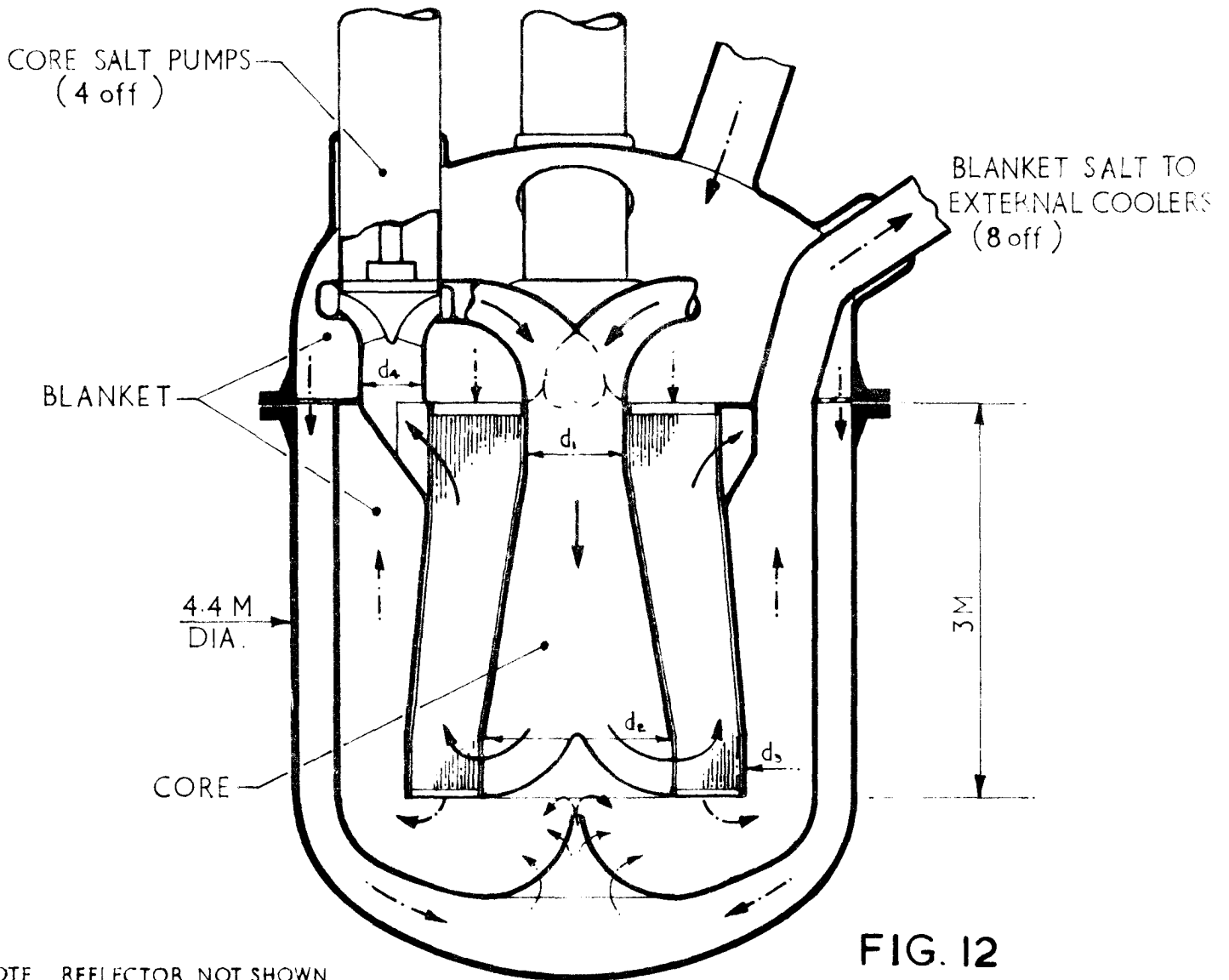
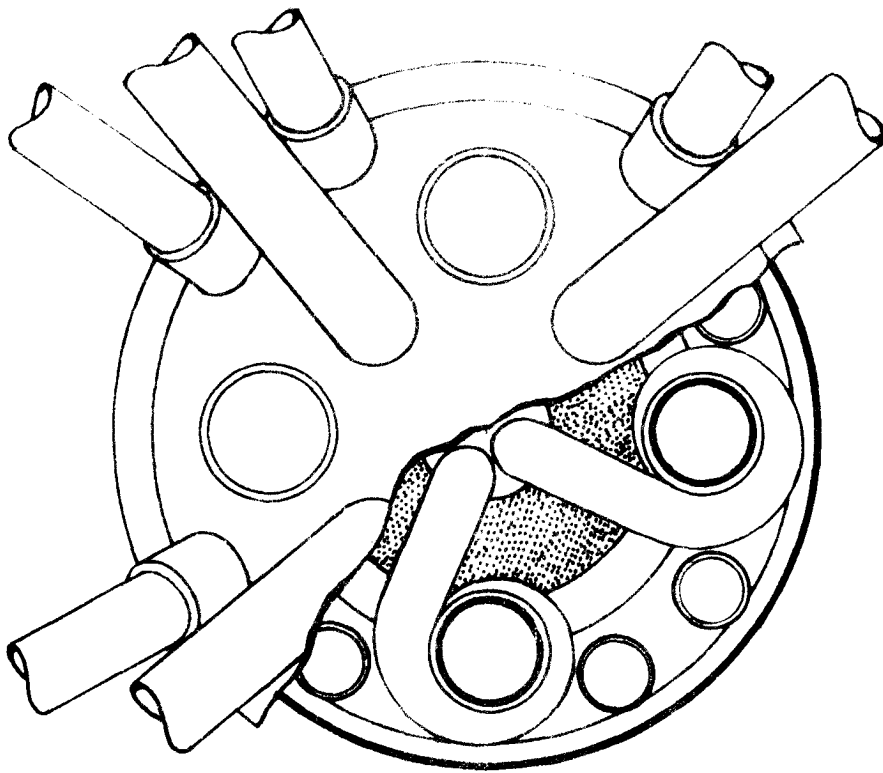

FIG. 11

FLOW DIAGRAM — DIRECT SYSTEM. PRIMARY & INTERMEDIATE CIRCUITS
BLANKET COOLING & STEAM GENERATION.



NOTE. REFLECTOR NOT SHOWN



Note: Dimensions relate to tube pitch/diameter ≈ 1.4

FIG. 12

INTERNALLY COOLED
M.S.F.R

6000 MW Th

NOT FOR PUBLICATION (COMMERCIAL)

DISTRIBUTION

WINFRITH

Mr H Cartwright		A32
Dr J E R Holmes		A32
Mr J Smith	(12)	A32
Mr C P Gratton		A32
Mr D M Harris		B40
Mr W C May		A32
Mr J E C Mills		A32
Mr G L Shires		B40
Mr W E Simmons	(8)	A32
Mr R J Symes		A32

CULHAM

Dr R S Pease
Mr J H Adlam
Mr T Dullforce
Mr R S Peckover
Dr J A Reynolds
Mr R T Whipple
Mr J D Jukes
Dr K V Roberts

DOUNREAY

Dr R H Allardice

HARWELL

Dr R C Asher
Dr J K Dawson
Mr B L Eyre
Mr B R Harder
Mr F Hudswell
Dr C F Knights
Dr B A S Lister
Mr A E Little
Dr G Long
Dr H P C McKay
Mr S F Pugh
Mr J C Ralph
Mr D Scargill
Dr P M S Jones
Mr H Killingback
Mr J Richards

PAU 156
PAU 156
PAU 156

RISLEY

Dr T N Marsham
Mr C Beveridge

NOT FOR PUBLICATION (COMMERCIAL)

RISLEY (Continued)

Mr A A Farmer
Mr C E Iliffe
Mr N H McLaren
Mr J Stephenson
Dr R D Smith

BNFL RISLEY

Mr H A Hughes
Mr D S Briggs

LONDON OFFICE

Mr R L R Nicholson
Mr L G Brookes
Mr S T C C Hood

CEGB

Mr P Gibbs
Dr J K Wright
Dr P Jones

CEGB Cheltenham
CEGB Courtenay House
Berkley Laboratory

SSEB

Dr I Preston

Inverlair Avenue

TNPG

Mr R D Vaughan