

Disposition Options for Uranium-233

C. W. Forsberg, E. C. Beahm, L. R. Dole, A. S. Icenhour, and S. N. Storch

Chemical Technology Division
Oak Ridge National Laboratory*
Oak Ridge, Tennessee 37831-6180
Tel: (423) 574-6783
Fax: (423) 574-9512
E-mail: forsbergcw@ornl.gov

L. C. Lewis

Idaho National Engineering and Environmental Laboratory
Idaho Falls, Idaho 83415
Tel: (208) 526-3295
Fax: (208) 526-4902
E-mail: llewis@inel.gov

E. L. Youngblood

Advanced Integrated Management Services, Inc.
Oak Ridge, Tennessee 37830

June 1, 1999

*Managed by Lockheed Martin Energy Research Corp., under contract DE-AC05-96OR22464 for the U.S. Department of Energy.

CONTENTS

LIST OF FIGURES	ix
LIST OF TABLES	xi
ACRONYMS AND ABBREVIATIONS	xiii
PREFACE	xvii
EXECUTIVE SUMMARY	xix
ABSTRACT	xxxi
1. INTRODUCTION	1
1.1 OBJECTIVES	1
1.2 SELECTION OF STORAGE AND DISPOSAL OPTIONS	1
1.3 CAVEATS	1
1.4 SPECIAL ISSUES ASSOCIATED WITH ²³³ U	2
1.5 REPORT ORGANIZATION	2
2. CHARACTERISTICS AND INVENTORIES OF ²³³ U	3
2.1 CHARACTERISTICS	3
2.1.1 Chemical	3
2.1.2 Radiological	3
2.1.3 Nuclear	8
2.1.4 Institutional	8
2.1.4.1 Safeguards	8
2.1.4.2 Waste Management	9
2.2 INVENTORIES OF ²³³ U	10
2.2.1 Inventories	10
2.2.1.1 Clean ²³³ U	10
2.2.1.2 CEUSP ²³³ U	10
2.2.1.3 LWBR ²³³ U	16
2.2.2 Quality	16

CONTENTS (continued)

3. GOALS AND CONSTRAINTS	17
3.1 GOALS	17
3.2 STORAGE OPTIONS AND CONSTRAINTS	18
3.2.1 Storage Policy Options	18
3.2.1.1 Store As-Is	18
3.2.1.2 Isotopically Dilute to Non-Weapons-Usable ²³³ U for Future Use	18
3.2.1.3 Isotopically Dilute to Critically Safe ²³³ U	20
3.2.2 Impact of Potential Uses of ²³³ U on Storage and Disposition Options ...	20
3.2.2.1 Medical Applications	20
3.2.2.2 Low-Mass Reactors for Deep-Space and Other Special-Purpose Missions	24
3.2.2.3 Analytical Tracer	26
3.2.2.4 Nuclear Weapons Research	26
3.2.2.5 Reactor Fuel Cycle Research	26
3.3 DISPOSAL OPTIONS AND CONSTRAINTS	27
3.3.1 Criticality Control	27
3.3.2 Waste Definitions and Legal Constraints	28
3.3.3 Interactions Between and Among Disposal Site Criticality Control, Waste Volumes, and Costs	30
3.3.4 Economics and Schedules	32
3.3.5 Storage for Future Disposal	34
4. TECHNICAL DESCRIPTIONS OF OPTIONS	35
4.1 CONVERT ²³³ U TO HLW GLASS WITH DU FROM HLW SLUDGE (DISPOSAL)	35
4.1.1 General Description	35
4.1.2 Suboptions	38
4.1.3 Current SRS Baseline Option	39
4.1.4 Issues	40
4.2 CONVERT ²³³ U AND DU TO A URANIUM-ALUMINUM ALLOY (STORAGE AND DISPOSAL)	41
4.2.1 SNF and ²³³ U: Similar Materials and Similar Goals	41
4.2.2 Melt-Dilute Technology	44

CONTENTS (continued)

4.2.3	Uranium-233: Specific Uranium-Aluminum Alloy Issues and Options . . .	47
4.2.3.1	Other Chemical Species	47
4.2.3.2	Direct Processing of CEUSP ²³³ U Containers	48
4.2.3.3	Product Volumes	48
4.2.3.4	Option Variants	48
4.2.4	Conclusions	49
4.3	AQUEOUS NITRATE BLENDING OF ²³³ U WITH DU (STORAGE AND DISPOSAL)	49
4.3.1	Characteristics of Aqueous Option	49
4.3.2	Process Description	52
4.4	FUSION-MELT BLENDING (STORAGE AND DISPOSAL)	55
4.4.1	Process Descriptions	60
4.4.1.1	Glass Fusion Melt Process Description	60
4.4.1.2	Boron-Oxide Fusion Melt	61
4.4.2	Uncertainties	63
4.4.3	Conclusions	63
4.5	DRY GRINDING, BLENDING, AND SINTERING (STORAGE AND DISPOSAL)	63
4.5.1	Process Description	66
4.5.2	Variant Isotopic Mixing Methods with Dry Blending	67
4.5.2.1	Dry Blending Only	68
4.5.2.2	Dry Blending and Consolidation	68
4.5.2.3	Dry Blending with High-Temperature Sintering	69
4.5.3	Safety Issues with Dry-Blend Options	69
4.5.4	Mechanisms of Isotopic Dilution with High-Temperature Sintering and the Implications on Process Design	70
4.5.5	Conclusions	74
4.6	CHEMICAL DILUTION: WASTE THRESHOLD (DISPOSAL)	74
4.6.1	Definition of Waste Threshold	77
4.6.2	Disposition Options	81
4.6.2.1	Convert to Waste: Process with CH TRUW	81
4.6.2.2	Convert to Exception Case Material: Stand-Alone Disposal	84
4.6.3	Special Issues with Waste Threshold Options	85

CONTENTS (continued)

4.7	CAN-IN-CANISTER (DISPOSAL)	85
4.8	RH TRUW PROCESSING (DISPOSAL)	90
4.8.1	ORNL	91
4.8.2	Hanford	91
4.9	CH TRUW PROCESSING (DISPOSAL)	94
4.10	LWR FRESH FUEL (DISPOSAL)	97
4.10.1	General Description	97
4.10.2	Past Experience	100
4.10.3	Conversion of Off-Specification HEU and ²³³ U to LWR Fuel	100
4.10.3.1	Neutronics	101
4.10.3.2	Alpha Activity	104
4.10.3.3	Gamma Activity	104
4.10.4	Conclusions	105
4.11	DEEP BOREHOLE (DISPOSAL)	105
4.11.1	General Description	107
4.11.2	Waste Form and Site Characteristics	107
4.11.3	Deep-Borehole Alternative Applications	109
4.11.4	Issues	109
4.11.5	Conclusions	112
4.12	GREATER CONFINEMENT DISPOSAL (GCD) (DISPOSAL)	112
4.13	SPACE (DISPOSAL)	116
4.13.1	General Description	116
4.13.2	Waste Form Characteristics	116
4.13.3	Space Disposal Options and Destinations	119
4.13.4	Issues	119
4.13.5	Conclusions	121
4.14	SUBSEABED (DISPOSAL)	121
4.14.1	Engineering Description	123
4.14.2	Performance Capabilities	123
4.14.2.1	Predictability	126
4.14.2.2	Intrinsic Isolation	126
4.14.2.3	Independent Isolation Mechanisms	127
4.14.3	Institutional Considerations	128
4.14.4	Issues	128

CONTENTS (continued)

4.15	DISPOSAL AS SNF (DISPOSAL)	129
4.16	SHALLOW-LAND BURIAL (DISPOSAL)	132
4.17	ELECTROMETALLURGICAL PROCESSING (STORAGE AND DISPOSAL)	134
5.	CONCLUSIONS	139
5.1	SPECIAL CHARACTERISTICS OF ^{233}U	139
5.2	STORAGE AND PROCESSING OPTIONS	139
5.3	DISPOSAL OPTIONS	140
6.	REFERENCES	143
Appendix A	RADIATION LEVELS FROM ^{233}U	A-1
Appendix B	RECOVERY OF ^{229}Th FROM ^{233}U FOR MEDICAL USE	B-1
Appendix C	RECOVERY OF URANIUM FROM CEUSP CANS	C-1
Appendix D	CURRENT TECHNICAL CONSTRAINTS FOR WIPP	D-1

LIST OF FIGURES

Fig. 2.1	Different fissile materials require different handling procedures	5
Fig. 2.2	Gamma exposure for 1 kg of ²³³ U with 100 ppm of ²³² U	7
Fig. 2.3	United States inventory of separated ²³³ U	11
Fig. 2.4	Uranium-233 inventory is currently stored in different containers	13
Fig. 2.5	Chemical composition of the ²³³ U inventory	14
Fig. 3.1	Uranium-233 storage options	19
Fig. 3.2	Potential uses for ²³³ U	21
Fig. 3.3	Flowsheet for ²¹³ Bi production for treatment of cancer	23
Fig. 3.4	Recoverable ²²⁹ Th from the U.S. ²³³ U inventory	25
Fig. 3.5	Technical WIPP WAC constraints	31
Fig. 3.6	Impact of criticality control strategy on waste volumes to WIPP-type disposal site	33
Fig. 4.1	Conversion of surplus ²³³ U and HLW (containing DU) to HLW glass	37
Fig. 4.2	Isotopic dilution of ²³³ U with DU in a uranium-aluminum alloy for long-term storage or disposal	43
Fig. 4.3	Uranium-aluminum phase diagram	45
Fig. 4.4	Aqueous processing option for ²³³ U long-term storage or disposal	51
Fig. 4.5	Isotopic dilution by the aqueous-nitrate-blending process	53
Fig. 4.6	Borate-fusion melt for ²³³ U long-term storage or disposal	57
Fig. 4.7	Glass-fusion melt (alkali glass) option for disposition of ²³³ U	59
Fig. 4.8	Simple dry-blend processing for ²³³ U long-term storage or disposal options	65
Fig. 4.9	Self-diffusion of uranium in uranium oxide	72
Fig. 4.10	Chemical waste threshold disposition option for ²³³ U in a WIPP-type facility	76
Fig. 4.11	Definition of ²³³ U-containing materials	79
Fig. 4.12	Chemical waste threshold ²³³ U disposition option: Coprocessing with CH TRUW	82
Fig. 4.13	Can-in-canister ²³³ U disposition option	88
Fig. 4.14	Can-in-canister for disposition of ²³³ U or plutonium	89
Fig. 4.15	Co-processing of liquid RH TRUW and ²³³ U for disposition in a WIPP-type repository	93
Fig. 4.16	Uranium-233 disposition by co-processing with CH TRUW	96

LIST OF FIGURES (continued)

Fig. 4.17	Conversion of ^{233}U to LWR fuel, irradiation, and disposal of the SNF in YM . . .	99
Fig. 4.18	Borehole disposal of ^{233}U	108
Fig. 4.19	Process flow diagrams for the immobilized and direct deep borehole disposition alternatives	110
Fig. 4.20	The deep borehole disposal concept for immobilized disposal of coated ceramic pellets in grout	111
Fig. 4.21	GCD options for ^{233}U	115
Fig. 4.22	Space disposal of ^{233}U	118
Fig. 4.23	Subseabed disposal options	124
Fig. 4.24	Characteristics of seabed disposal options	125
Fig. 4.25	Co-disposal of ^{233}U (defined as SNF) with HLW	130
Fig. 4.26	Disposition of ^{233}U by dilution to LLW (<100 nCi/g) with shallow-land disposal	133
Fig. 4.27	Disposition of ^{233}U by isotopic dilution with DU using the electrometallurgical process	136
Fig. B.1	Flowsheet for ^{213}Bi production for treatment of cancer	B-4
Fig. C.1	CEUSP can assembly for monolithic uranium oxide storage	C-4

LIST OF TABLES

Table ES.1	Characteristics for storage or disposal of dispositioned ^{233}U	xxii
Table 2.1	Characteristics of weapons-usable materials	4
Table 2.2	Quality of major batches of separated ^{233}U in inventory	12
Table 2.3	Inventory of ^{233}U SNF (not part of disposition program)	15
Table 3.1	Uranium-233 uses, applicable ^{233}U categories, and isotopic requirements	22
Table 3.2	Summary of WIPP WACs, as applied to ^{233}U	32
Table 4.1	Summary: Convert ^{233}U to HLW glass with DU from HLW sludge	36
Table 4.2	Summary: Uranium-aluminum melt dilute option	42
Table 4.3	Specific volume and mass of the final uranium-aluminum alloy for different products for an initial 1 kg ^{233}U	46
Table 4.4	Summary: Aqueous nitrate blending of ^{233}U with DU	50
Table 4.5	Product volume and mass per kilogram of ^{233}U for aqueous processing	54
Table 4.6	Summary: Convert ^{233}U to borate fusion melt	56
Table 4.7	Summary: Convert ^{233}U to glass by fusion melt	58
Table 4.8	Product volume and mass per kilogram of ^{233}U	60
Table 4.9	Summary: Dry grinding, blending, and sintering	64
Table 4.10	The time required for the tenfold dilution of atoms, when the mean self-diffusion distances, $\langle r \rangle$, of the uranium atoms UO_2 are 2.16 times the original particles' radii	73
Table 4.11	Summary: Chemical dilution: waste threshold	75
Table 4.12	Summary: Can-in-canister	87
Table 4.13	Summary: Coprocessing ^{233}U with RH TRUW forms	92
Table 4.14	Summary: Convert ^{233}U to CH TRUW form	95
Table 4.15	Summary: Convert ^{233}U to LWR fuel	98
Table 4.16	Composition of candidate materials for down-blending by mixing with SRS DU	102
Table 4.17	Composition of proposed blends	103
Table 4.18	Comparison of proposed blends with ASTM specifications	103
Table 4.19	Summary: Characteristics of deep borehole disposal	106
Table 4.20	Summary: GCD of ^{233}U	113
Table 4.21	Summary: Space disposal	117

LIST OF TABLES (continued)

Table 4.22	Potential forms for nuclear waste in space disposal	120
Table 4.23	Summary: Subseabed disposal	122
Table 4.24	Summary: Dispose as SNF	131
Table 4.25	Summary: Shallow-land disposal as LLW	132
Table 4.26	Summary: Electrometallurgical process	135
Table D.1	Summary of WIPP WAC as applied to ²³³ U	D-5
Table D.2	WIPP CH TRUW container and assembly weight criteria	D-7
Table D.3	Maximum number of CH TRUW containers per TRUPACT-II and authorized packaging configurations	D-8
Table D.4	Comparison of uranium isotope and ²³⁹ Pu characteristics	D-9
Table D.5a	Summary of CH TRUW acceptance criteria requirements that pertain to ²³³ U waste thresholds	D-10
Table D.5b	Summary of RH TRUW preliminary acceptance criteria requirements that pertain to ²³³ U waste thresholds	D-11
Table D.6	Maximum allowable fissile material, expressed as ²³⁹ Pu FGE for CH TRUW in the TRUPACT-II	D-12
Table D.7a	Comparison of WIPP-based nuclear criteria for various radionuclides comprising CH TRUW	D-13
Table D.7b	Comparison of WIPP-based nuclear criteria for various radionuclides comprising RH TRUW	D-14

ACRONYMS, ABBREVIATIONS, SCIENTIFIC NOTATION, AND UNITS OF MEASURE

Al	Aluminum
AMWTF	Advanced Mixed Waste Treatment Facility
ASTM	American Society for Testing and Materials
BAC	Boeing Aerospace Company
Bi	Bismuth
Cd	Cadmium
CEUSP	Consolidated Edison Uranium Solidification Program
CH	contact-handled
DNFSB	Defense Nuclear Facilities Safety Board
DOE	U.S. Department of Energy
DOT	U.S. Department of Transportation
DU	depleted uranium
DWPF	Defense Waste Processing Facility
EIS	environmental impact statement
EPA	U.S. Environmental Protection Agency
ES&H	environmental, safety, and health
FGE	fissile gram equivalent
GCD	greater confinement disposal
GTCC	greater-than-class-C
HEPA	high-efficiency particulate air
HEU	high enriched uranium
HLW	high-level waste
IAEA	International Atomic Energy Agency
ICPP	Idaho Chemical Processing Plant
INEEL	Idaho National Engineering and Environmental Laboratory
L	liter
LLNL	Lawrence Livermore National Laboratory
LEU	low-enriched uranium
LLW	low-level waste

ACRONYMS, ABBREVIATIONS, SCIENTIFIC NOTATION, AND UNITS OF MEASURE
(continued)

LWBR	light-water breeder reactor
LWR	light-water reactor
MeV	million-electron volts
MOU	Memorandum of Understanding
NA	not applicable
NASA	National Aeronautics and Space Administration
NRC	U.S. Nuclear Regulatory Commission
NTS	Nevada Test Site
NWTRB	Nuclear Waste Technical Review Board
ORNL	Oak Ridge National Laboratory
PA	performance assessment
ppm	part(s) per million
RCRA	Resource Conservation and Recovery Act
R&D	research and development
RH	remote-handled
S&S	safeguards and security
SAR	safety analysis report
SNF	spent nuclear fuel
SRS	Savannah River Site
SWB	standard waste box
t	metric ton
TDOP	ten-drum overpack
Tl	Thallium
TRU	transuranic
TRUPACT-II	Transuranic Package Transporter-II
TRUW	transuranic waste
TVA	Tennessee Valley Authority
U	Uranium
WACs	waste acceptance criteria

ACRONYMS, ABBREVIATIONS, SCIENTIFIC NOTATION, AND UNITS OF MEASURE
(continued)

WGP	weapons-grade plutonium
WIPP	Waste Isolation Pilot Plant
WP	waste package
YM	Yucca Mountain
YMR	Yucca Mountain repository
Y-12	Y-12 Plant (Oak Ridge)
²⁰⁸ Tl	Thallium-208
²³² U	Uranium-232
²³³ U	Uranium-233
²³⁵ U	Uranium-235
²³⁸ U	Uranium-238
²¹³ B	Bismuth-213

PREFACE

This report is one of several reports which maps the strategy for the future use and disposition of uranium-233 (^{233}U) and disposal of wastes containing ^{233}U . Other relevant documents from this and other programs are listed below with a brief description of the contents.

- ORNL/TM-13550—*Strategy for the Future Use and Disposition of ^{233}U : Overview*. This document is a summary of the path forward for disposition of surplus ^{233}U . It includes required activities, identifies what major programmatic decisions will be required, and describes the potential disposition options.
- ORNL/TM-13551—*Strategy for the Future Use and Disposition of ^{233}U : History, Inventories, Storage Facilities, and Potential Future Uses*. This document includes the historical uses, sources, potential uses, and current inventory of ^{233}U . The inventory includes the quantities, storage forms, and packaging of the material.
- ORNL/TM-13552—*Strategy for the Future Use and Disposition of ^{233}U : Technical Information*. This document summarizes scientific information on ^{233}U . This includes production methods, decay processes, and the material characteristics. The requirements for storage and disposal are also included.
- ORNL/TM-13524—*Isotopic Dilution Requirements for ^{233}U Criticality Safety in Processing and Disposal Facilities*. This document determines and defines how much depleted uranium (DU) must be mixed with ^{233}U to prevent the potential for nuclear criticality under all expected process and disposal facility conditions.
- ORNL/TM-13517—*Definition of Weapons Usable ^{233}U* . This document determines and defines how much DU must be mixed with ^{233}U to convert the ^{233}U into a non-weapons-usable material.
- ORNL/TM-13591—*Uranium-233 Waste Definition: Disposition Options, Safeguards, Criticality Control, and Arms Control*. This document defines what ^{233}U -containing material is waste and what ^{233}U -containing material must be treated as fissile material.
- ORNL/M-6606—*Uranium-233 Storage Alternative Trade Study: Final Report*. This document evaluates alternative long-term ^{233}U storage options and identifies the costs for each option.
- ORNL/TM-13600—*Technical Handbook of ^{233}U Material Properties, Processing, and Handling Guidelines*. This document is a reference handbook for handling and processing ^{233}U .
- ORNL/TM-13553—*Disposition Options for Uranium-233*. This document describes and characterizes alternative disposition options for ^{233}U (this report).

EXECUTIVE SUMMARY

The U.S. Department of Energy (DOE) Fissile Materials Disposition Program (MD), in support of the U.S. arms-control and nonproliferation policies, has initiated a program to disposition surplus weapons-usable fissile material by making it inaccessible and unattractive for use in nuclear weapons. Weapons-usable fissile materials include plutonium, high-enriched uranium (HEU), and uranium-233 (^{233}U). In support of this program, Oak Ridge National Laboratory led DOE's contractor efforts to identify and characterize options for the long-term storage and disposal of excess ^{233}U . Five storage and 17 disposal options were identified and are described herein.

Storage, as a type of disposition, refers to methods to isotopically dilute ^{233}U with depleted uranium (DU) to convert the ^{233}U into a non-weapons-usable form suitable for long-term storage or future use. This is functionally equivalent to down-blending of weapons-usable HEU to low-enriched uranium (LEU).

Disposal, as a type of disposition, refers to processing the ^{233}U and disposing of the material as a waste in a manner that makes the ^{233}U inaccessible and unattractive for use in nuclear weapons. Some disposal options involve the down-blending technologies necessary for storage.

ES.1 INVENTORIES AND CHARACTERISTICS OF ^{233}U

The characteristics of ^{233}U are different from those of HEU or plutonium. Consequently, the best options for the storage and disposal of ^{233}U may be different from those for HEU and plutonium. Uranium-233 has the chemical characteristics of uranium, but it is an alpha emitter like plutonium and thus, as a minimum, must be processed within an alpha containment (e.g., in a glovebox). Uranium-233 can be rendered unsuitable for weapons use by isotopically diluting it in ^{238}U to <12 wt %. It could be further diluted with ^{238}U to minimize nuclear criticality issues associated with waste disposal.

Uranium-233 has a characteristic that makes most plutonium or HEU disposition options not viable for ^{233}U . In the production of ^{233}U , some ^{232}U is produced. The ^{232}U has a decay product, thallium-208 (^{208}Tl), which decays to lead and produces high-energy, 2.6-MeV gamma rays. The concentration of ^{232}U determines the radiation shielding required to protect workers. Uranium-233, which contains very low levels [<1 part per million (ppm)] of ^{232}U , has correspondingly low levels of gamma radiation. Uranium-233 with higher concentrations of ^{232}U (greater than a few ppm) and with associated radioactive decay products requires heavy radiation shielding and remote-handling (RH) operations to protect workers from gamma radiation. Most facilities designed to process HEU or plutonium are unsuitable to process ^{233}U .

From the perspectives of long-term storage or disposal, the existing ^{233}U inventory can be divided into three major categories: (1) clean, (2) Consolidated Edison Uranium Solidification Program (CEUSP), and (3) light-water breeder reactor (LWBR) ^{233}U . The different characteristics of these materials suggests that the preferred storage or disposal option for one category may be different from that for another category of ^{233}U .

- *Clean ^{233}U .* This uranium has very few chemical impurities and is primarily in the form of oxides. There are ~340 kg of clean ^{233}U . The uranium isotopic composition is ^{233}U with variable impurity levels of ^{232}U that are measured in parts per million. The radiation levels vary widely depending upon the ^{232}U content.
- *CEUSP ^{233}U .* The CEUSP material is a single batch of material with unusual isotopic, chemical, and packaging characteristics. The CEUSP ^{233}U inventory contains ~1,040 kg of uranium in ~400 containers. The uranium isotopic composition is ~10 wt % ^{233}U , 76 wt % ^{235}U , and a complex mixture of other uranium isotopes. It contains high concentrations of ^{232}U that create a significant radiation field. The CEUSP material contains large quantities of cadmium—a Resource Conservation and Recovery Act metal—which may create some unique institutional issues. The CEUSP material was solidified in the storage containers into a monolithic mass that is physically bound to the inside walls of the stainless-steel containers.
- *LWBR ^{233}U .* LWBR ^{233}U refers to a collection of unirradiated nuclear fuel. The LWBR ^{233}U inventory contains ~350 kg of $^{233}\text{UO}_2$ which is combined with ~14,000 kg of thorium oxide (ThO_2) in the form of unirradiated high-fired ceramic reactor fuel. The uranium isotopic composition is ^{233}U with low levels of ^{232}U . The presence of the ThO_2 makes chemical processing of the ^{233}U difficult.

ES.2 CHARACTERISTICS OF STORAGE OPTIONS

The ^{233}U could be stored for future use. Potential uses include medicine, space reactors, analytical measurements, development of thorium and nonproliferation fuel cycles, and nuclear weapons. There is current interest in production of bismuth-213 (^{213}Bi) from ^{233}U for treatment of certain cancers. Bismuth-213 is a decay product of ^{233}U . No decision has been made on what material to keep and what material to discard.

For some uses, such as medical applications, the ^{233}U could be down-blended with ^{238}U to non-weapons-usable ^{233}U and remain useful. Consequently, options for down-blending ^{233}U for storage have been investigated and are described herein. No decisions have been made on what fraction of any ^{233}U that is kept should be down-blended to non-weapons-usable material.

ES.3 CHARACTERISTICS OF DISPOSAL OPTIONS

Some disposition options would transform the ^{233}U and dispose of it as waste, thus rendering it inaccessible and unattractive for use in nuclear weapons. In most of the viable options, the ^{233}U is

converted to non-weapons-usable material by isotopic dilution with DU. The material is then disposed of as a waste. Uranium-233 is an alpha emitter like plutonium; thus, the most appropriate disposal facility to use is a geological repository. There are two types of geological repositories.

- *Yucca Mountain (YM)-type repository.* The proposed YM repository is designed for spent nuclear fuel (SNF) and solidified high-level waste (HLW). These waste forms generate significant heat and are highly radioactive. To assure repository performance, any waste form sent to YM must meet a series of waste acceptance criteria (WACs) that set stringent requirements on the chemical and physical characteristics of the waste. Uranium-233 waste forms could be accepted at YM under several sets of conditions, provided that they are in acceptable chemical and physical forms.
- *Waste Isolation Pilot Plant (WIPP)-type repository.* The WIPP repository is designed for the disposal of defense transuranic waste (TRUW), which contains small quantities of transuranic elements and generate little heat. Because of the characteristics of the waste and the design of the repository, there are few requirements relating to the chemical form of the waste.

The WIPP site would be technically acceptable for disposal of ^{233}U wastes, but the WIPP enabling legislation does not authorize disposal of ^{233}U wastes at this site. However, TRUW containing ^{233}U is allowed. The expected future volumes of wastes requiring a disposal site with capabilities similar to WIPP significantly exceed the authorized WIPP capacity. The United States must ultimately expand WIPP, build other disposal sites to manage these wastes, or find other disposal options. Existing ^{233}U wastes and other wastes that require a WIPP-type disposal facility, but which can not be sent to WIPP, are packaged to meet WIPP WACs because these criteria define not only the requirements for waste acceptance at WIPP but also those for long-term storage, transportation, and disposal of such wastes at future WIPP-type facilities. For a ^{233}U disposition option that generates WIPP-type wastes, there are two suboptions: (1) send the material to WIPP after appropriate changes in laws or regulations or (2) add the material to the existing ^{233}U wastes in inventory. The volumes of ^{233}U wastes in existing storage facilities are significantly larger than the potential volumes of wastes from any ^{233}U disposition option; thus, the addition of wastes from ^{233}U disposition activities would not fundamentally alter future ^{233}U waste management operations. Storage of ^{233}U as a non-weapons-usable waste is significantly less expensive with lower accompanying risks than storing weapons-usable ^{233}U .

ES.4 STORAGE AND DISPOSAL OPTIONS

The ^{233}U storage and disposal options are shown in Table ES.1. In several cases, there are multiple variants of specific options. Some transformation processes would render the material suitable for subsequent storage or disposal. For example, aqueous processing may be used to (1) recover medical isotopes from ^{233}U , (2) down-blend ^{233}U with ^{238}U to non-weapons-usable material for long-term storage and future use, or (3) convert the ^{233}U into a form for disposal. Conversion of ^{233}U into a form for disposal usually includes down-blending the ^{233}U with ^{238}U to minimize safeguards and repository nuclear criticality issues. For each disposal option, the type of disposal site is listed.

Table ES.1. Characteristics for storage or disposal of dispositioned ²³³U

Options with variants	Storage	Type of disposal site	Technical viability			Recovery of medical isotopes ^d			Demonstrated with uranium
			Clean	CEUSP	LWBR	Clean	CEUSP	LWBR	
HLW glass	No	YM	Yes	Yes	Maybe	Yes	Yes	No	Yes
Uranium-aluminum alloy									
Stand-alone variant	Yes	WIPP	Yes	Yes	No	Yes	Yes	No	Yes
Co-process with SNF	No	YM	Yes	Yes	No	No	No	No	Yes
Aqueous	Yes	YM/WIPP	Yes	Yes	Yes	Yes	Yes	No	Yes
Fusion melt									
Borate	Yes	WIPP	Yes	Yes	Yes	Future	Future	No	Yes
Glass	No	YM	Yes	Yes	No	No	No	No	Yes
Grind, blend, and sinter	Yes	YM/WIPP	Yes	Yes	Yes	Future	Future	No	Yes
Chemical dilution	No	WIPP	Yes	Yes	Yes	No	No	No	Yes
Can-in-canister	No	YM	No	No	Yes	No	No	No	Yes
RH TRUW	No	WIPP	Yes	Yes	Yes	Yes	Yes	No	No
Contact-handled (CH) TRUW	No	WIPP	No	No	Yes	No	No	No	No
Light-water reactor (LWR) SNF	No	YM	Yes	Yes	Yes	Yes	Yes	No	Yes
Deep borehole ^b	No	Borehole	Yes	Yes	Yes	No	No	No	No
Greater confinement disposal (GCD) ^b	No	GCD	Yes	Yes	Yes	No	No	No	No
Space disposal ^b	No	Space	Yes	Yes	Yes	No	No	No	No
Subseabed ^b	No	Subseabed	Yes	Yes	Yes	No	No	No	No
Shallow-land disposal ^b	No	Shallow-land	Yes	Yes	Yes	No	No	No	Yes
Define as SNF ^b	No	YM	No	No	Yes	No	No	No	No
Electrometallurgical ^b	Yes	YM/WIPP	Yes	Yes	Yes	?	?	No	Yes

^dYes implies that the medical isotopes can be recovered during processing. *Future* implies that medical isotopes could be recovered in the future if the material is in storage.

^bFootnoted items have very-large technical and institutional uncertainties.

The technical viability of each option for each type of ^{233}U is indicated. Some options are suitable for only certain categories of ^{233}U . For example, the uranium-aluminum melt-dilute option (described below) can be used to process clean and CEUSP ^{233}U , but not LWBR ^{233}U . In this specific case, the basic chemical processes of this option do not work well with a feed containing large quantities of thorium oxide. The LWBR material contains large quantities of thorium oxide.

Table ES.1 indicates whether the option allows the recovery of medically useful isotopes from the ^{233}U . As indicated in the table, there are no current processes for practical recovery of useful isotopes from the LWBR material. Several options appear to offer practical recovery of material for production of medical isotopes from the clean and CEUSP categories of materials.

The last column defines whether there has been any experience in processing uranium with the specific technology. A brief description of these options follows.

ES.4.1 Conversion to HLW Glass (Disposal)

Uranium-233 could be disposed of by mixing the ^{233}U with existing HLW sludges containing DU and converting the mixture into HLW glass for disposal at YM. The option is technically applicable to all categories of ^{233}U in inventory. This option has several attractive features. It produces the minimum amount of waste of any option because it uses DU that is currently in the HLW tanks for isotopic dilution. The HLW glass is qualified for disposal at YM. The option would use existing or planned facilities at the Savannah River Site (SRS) or Hanford. The viability of the option for managing LWBR ^{233}U is unclear because of several technical factors. It is uncertain whether the SRS tanks have sufficient DU to address criticality issues if the entire inventory of ^{233}U was disposed of. Disposal of all material in the Hanford waste tanks is technically viable but would require potentially longer time-frames. The option allows a one-time recovery of medical isotopes. The primary uncertainty is cost.

ES.4.2 Melting ^{233}U and DU to Form a Uranium-Aluminum Alloy (Storage and Disposal)

Uranium-233 could be melted with DU metal and aluminum metal to create a non-weapons-usable, uranium-metal alloy suitable for storage or disposal. If the uranium is in oxide form, it would be converted to metal in the process. The process has one unique characteristic: the molten aluminum can dissolve uranium, aluminum, and stainless-steel storage cans. This capability is particularly useful for processing CEUSP ^{233}U because the uranium is in a monolithic form that would be difficult to remove from the storage can. The option is applicable to clean ^{233}U and CEUSP ^{233}U , but it does not appear to be suitable for processing LWBR ^{233}U because the LWBR ThO_2 is chemically stable in molten aluminum.

The process is under development at SRS for treatment of aluminum-clad HEU SNF and has been demonstrated on a small scale with uranium. If an SNF treatment facility is built using this process, the same facility (with minor modification) could be used to process ^{233}U for disposal at YM. Alternatively, a custom ^{233}U treatment facility could be built for storage of the product or for disposal of the ^{233}U as a waste in a WIPP-type facility. A dedicated furnace might allow the recovery of medically useful isotopes. The option has potentially low processing costs. However, the final product volumes—because of the added aluminum—are significantly larger than those with other options. There are technical uncertainties.

ES.4.3 Aqueous Blending (Storage and Disposal)

In the aqueous-nitrate-blending process, solid ^{233}U material would be dissolved in nitric acid to produce an aqueous, uranyl-nitrate solution, which is mixed with a uranyl-nitrate solution of DU. After mixing, the solution is solidified for storage or disposal. Several final storage or disposal form options are possible (UO_3 , UO_2 , U_3O_8 , cement, and glass). The process would be applicable to all ^{233}U in inventory. If the ^{233}U is to be disposed of as waste, it could be sent to a YM- or WIPP-type repository. This is the only process that has been used on an industrial scale, and it is the only fully demonstrated technology. It is a proven process for recovery of medically useful isotopes. Several DOE facilities, with modifications, could process all ^{233}U . The process might be more expensive than some of the other options; however, it is the only process for which risks are fully understood and cost estimates can be easily developed.

ES.4.4 Fusion-Melt Blending (Storage and Disposal)

In the fusion-melt blend process, the ^{233}U oxide would be mixed with DU oxide powder and solvent metal oxide powder and then melted in an induction furnace to produce a glasslike material. The melt crucible would also serve as the product container. The product can be stored or disposed of in a YM- or WIPP-type repository or used as a pretreatment step to ready the material for disposal in HLW tanks (Sect. ES.4.1). The process has been demonstrated with uranium, but there are technical and institutional uncertainties that could impact costs.

There are two process variants: borate-fusion melt and glass-fusion melt. The difference between the two options is that with the borate fusion melt, the solvent metal oxide would be B_2O_3 or $\text{Na}_2\text{B}_4\text{O}_7$, whereas, for the glass fusion melt, the solvent metal oxide would be a mixture of alkali metal oxides and silicon dioxide. In the borate-fusion-melt process, a borate would be chosen as the solvent metal oxide to minimize processing difficulties and maximize the uranium content of the final product. In the glass fusion-melt process, the solvent metal oxide (usually containing high concentrations of silica) would be chosen to create a high-quality, insoluble uranium product. This choice would require added processing. Both variants have been demonstrated with uranium in the laboratory. The two variants have different uses.

- *Borate-fusion melt.* The borate-fusion melt creates a product suitable for storage or disposal in a WIPP-type repository. All categories of ^{233}U can be processed. The process is potentially the lowest-cost isotopic-dilution option (simple process, low-volume product), but technical uncertainties could impact costs. The option allows for the future recovery of medical isotopes or the ^{233}U for other uses. It also might be used in combination with another disposition process (such as disposal in HLW tanks) to optimize overall economics.
- *Glass-fusion melt.* The glass-fusion melt creates a high-quality glass suitable for disposal at a YM-type repository. Clean and CEUSP ^{233}U can be processed; LWBR ^{233}U probably can not be processed because of the chemical effects of thorium on glass properties. Product volume is significantly larger than that with the borate fusion melt process. The process would not be used for storage of ^{233}U for future use because of the difficulty of recovering the uranium or medical isotopes from the glass.

ES.4.5 Grind, Blend, and Sinter (Storage and Disposal)

In the grind, blend, and sinter process, ^{233}U oxide would be mixed with DU oxide (both in fine powder form), consolidated, and sintered at high temperatures to produce a final storage or disposal form. It is applicable to all ^{233}U . The process is a simplified variant of the process used to make the thorium- or uranium-oxide reactor fuels. The ^{233}U , after processing, would be suitable for storage or disposal at a YM- or WIPP type repository. For ^{233}U sent to storage, medical isotopes could be recovered in the future. The CEUSP ^{233}U (with cadmium) would be suitable at a WIPP-type repository, but tests would be required to determine suitability for YM-type repositories due to the cadmium in this specific material.

ES.4.6 Chemical Dilution (Disposal)

Uranium-233 could be disposed of as waste if (1) sufficiently diluted in other materials and (2) certain other requirements are met. This could be accomplished by mixing ^{233}U with large quantities of TRUW or other materials and limiting the quantity of ^{233}U per waste package. There are policy questions that must be resolved. This process has the potential for becoming the low-cost disposal option for the ^{233}U .

ES.4.7 Can-in-Canister (Disposal)

Uranium-233 could be disposed of by mixing it with other oxides, converting the mixture into a ceramic form, and packaging the mixture in small cans. The cans would be placed inside an empty HLW canister, and HLW glass would be poured around the cans containing ^{233}U . This option is similar to that proposed for plutonium disposition. There are institutional advantages for using the same processes proposed for plutonium disposition or for modifying the plutonium disposition process to permit the inclusion of selected inventories of ^{233}U material as a feed stream.

The ^{233}U has higher gamma-radiation levels than does plutonium; however, the LWBR ^{233}U could probably be co-processed with the plutonium with minor modification of the plutonium immobilization facility. The thorium in the LWBR ^{233}U could replace some or all of the functions of the uranium in the final product. The clean and CEUSP ^{233}U radiation levels are too high to allow processing in the plutonium immobilization facility. Stand-alone facilities would be required to process these materials in a can-in-canister option.

ES.4.8 RH TRUW Processing (Disposal)

DOE has large quantities of RH TRUW stored on the Oak Ridge and Hanford sites. It is planned to process much of this waste into a form acceptable for disposal at WIPP. Some RH TRUW processes, such as plasma processes, can co-process ^{233}U , DU, and RH TRUW into a form acceptable for WIPP while isotopically blending the ^{233}U and DU. No decisions have been made on what processes to use. Depending upon future waste management decisions, options may exist to dispose of ^{233}U via this route.

ES.4.9 CH TRUW Processing (Disposal)

The United States is planning to build several facilities to process certain existing inventories of CH TRUW into a form acceptable for WIPP. In this option, the ^{233}U would be co-processed with CH TRUW and DU to produce a waste acceptable for disposal at WIPP. The ^{233}U would be isotopically blended with the DU. The process is applicable to ^{233}U inventories with low external radiation levels—primarily the LWBR ^{233}U . It may not be viable for ^{233}U materials with higher radiation levels, such as the CEUSP material.

If appropriate CH TRUW facilities are built, this is a low-cost option. However, three constraints determine the viability of this option.

- The option can be used to process only ^{233}U with low gamma-radiation levels. The LWBR ^{233}U material may meet this requirement. It is relatively pure ^{233}U and is mixed with 14 t of ThO_2 . Most of the remaining inventory could not be processed in such a facility.
- The CH TRUW facility must use a process that isotopically blends ^{233}U with DU. Initially, it was proposed to build a facility in Idaho with these characteristics (plasma-arc furnace). The treatment process has been changed, and the new process no longer assures isotopic blending of ^{233}U with DU. No decisions have been made on the CH TRUW processes for other sites. The viability of the option depends upon waste management decisions on how to treat CH TRUW.
- The wastes must be acceptable for WIPP. Legal uncertainties are associated with mixing ^{233}U with CH TRUW.

ES.4.10 LWR Fuel (Disposal)

The reactor option would convert the ^{233}U into LWR fuel for irradiation in power reactors. This option would allow the beneficial use of the ^{233}U and would produce an SNF which would be acceptable for disposal at YM. The ^{233}U would be blended with DU to make a LEU oxide feed for the fuel. This technology has been demonstrated on a large scale. The Shippingport reactor operated using only ^{233}U as a fuel. This option would use a disposition path similar to that used to disposition the HEU—blend the fissile material to <5 wt % as feed to a nuclear fuel fabrication plant.

This would be one of the more expensive options. The production of ^{233}U nuclear fuels would require special process facilities for uranium purification, conversion to uranium dioxide, and fabrication of nuclear fuel. No such facilities exist in the United States (facilities do exist in India). Consequently, it would require large expenditures to build such facilities. Neither existing ^{235}U or proposed plutonium fuel fabrication facilities could process ^{233}U because of the radiation fields of the U.S. ^{233}U inventory. The aqueous processing option for ^{233}U disposition, described earlier, is effectively the first step in a multistep process to make nuclear fuel, which requires the additional steps of uranium purification, fuel fabrication, and fuel irradiation. Processes such as the aqueous process would be significantly less expensive than this option.

There is one exception to the previous conclusions. There is a batch of material that contains 42.6 kg of uranium consisting of 0.8 kg of very pure ^{233}U and 38.7 kg of ^{235}U at the Y-12 plant. The low concentration of the ^{233}U , the lack of impurities in this ^{233}U , and its alloying with ^{235}U may allow disposition of this material by converting this material to LWR nuclear fuel. If this were to occur, the conversion could be done when processing off-specification HEU in a special production campaign with modifications to the process to allow processing and irradiation of this material.

ES.4.11 Borehole (Disposal)

Uranium-233 could be converted to an appropriate form and disposed of in boreholes at depths of several kilometers. The same option was investigated for disposal of plutonium. It is technically viable, but there are major institutional difficulties in siting such a disposal facility. Because of these difficulties, the option was not pursued for disposition of plutonium.

ES.4.12 GCD (Disposal)

Uranium-233 could be converted to an appropriate form and disposed of in GCD disposal facilities. A GCD facility disposes of waste at somewhat greater depths than does a shallow-land disposal facility—typically 10 to 30 m underground. No such facilities currently exist. Major institutional difficulties would probably be encountered in siting a new disposal facility. Also, it is unclear whether this option would meet current environmental requirements.

ES.4.13 Space (Disposal)

Uranium-233 could be disposed of by launching it into space or the sun or placing it into high earth or solar orbit. There are major technical, cost, institutional, and environmental, safety, and health issues associated with launching rockets with radioactive materials into space. This would not be a viable option for disposal of the small inventory of ^{233}U .

ES.4.14 Subseabed (Disposal)

Uranium-233 could be disposed of by placing it under the ocean seabed (1) in the mid-ocean or (2) under a small oceanic island. The option has received major attention in the waste management community for disposal of HLW and SNF. It has also been considered as an option to create an international SNF repository to minimize the potential for nuclear weapons proliferation. It is technically viable and may have long-term environmental advantages over most other disposal sites but a decade and large resources would be required to develop the technology. It would be a very expensive stand-alone option for disposal of the small inventory of ^{233}U .

ES.4.15 Shallow-Land Burial (Disposal)

The ^{233}U could be diluted by a factor of $\sim 100,000$ to meet the definition of low-level waste and then disposed of in shallow-land disposal facilities. These are significant legal, technical, and economic uncertainties associated with this option.

ES.4.16 Define as SNF (Disposal)

The LWBR ^{233}U could be defined as SNF and disposed of as SNF. The LWBR ^{233}U is in the chemical and mechanical form of nuclear fuel and nuclear fuel components. There are significant legal and technical uncertainties associated with this option.

ES.4.17 Electrometallurgical Processing (Storage and Disposal)

The ^{233}U could be downblended with DU using the electrometallurgical process that produces a uranium metal product. There are significant technical uncertainties. It is unclear if the metallic waste form would be acceptable for certain types of disposal sites.

ES.5 CONCLUSIONS

Storage and disposal versions of disposition options have been identified and characterized. Multiple selection criteria will be used to identify the preferred options. No storage or disposal option ranks high in all criteria; thus, the future selection of preferred option(s) will depend upon the relative importance of different criteria. Because the various categories of ^{233}U in inventory have significantly different characteristics, the option preferred for one category may be different from the preferred option(s) for other categories.

Information about the materials and potential disposition paths is sufficient to permit initial evaluation and elimination of unqualified options. DOE is using the data in this report and other information to decide what options should be further considered for ^{233}U storage and disposition. DOE report, *Summary Report of the Screening Process to Determine Reasonable Alternatives for Disposition of Uranium-233 (1999)*: DOE/MD-0012 describes this process and the results of the initial screening process. However, significant amounts of additional data must be compiled on technical performance, programmatic timing, and comparative economics to permit qualitative evaluation and ranking of the options.

ABSTRACT

The U.S. Department of Energy, in support of the U.S. arms-control and nonproliferation policies, has initiated a program to disposition surplus weapons-usable fissile materials by making them inaccessible and unattractive for use in nuclear weapons. Seventeen methods to disposition weapons-usable uranium-233 (^{233}U) were identified and characterized. Some methods isotopically dilute ^{233}U with depleted uranium to convert it to non-weapons-usable uranium. Other methods make the ^{233}U chemically or physically inaccessible.

1. INTRODUCTION

1.1 OBJECTIVES

Since the end of the cold war, the United States has been investigating options to disposition surplus fissile materials that can be used to build nuclear weapons (Forsberg and Krichinsky January 1998). *Disposition* is the process of making weapons-usable fissile materials inaccessible and unattractive for use in nuclear weapons. Fissile materials include weapons-grade plutonium (WGP), high-enriched uranium-235 (HEU), and uranium-233 (^{233}U). This report describes the disposition options (long-term storage and disposal) for ^{233}U . The descriptions include both the technical characteristics of particular options and potential barriers (including institutional) to implementation of specific disposition options.

Storage, in the context of this report, refers to (1) isotopically down-blending weapons-usable ^{233}U with ^{238}U to convert it to nonweapons-usable ^{233}U and (2) placing the material in long-term storage. Future down-blended ^{233}U could be used for certain nondefense applications or be disposed of as a waste.

Disposal refers to all of the steps necessary to permanently dispose of the ^{233}U in a way that makes the ^{233}U inaccessible and unattractive for use in nuclear weapons. Many of the same technologies could be used for storage or disposal. However, the preferred technology(ies) for storage may be different from those for disposal because the requirements for long-term storage (with potential use of down-blended ^{233}U) are different from the requirements for ultimate disposal of ^{233}U in a repository.

1.2 SELECTION OF STORAGE AND DISPOSAL OPTIONS

The U.S. Department of Energy (DOE) is using the data in this report and other information to decide what options should be further considered for ^{233}U storage and disposition. DOE report, *Summary Report of the Screening Process to Determine Reasonable Alternatives for Disposition of Uranium-233 (1999)*: DOE/MD-0012 describes this process and the results of the initial screening process.

1.3 CAVEATS

There are two important caveats.

- *No decision has been made to dispose of ^{233}U .* The option exists to continue to store some or all of the material in its current form for possible use.
- *This report makes no recommendations on the preferred disposition option(s).* However, it does describe several options and identifies issues associated with implementing specific options. The choice of option(s) will depend upon multiple economic, technical, and institutional considerations, including appropriate National Environmental Policy Act review.

1.4 SPECIAL ISSUES ASSOCIATED WITH ²³³U

The handling and disposition of ²³³U are complex because of the unique characteristics of ²³³U and several historical factors. These are summarized herein and described later in this report.

Most facilities designed to process HEU or WGP can not safely process ²³³U. Uranium-233 has the chemical properties of uranium, but it is an alpha emitter, like plutonium. Uranium-233 contains impurities that emit high-energy gamma rays. Consequently, hot-cell facilities with special off-gas systems are sometimes required.

Multiple unique institutional issues are associated with ²³³U. Usually, regulations, laws, and treaties are developed as needed. Uranium-233 is a minor fissile material; that is, the quantities of this material are small compared to those of HEU and WGP. Because ²³³U was never used in the United States on a large scale, the institutional structure that exists for HEU and WGP does not exist for ²³³U. An institutional structure will have to be created for the disposition of ²³³U.

1.5 REPORT ORGANIZATION

This report describes storage and disposition options. Section 2 summarizes ²³³U characteristics and provides inventory data required to define viable options. Section 3 defines the technical and institutional constraints that are applicable to all options. Section 4 provides detailed descriptions of the options, while Sect. 5 presents conclusions. The appendixes provide additional technical detail on specific issues associated with one or more specific option or options.

2. CHARACTERISTICS AND INVENTORIES OF ²³³U

The characteristics of ²³³U are very different from those of HEU or plutonium. Consequently, many of the storage and disposition options for HEU and plutonium are not applicable to ²³³U. Furthermore, the ²³³U inventory can be divided into three major categories where each category of material has markedly different characteristics than do other ²³³U materials in the inventory. Some storage and disposition options that are applicable to one category of material are not applicable (or may require major modifications to be applicable) to other categories of ²³³U materials. These unique characteristics and inventory properties are summarized herein.

2.1 CHARACTERISTICS

Table 2.1 shows the characteristics of ²³³U as compared to those of the other two weapons-usable materials—WGP and HEU.

2.1.1 Chemical

Uranium-233 is chemically identical to natural and enriched uranium (Bereolos April 1998). The same chemical processes used for depleted uranium (DU), natural uranium, and HEU are usually applicable to ²³³U. However, as a radionuclide, ²³³U has a higher specific radioactivity than does DU, natural uranium, or HEU. Consequently, certain radiation-induced chemical reactions occur faster in uranium containing significant quantities of ²³³U when compared to reactions involving other uranium isotopes. This phenomenon is important in certain situations such as long-term storage during which the higher radiation levels of ²³³U require that storage containers and ²³³U storage forms do not contain organics (plastics etc.) or water that degrades and forms deleterious gases at higher radiation levels.

2.1.2 Radiological

Unlike HEU, the radiological worker-protection requirements for ultrapure ²³³U are similar to those for WGP. The primary hazard from ²³³U is alpha radiation, which is also the primary health hazard from WGP. The alpha activity of ²³³U is three orders of magnitude higher than that of HEU and about one order of magnitude less than that of WGP. Consequently, the handling and containment requirements (gloveboxes etc.) for ultrapure ²³³U are similar to those for WGP (Fig. 2.1).

Table 2.1. Characteristics of weapons-usable materials

Characteristic	Fissile material		
	Plutonium	HEU	²³³ U
Production	Neutron bombardment of ²³⁸ U	Separation from natural uranium	Neutron bombardment of ²³² Th
International Atomic Energy Agency (IAEA) weapons Category I quantity (kg)	2	5	2
Isotopic dilution limit for nonweapons ^a	None	20 wt %	~12 wt % ^a
Isotopic criticality safety limit ^b	Not applicable	1 wt %	0.66 wt %
Chemical properties	Plutonium	Uranium	Uranium
Radiation			
Alpha (relative to HEU)	10 ⁴	1	10 ³
Gamma	Low	Low	Dependent upon ²³² U impurity
Containment	Glovebox	Laboratory hood	Glovebox/shielded hot cell

^aThe 12 wt % ²³³U in ²³⁸U is based on a technical study (Forsberg March 1998). However, neither U.S. nor international regulations explicitly address the required isotopic dilution of ²³³U with ²³⁸U to convert ²³³U to nonweapons-usable ²³³U.

^bIsotopic dilution of ²³³U with ²³⁸U to this limit minimizes the potential for nuclear criticality in disposal facilities.

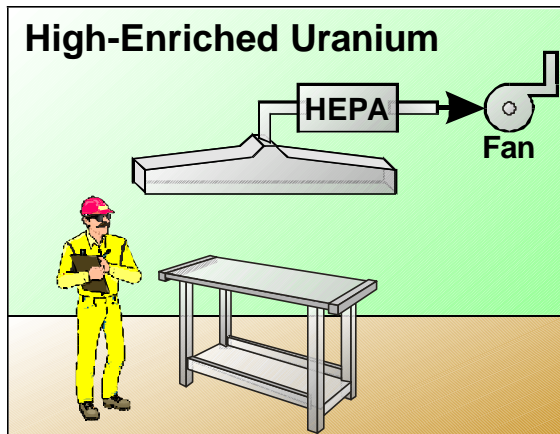

Alpha Activity (Relative) = 1
No Significant Gamma

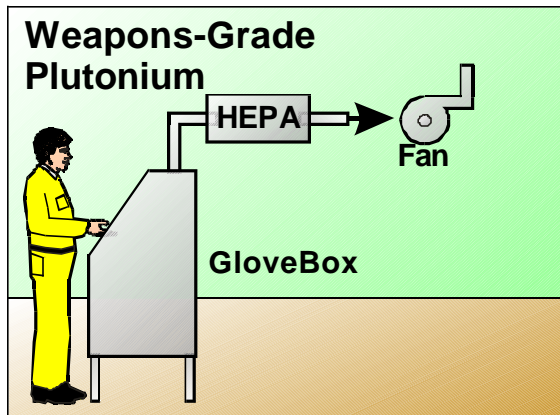

Alpha Activity (Relative) $\sim 10^4$
Soft Gamma
 - Minimal Shielding
 - Lead Gloves Acceptable

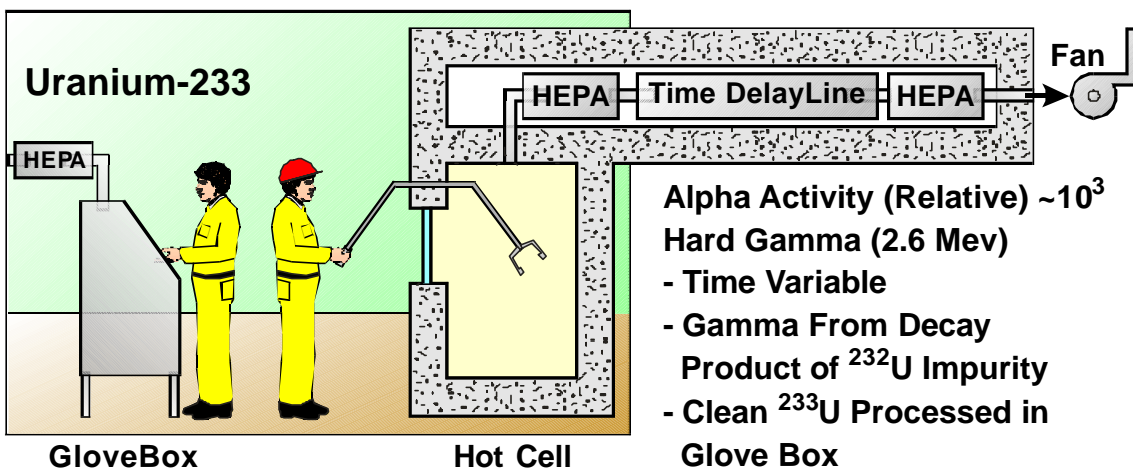

Alpha Activity (Relative) $\sim 10^3$
Hard Gamma (2.6 MeV)
 - Time Variable
 - Gamma From Decay
 Product of ^{232}U Impurity
 - Clean ^{233}U Processed in
 Glove Box

Fig.2.1. Different fissile materials require different handling procedures.

In the production of ^{233}U , some ^{232}U is produced. The concentrations of ^{232}U depend upon the specifics of the production techniques for ^{233}U . The ^{232}U has a decay product, thallium-208 (^{208}Tl), which decays to lead and produces a high-energy, 2.6-MeV gamma ray. The concentration of ^{232}U determines the radiation shielding required to protect workers. Superior-quality ^{233}U contains very low levels [~ 1 part per million (ppm)] of ^{232}U and has correspondingly low levels of gamma radiation. Low-quality ^{233}U with higher concentrations of ^{232}U (greater than a few ppm) and associated radioactive decay products requires heavy radiation shielding and remote-handling (RH) operations to protect workers from gamma radiation (Appendix A).

The ^{232}U in low-quality ^{233}U also impacts the requirements of off-gas systems for processing these materials. Uranium-232 decays through several isotopes to the noble gas ^{220}Rn . Radon-220 further decays to ^{208}Tl —the radionuclide with the 2.6-MeV gamma ray. The ^{220}Rn , as an inert gas, can pass through high-efficiency particulate air (HEPA) filters and then decay to ^{208}Tl . To prevent this from happening in a process system, the off-gas system must contain multiple traps:

- The first HEPA filter traps ^{232}U and solid decay products. Radon-220 from the process and solid materials on the HEPA filter will pass through this HEPA filter.
- Following the first filter, the system must contain charcoal beds, delay lines (~ 10 min), or other special equipment to hold the radon in the off-gas system until it decays to a solid material that can be removed from the off-gas with a second HEPA filter.
- A second HEPA filter catches the solid decay products of ^{220}Rn including ^{208}Tl .

Typical nuclear-grade off-gas systems designed for HEU or plutonium are not acceptable for ^{233}U systems with significant quantities of ^{232}U , this limitation restricts which facilities can process this material.

There is an important radiochemical characteristic of this system. If ^{233}U is chemically purified with removal of the decay products, the ^{233}U with significant concentrations of ^{232}U can be processed and converted into desired forms in gloveboxes and other enclosures without significant radiation exposure to workers. It takes time (days to weeks) for the ^{232}U radioactive decay products that emit gamma rays to build up to high enough concentrations such as to require thick radiation shielding to protect the workers. Very clean processing systems are required for this type of operation. If ^{233}U - ^{232}U contamination remains in the system, radiation levels will build up with time and can dominate the radiation field from such processes. The buildup and decay of ^{233}U , ^{232}U , and decay products are shown in Fig. 2.2 for ^{233}U with high concentrations of ^{232}U . The first set of peaks are from the buildup and subsequent decrease of the decay products of ^{232}U . The second set of peaks are from the buildup and subsequent decrease of the decay products of ^{233}U . The curve for gamma-ray generation vs time since purification of the uranium shows that, for some time after purification, the gamma-radiation doses are low.

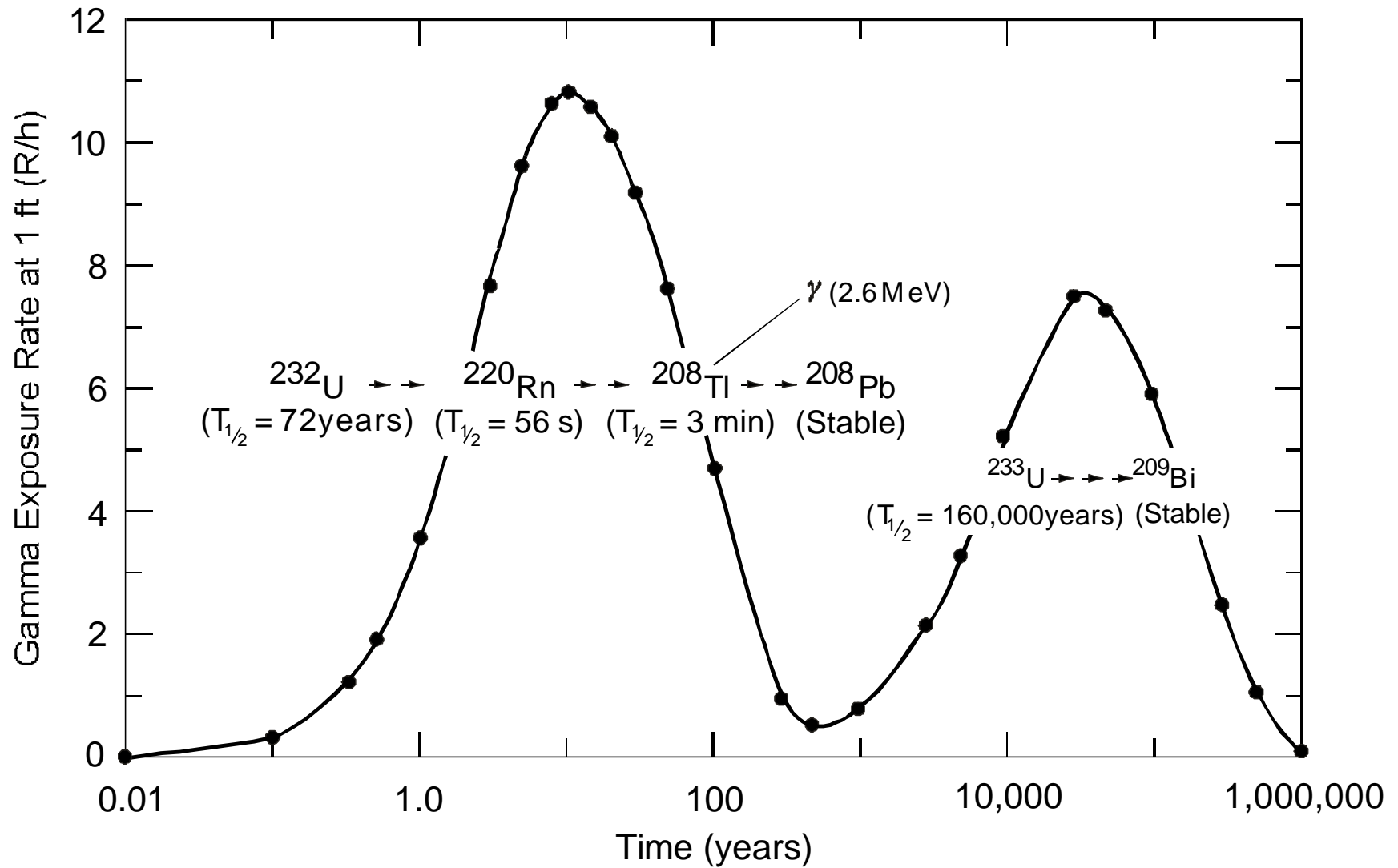

Fig.2.2.Gamma exposure for 1 kg of ^{233}U with 100 ppm of ^{232}U .

Fig. 2.2. Gamma exposure for 1 kg of ^{233}U with 100 ppm of ^{232}U .

The radiological characteristics of ^{233}U have historically determined what uranium was to be managed as ^{233}U . If a mixture of uranium contains several isotopes, the mixture is handled as ^{233}U —provided that the ^{233}U is the primary hazard. In practice, this procedure implies that uranium materials containing somewhat >1 wt % ^{233}U would be handled as ^{233}U .

2.1.3 Nuclear

The nuclear characteristics of ^{233}U are significantly different from those of WGP or HEU. The subcritical mass limit of ^{233}U is about 520 g [Oak Ridge National Laboratory (ORNL) February 18, 1994]. This is significantly less than that of ^{235}U (700 g) and slightly greater than that of ^{239}Pu (450 g). However, in certain partly-moderated systems, the critical mass of ^{233}U is less than that of plutonium. Facilities designed for HEU generally are not suitable for the storing or processing of ^{233}U . The required isotopic dilution of ^{233}U to minimize the potential of nuclear criticality (0.66 wt % when isotopically diluted with pure ^{238}U or 0.53 wt % when diluted with DU containing 0.2 wt % ^{235}U) is less than that for ^{235}U (1 wt %) (Elam November 1997).

2.1.4 Institutional

Although ^{233}U has been investigated for many applications, it has not been used on a large scale in the United States. This has several implications. United States laws, regulations (including DOE orders), and standards have been developed as needs were identified. The large large-scale production of WGP, low-enriched uranium (LEU), and HEU have led to the creation of facilities and institutional structures designed to specifically address issues associated with these materials. For example, the Waste Isolation Pilot Plant (WIPP) was designed to dispose of transuranic wastes (TRUWs) from plutonium processing operations. In addition to the facilities, legal and regulatory structures for the management of TRUW have been created. The technical characteristics of the WIPP make it suitable for disposal of ^{233}U wastes, but current law does not consider ^{233}U wastes in the WIPP enabling legislation. Thus, wastes containing only ^{233}U can not legally go to WIPP. There are many other examples. To dispose of ^{233}U materials, a set of institutional issues that are unique to ^{233}U must be addressed. The quantities of ^{233}U are sufficiently small such that it would be cost-prohibitive to build special facilities and to develop a separate institutional framework for this material. Many of the institutional structures developed for HEU and WGP can be modified and extended to ^{233}U .

2.1.4.1 Safeguards

As a fissile material, ^{233}U is similar to WGP. The IAEA (IAEA August 1993) defines Category I quantities of weapons-usable materials as 2 kg of WGP, 2 kg of ^{233}U , and 5 kg of HEU. The Category I quantity is that quantity of material requiring nuclear weapons-type security to prevent theft of the materials.

National and international safeguards requirements [DOE orders, U.S. Nuclear Regulatory Commission (NRC) regulations, IAEA agreements] for weapons-usable materials have been developed for HEU and WGP; however, the requirements are not developed fully for disposition of surplus ^{233}U . For uranium containing ^{235}U , these regulatory requirements recognize that only HEU can be made into nuclear weapons. Natural uranium, DU, and LEU do not require the safeguards and security (S&S) required of weapons-usable HEU. For disposition of surplus HEU, the U.S. policy (DOE June 1996*a*; DOE July 29, 1996) is to blend HEU with DU to make LEU for use in commercial nuclear power plants. It is universally recognized that this process eliminates the use of this material for nuclear weapons and eliminates the need for weapons-materials-type security.

For ^{233}U , the IAEA regulations (August 1993) do not recognize that mixing ^{233}U with DU will create a mixture that is unsuitable for the manufacture of nuclear weapons. It is widely recognized within the technical community that isotopic dilution with DU will eliminate ^{233}U as a weapons-usable material; however, all ^{233}U -bearing materials containing significant quantities of ^{233}U are treated as weapons-usable material. Historically, there never was any serious consideration of converting ^{233}U to a non-weapons-usable material; thus, the required regulatory structure was not established. The technical basis for converting ^{233}U to non-weapons-usable material by diluting it with ^{238}U is understood, but the regulations and other institutional agreements are not in place. Because one of the goals of the Fissile Materials Disposition Program is to reduce the risks from these materials in other countries, institutional agreements as to the level of isotopic dilution that eliminates the weapons potential of ^{233}U are required (Forsberg et al. March 1998). The isotopic purity that renders ^{233}U non-weapons-usable (<12 wt % ^{233}U in ^{238}U) is less than that for HEU (<20 wt % ^{235}U in ^{238}U).

2.1.4.2 Waste Management

In the United States, no facilities currently exist for disposing of wastes containing significant concentrations of ^{233}U . Wastes would be generated from any processing or handling operations. Historically, wastes containing ^{233}U have been managed as TRUWs (i.e., managed similarly to wastes containing plutonium) because the primary hazard—alpha radiation—is identical in both waste types; thus, the same types of disposal facilities are required. WIPP has been built to dispose of defense TRUWs. However, the enabling legislation does not allow the disposal of wastes containing only ^{233}U or wastes from nondefense activities. DOE has several thousand drums of ^{233}U -containing wastes stored at ORNL, Idaho National Engineering and Environmental Laboratory (INEEL), and Los Alamos National Laboratory. A WIPP-type facility would be suitable for ^{233}U waste disposal.

2.2 INVENTORIES OF ^{233}U

2.2.1 Inventories

From the perspectives of long-term storage and disposition options, the separated inventory can be divided into three major categories: clean, Consolidated Edison Uranium Solidification Program (CEUSP), and light-water breeder reactor (LWBR) ^{233}U . Because of technical, cost, and other factors, many options can only manage one or two of these ^{233}U categories. Figure 2.3 shows these categories where the area on top of the cylinder represents the quantity of ^{233}U and the volume represents the total volume of material (^{233}U and other materials). Table 2.2 further breaks down the 3 major categories into subcategories. More detailed inventory information is available in a companion report (Bereolos June 1998). Uranium-233 in spent nuclear fuel (SNF) and irradiated targets is not included in these numbers.

The inventory contains ~800 kg ^{233}U in ~1,800 kg of uranium in a total of 1,505 packages at multiple sites. Most of the separated ^{233}U and most of the packages are located at ORNL in the National Repository for ^{233}U . The ^{233}U is typically packaged in double containers with the inner container made of stainless steel or aluminum. Figure 2.4 shows the primary types of storage containers. Figure 2.5 shows the chemical compositions of the three categories.

In addition to the separated ^{233}U , there is a significant inventory of ^{233}U in SNF (Table 2.3). This material is shown here for completeness; but, it is not part of the disposition program. As SNF, it meets the Spent Fuel Standard.

2.2.1.1 Clean ^{233}U

The clean ^{233}U consists of five large batches of material plus many small lots. The uranium isotopic composition is ^{233}U with variable impurity levels of ^{232}U that are measured in ppm (Table 2.2). The radiation levels vary widely depending upon the ^{232}U content. This uranium is primarily in the chemical form of oxides with few chemical impurities. Most of the inventory is stored at ORNL in a variety of containers.

2.2.1.2 CEUSP ^{233}U

The CEUSP ^{233}U was created from the irradiation of a HEU-thorium fuel in the Indian Point Reactor Unit I, which is owned by the Consolidation Edison Company. The SNF was reprocessed with the ^{233}U shipped in the form of a uranium-nitrate aqueous solution to ORNL, where it was solidified for storage. Because all of this material was stored as a liquid solution in a single tank, this is a single, homogeneous batch of material. It has several unusual properties.

First, the CEUSP materials is a mixture of ~10 wt % ^{233}U , ~76 wt % ^{235}U , and other uranium isotopes. It is ^{233}U isotopically diluted with HEU.

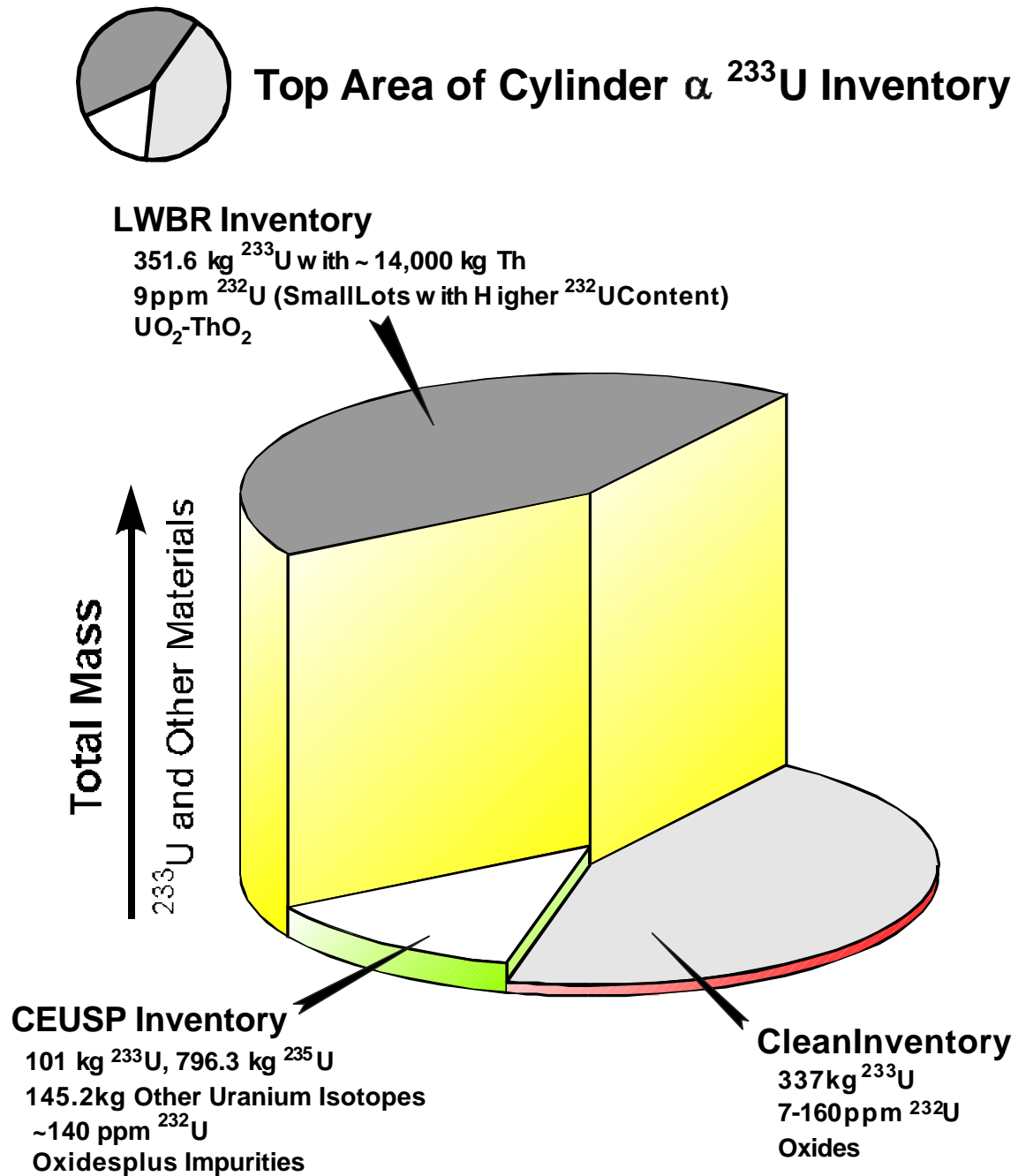

Fig. 2.3. United States inventory of separated ^{233}U .

Table 2.2. Quality of major batches of separated ^{233}U in inventory^a

Batch no.	Site	Material, packaging	Uranium isotopic composition				Measures of quality ^b	
			Total U (kg)	^{235}U (kg)	^{233}U (kg)	^{232}U (ppm) ^c	Total U (kg)/ ^{233}U (kg)	^{232}U (mg)/ ^{233}U (kg)
CEUSP								
1	ORNL	U_3O_8 monolith in >400 welded stainless steel cans (CEUSP material)	1042.6	796.3	101.1	140	10.3	1400
LWBR								
2	INEEL/Radioactive Waste Management Complex ^d	Unirradiated rods and pellets in 172 drums	35.1	0.00	34.0	21	1.03	21
3	INEEL/Idaho Chemical Processing Plant (ICPP) ^e	Unirradiated LWBR fuel with 14 t natural thorium	323.5	0.00	317.4	9	1.02	8
Clean								
4	ORNL	UO_x powder in 140 welded inner aluminum cans	67.4	0.00	61.3	165	1.1	180
5	ORNL	U_3O_8 monolith in 27 welded stainless steel cans placed in tin-plate cans	65.2	0.00	60.3	15	1.08	16
6	ORNL	UO_x powder in 174 stainless steel screw-top cans	96.6	0.00	91.3	7	1.08	7
7	ORNL	UO_x powder in 1743 welded stainless steel plates	46.2	0.00	45	7	1.03	7
8	Y-12 ^f	UO_x powder in 5 cans	42.6	38.70	0.8	6	53.2	6
9	Various	Variety of material forms, packages, and compositions	81.5	<0.1	79.6	<10	1.04	

^aThese data do not represent the entire inventory. Many small batches are not listed. Estimated total quantity of such batches is <1 kg. In addition, the table excludes ^{233}U in SNF and waste streams. Remediation actions associated with the Molten Salt Reactor Experiment may ultimately recover ~40 kg of additional ^{233}U to be added to the clean inventory.

^bA low number implies higher quality.

^cBased on the total uranium content.

^dThe Radiological Waste Management Complex at INEEL.

^eThe ICPP at INEEL.

^fThe Oak Ridge Y-12 Plant.

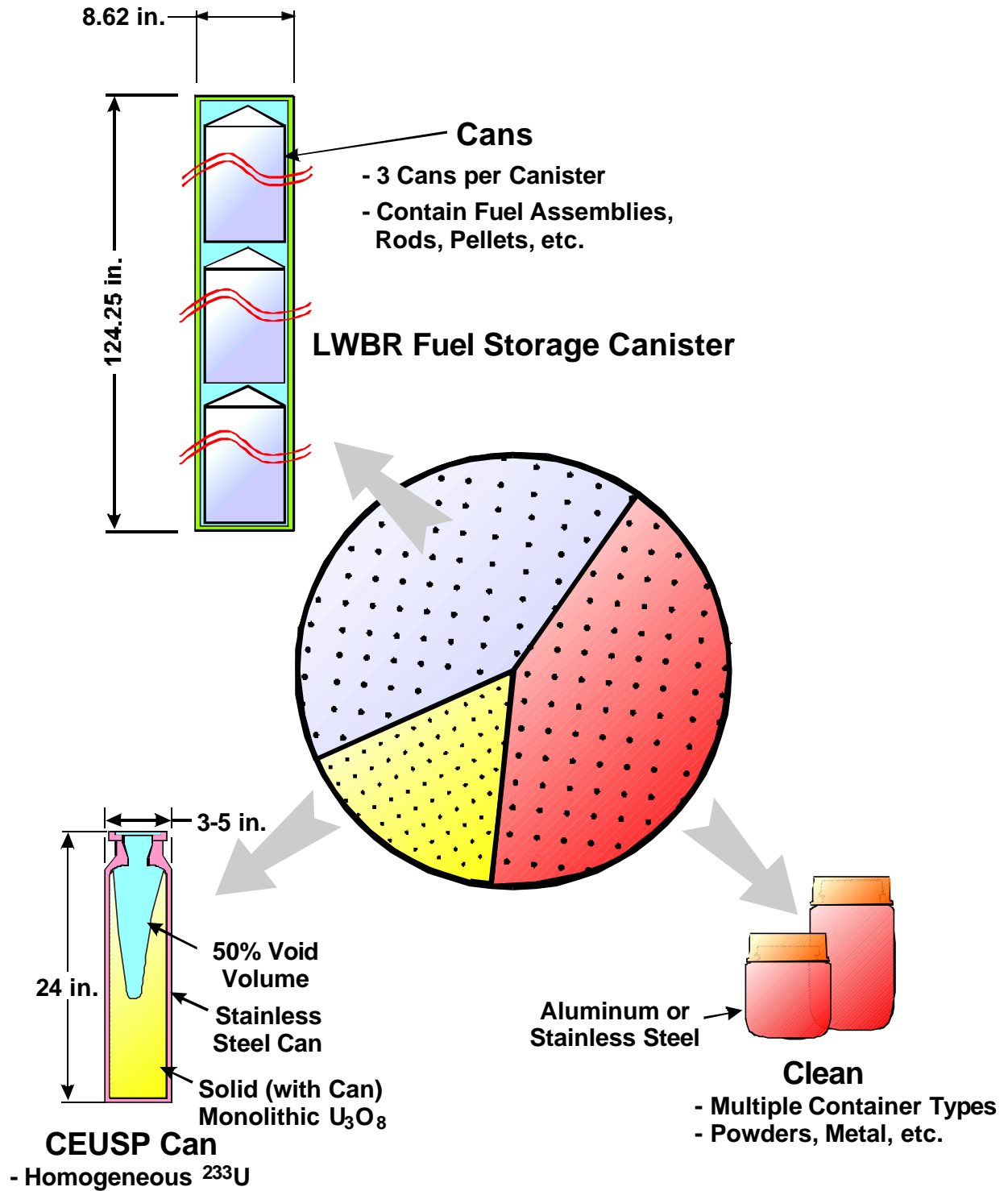

Fig. 2.4. Uranium-233 inventory is currently stored in different containers.

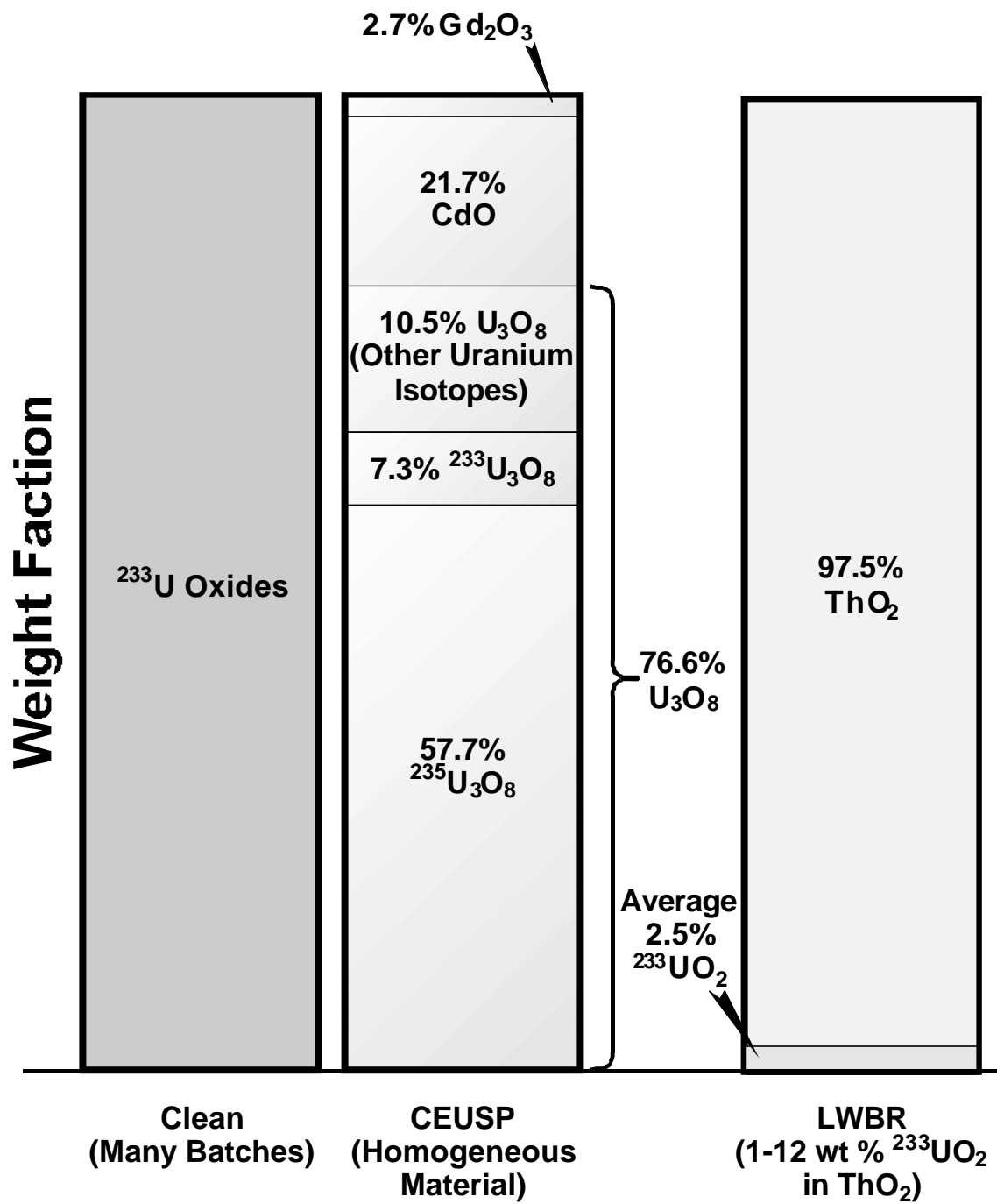

Fig.2.5. Chemical composition of the ^{233}U inventory.

Table 2.3. Inventory of ²³³U SNF (not part of disposition program)

Batch no.	Storage site (reactor)	Total U (kg)	Uranium isotopics	
			²³³ U (kg)	²³² U (ppm)
1	Savannah River Site (SRS) (Dresden)		15.4	high
2	SRS (Elk River)		14.7	high
3	SRS (Sodium Reactor Experiment)		1.1	high
4	INEEL (Ft. St. Vrain)	308.3	90.1	48.3
5	Colorado (Ft. St. Vrain)	822.5	236.0	53.4
6	INEEL (Peach Bottom I)	206.6	20.5	7.1
7	INEEL (Peach Bottom II)	127.8	25.9	58.6
8	INEEL (LWBR)		523.7	220.
Total			927.4	

Second, the CEUSP ^{233}U has a high concentration of ^{232}U . This results in a significant gamma radiation field near the containers.

Third, the packaging system for the CEUSP uranium is unusual—the ^{233}U oxide is a monolithic block and is physically bound to its stainless-steel container. The oxide can be removed from the package only by chemical dissolution or an equivalent mechanical means. If the container is cut open, the uranium oxide can not be removed physically from the package using conventional techniques (i.e., powder pouring) and must be chemically or mechanically extracted. A special loading procedure was used for the CEUSP uranium. Each stainless steel package was placed vertically in a high-temperature furnace, and the ^{233}U was added as a concentrated uranyl nitrate solution. In the package, the nitrate decomposed to an oxide. This created a cast-in-place monolithic ceramic in each storage package.

Last, the CEUSP material also contains cadmium and gadolinium, which were added as neutron absorbers to prevent nuclear criticality of the material while it was in liquid storage—before it was solidified into its current form. Under some circumstances, the presence of a Resource Conservation and Recovery Act (RCRA) metal impacts how the material must be handled or disposed of.

2.2.1.3 LWBR ^{233}U

The LWBR program investigated the use of ^{233}U –Th nuclear fuels. When the program was shut down, unirradiated fresh fuel assemblies, fuel rods, fuel pellets, and other assorted materials were placed in storage at INEEL. While the material is in several package types, it consists of 1 to 12 wt % $^{233}\text{UO}_2$ in high-fired (1,750 °C for 12 hours) ThO_2 . The average assay is ~2.5 wt % $^{233}\text{UO}_2$ in ThO_2 . For the ^{233}U – ThO_2 pellets in fuel rods, the assay varies depending upon the location within the fuel rods. There are also many pure ThO_2 pellets in some of the fuel rods. The ^{233}U in this batch of material is of a high quality with a variable, but low, ^{232}U content. Most of the material contains <10 ppm ^{232}U .

The characteristics of this material have two implications in terms of disposition. First, for any option, there would be a front-end, mechanical sorting process to separate ^{233}U – ThO_2 pellets from packaging materials, clad, ThO_2 pellets, and other materials. Second, the chemical form of this feed requires that if this material is to be disposed of, then either: (1) the disposition option must be able to tolerate large quantities of ThO_2 or (2) separation of the ^{233}U from the thorium is required before the disposition of the ^{233}U .

2.2.2 Quality

The three primary inventory categories can be further divided into eight major batches based on the characteristics of the ^{233}U (Table 2.2). The remainder of the inventory is a 9th batch (of miscellaneous small quantities). The quality of the batches can be measured by two indices. Most batches are almost isotopically pure ^{233}U —except for Batches 1 and 8, both of which contain significant quantities of ^{235}U . For most applications (except nuclear weapons and power reactors), the high ^{235}U content minimizes the value of the ^{233}U . The second index of quality is the concentration of ^{232}U in the ^{233}U . If the ^{232}U concentration is high, the near-term radiation levels associated with these batches will be high.

3. GOALS AND CONSTRAINTS

This report describes storage and disposal options for ^{233}U . However, a set of factors (definition of weapons-usable ^{233}U , nuclear criticality, waste management, etc.) strongly influence both the choice of preferred options and how any specific option would be implemented. These factors are discussed herein.

3.1 GOALS

The primary goal of the disposition program is to make surplus weapons-usable fissile material unsuitable for weapons use. Weapons-usable ^{233}U can be converted to non-weapons-usable ^{233}U by isotopically diluting it with DU. Isotopic dilution can be used to down-blend ^{233}U for storage and future use when the application does not require weapons-usable ^{233}U (Sect. 3). Isotopic dilution is used in most proposed ^{233}U disposal options. Isotopic dilution is the same strategy (DOE June 1996a; DOE July 29, 1996) as that chosen to convert HEU to non-weapons-usable LEU.

National and international safeguards requirements (DOE Orders, NRC regulations, IAEA agreements) for weapons-usable materials have been developed for HEU and WGP; however, the requirements are not developed fully for the disposition of surplus ^{233}U . For uranium containing ^{235}U , these regulatory requirements recognize that only HEU can be practically made into nuclear weapons. It is agreed to by DOE orders, NRC regulations, and IAEA conventions that isotopically diluting HEU to <20 wt % ^{235}U with DU converts the HEU to non-weapons-usable material.

For ^{233}U , the regulations (IAEA August 1993) do not recognize that mixing ^{233}U with DU will create a mixture that is unsuitable for manufacturing nuclear weapons. It is recognized within the technical community that isotopic dilution with DU will eliminate the ^{233}U as a weapons-usable material. Historically, there never was any consideration to convert ^{233}U to a non-weapons-usable material; thus, the required regulatory structure was not established. The technical basis for defining non-weapons-usable ^{233}U by diluting ^{233}U with ^{238}U has been recently developed (Forsberg et al. March 1998). Actions are being undertaken to arrive at national and international consensus on the level of isotopic dilution required to make ^{233}U non-weapons-usable. The studies indicate that uranium with a ^{233}U content of <12 wt % in ^{238}U is non-weapons-usable uranium. This concentration is equivalent to uranium with a ^{235}U content <20 wt % in ^{238}U .

For mixtures of ^{233}U , ^{235}U , and ^{238}U , effectively non-weapons-usable uranium is defined by the following formula:

$$\frac{\text{Weight of } ^{233}\text{U} + 0.6 \text{ weight of } ^{235}\text{U}}{\text{Weight of total uranium}} < 0.12 \quad (1)$$

For the studies herein, the previous formula was used to determine the quantities of DU needed to make ^{233}U a non-weapons-usable material. One kilogram of ^{233}U requires 7.407 kg of DU containing 0.2 wt % ^{235}U to convert ^{233}U to non-weapons-usable uranium.

3.2 STORAGE OPTIONS AND CONSTRAINTS

3.2.1 Storage Policy Options

Some or all of the ^{233}U may be placed into long-term storage. Storage is unlike other disposition options. All disposal options are identical at a fundamental policy level—material is disposed of. However, different storage options imply different policies. There are three long-term storage options in terms of the isotopic concentration of ^{233}U in the stored material (Fig. 3.1). The three isotopic concentrations imply different policies.

3.2.1.1 Store As-Is

The ^{233}U material can be placed in long-term storage containers in its current isotopic form—weapons-usable ^{233}U . As a policy, this is (a) the no-action option or (2) a decision that ^{233}U should be kept for all possible future uses. It is not disposition. Future use may include commercial and defense applications. The quality of the ^{233}U slowly improves with time as the ^{232}U impurity decays at a half-life of 72 years.

In response to the recommendations of the U.S. Defense Nuclear Facilities Safety Board (DNFSB) Recommendation 97-1 (DNFSB March 3, 1997), DOE (Pena September 25, 1997) has initiated a program to ensure safe, long-term storage of ^{233}U and development of a long-term storage standard. Because ^{233}U is weapons-usable material, it must be stored in a high-security vault.

3.2.1.2 Isotopically Dilute to Non-Weapons-Usable ^{233}U for Future Use

The ^{233}U can be isotopically blended with DU and thus converted to non-weapons-usable ^{233}U . This implies isotopic dilution by a factor of ~ 7 with DU to < 12 wt % ^{233}U in ^{238}U . The ^{233}U would remain useful for many, but not all, nonweapons applications. In particular, the ^{233}U could be used for production of medical isotopes (Hall July 22, 1998; Feinendegen and McClure May 1996). Conversion to non-weapons-usable ^{233}U allows the ^{233}U to be stored using industrial security levels rather than those required for weapons-usable material. This implies significant savings in storage costs. The same storage standards being developed for high-assay material (Sect. 3.2.1.1) would be expected to apply to this material.

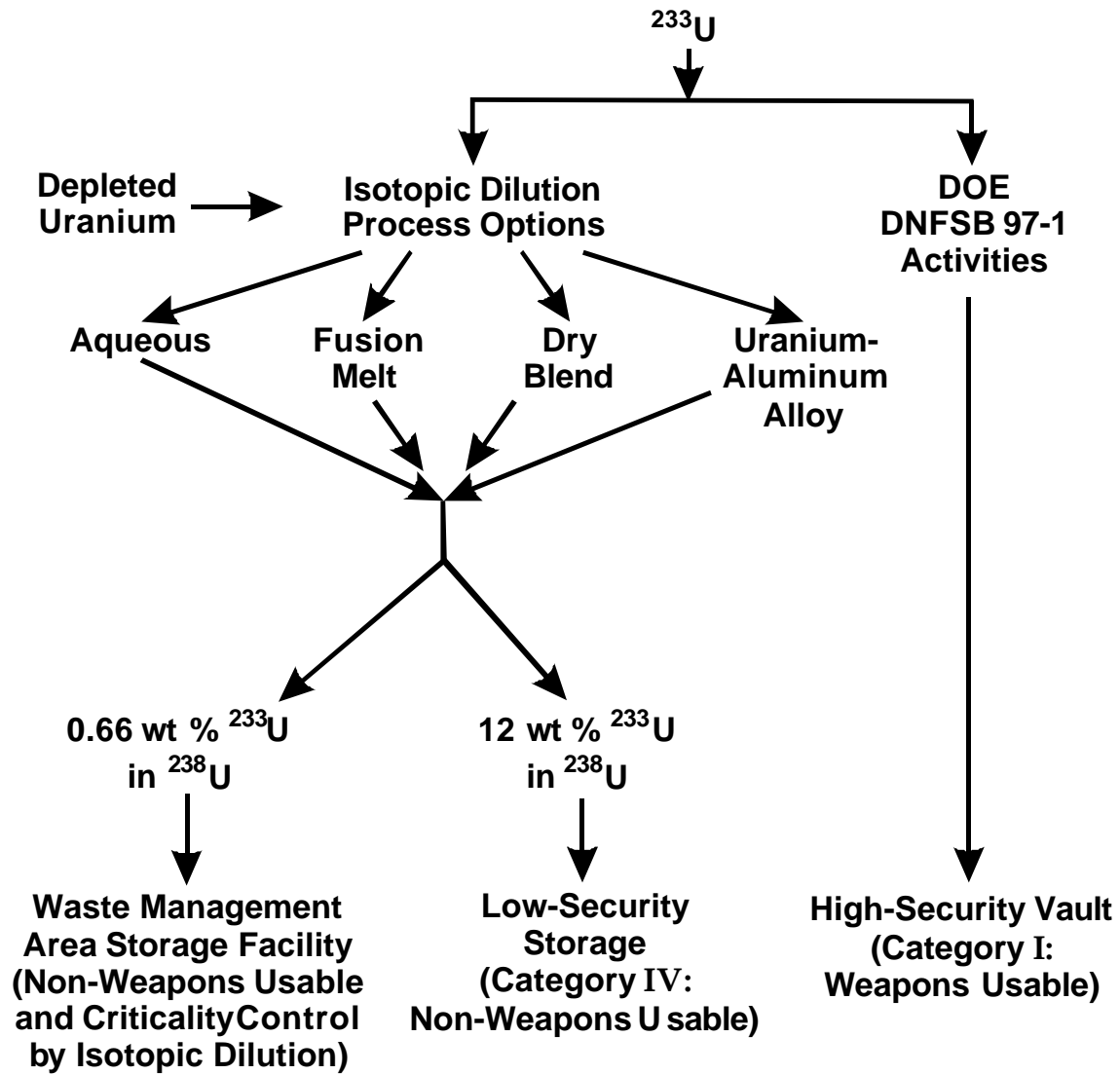

Fig.3.1.Uranium-233 storage options.

3.2.1.3 Isotopically Dilute to Critically Safe ^{233}U

The ^{233}U can be isotopically diluted to convert it to non-weapons-usable ^{233}U and to eliminate the potential for long-term nuclear criticality. The material would then become a waste that is awaiting disposal. The required isotopic dilution is <0.66 wt % ^{233}U in ^{238}U to eliminate the potential of nuclear criticality and essentially renders the mixture unusable for all potential applications. It becomes unusable because of (1) isotopic impurities or (2) the prohibitive cost of processing the bulk of the material to access some desirable decay product.

This is a distinct and separate option from use options (keep as weapons-usable material or convert to non-weapons-usable ^{233}U) or the disposal options. The disposal options lead to defined end points. This option leads to long-term storage with disposal to be addressed at a later date. It is potentially viable because DOE has a significant inventory of existing ^{233}U wastes (Forsberg, Storch, and Lewis July 7, 1998) with no defined disposal site. Consequently, adding a few hundred additional drums of waste of isotopically diluted ^{233}U to this existing inventory of several thousand drums would not significantly increase the waste management activities or costs. No new management system for a new waste form would be needed. The option (1) does allow the conversion of weapons-usable ^{233}U into a non-weapons-usable ^{233}U -containing waste; (2) reduces storage costs because of a lessened need for security requirements; and (3) does not create new waste management problems. Storage as an end point is further described in Sect. 3.3.5.

3.2.2 Impact of Potential Uses of ^{233}U on Storage and Disposal Options

There are several potential uses for ^{233}U and its decay products. Figure 3.2 summarizes the larger potential uses. For many applications, the ^{233}U may be downblended with ^{238}U to nonweapons-usable material and still be useful. Consequently, many of the disposition options to downblend ^{233}U described in this report are potentially useful even if the ^{233}U is kept for future use. Table 3.1 defines uses for ^{233}U and whether the specific use requires weapons-usable ^{233}U or nonweapons-usable ^{233}U .

The major potential uses of ^{233}U and the potential implications on ^{233}U storage and disposal are summarized below.

3.2.2.1 Medical Applications

One potential large-scale use for ^{233}U involves one of its decay products, ^{213}Bi for cancer treatment. Specifically of interest is that of antitumor antibodies radiolabeled with an alpha emitter (Knapp and Mirzadeh 1994; Geerlings 1993). In this method, the radioisotopes are attached to antibodies that specifically target cancer cells; the resulting alpha emissions kill these cells with high efficiency. Initial clinical trials using ^{213}Bi on human patients at the Sloan-Kettering hospital in New York City have been favorable.

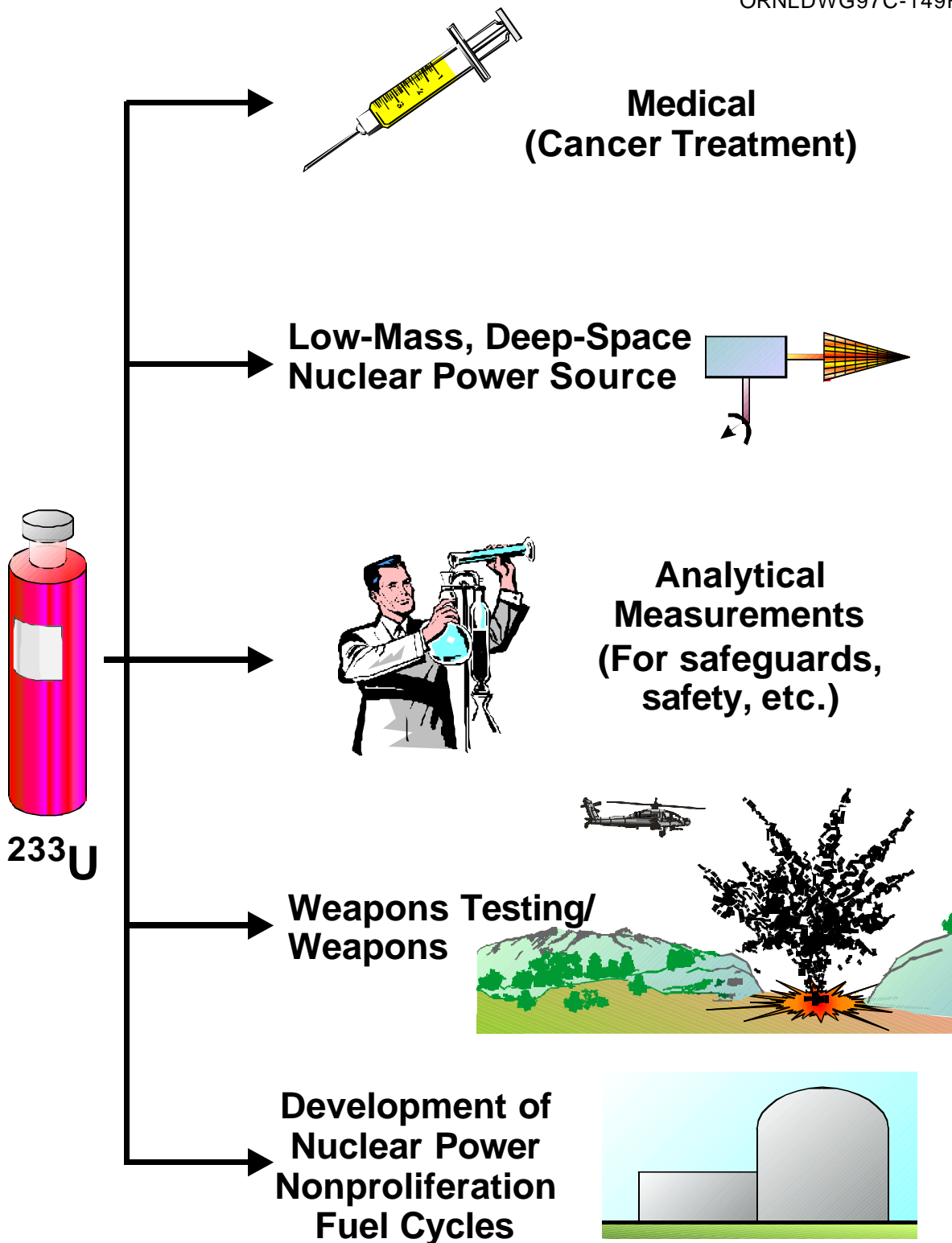

Fig. 3.2. Potential uses for ^{233}U .

Table 3.1. Uranium-233 uses, applicable ²³³U categories, and isotopic requirements

Use	Applicable ²³³ U category			Acceptable isotopic composition in ²³⁸ U		
	Clean	CEUSP	LWBR	Weapons (>>12 wt %)	Nonweapons (<12 wt %)	Critically safe (<0.66 wt %)
Medical (cancer treatment)	Yes	Yes	No	^a	^a	^a
Low-mass reactor (deep-space reactor)	Yes	No	Yes	Yes	No	No
Analytical (safeguards, etc.)	Yes	No	Yes	Yes	Yes	No
Weapons (test, use)	Yes	No	Yes	Yes	No	No
Nonproliferation fuel cycle [research and development (R&D)]	Yes	No	Yes	^a	^a	No

^aFor these applications, it is unclear what ²³³U concentrations in ²³⁸U would be acceptable or preferred.

Recovery of ²¹³Bi for this application involves a three-step process (Fig. 3.3). First, ²³³U is dissolved in acid and ²²⁹Th and its decay products are separated from the uranium by ion exchange. The resulting thorium-bearing solution contains essentially no fissile uranium, has no nuclear weapons use, and, therefore, poses no complications in terms of safeguards or nuclear criticality. Next, ²²⁵Ac is separated from ²²⁹Th and the other decay products. Because actinium is not a part of the decay chain of ²³²U, this separation removes the undesirable product ²⁰⁸Tl and its precursors. Finally, a biomedical generator system may be loaded with ²²⁵Ac, from which ²¹³Bi may be “milked”.

After the first recovery step, the remaining uranium in solution is resolidified. There are several options for this ²³³U.

- The ²³³U can be saved as a future source of ²²⁹Th or for other purposes. After several years to allow for ingrowth of ²²⁹Th and other decay products, the process can be repeated to recover more ²²⁹Th. If the ²³³U is to be placed in storage, there is the option of isotopically diluting it with ²³⁸U to nonweapons-usable ²³³U before the ²³³U is resolidified. This would increase the mass of uranium that must be processed in the future to recover ²²⁹Th; but it would reduce security requirements. It is not currently known which option is more economic.

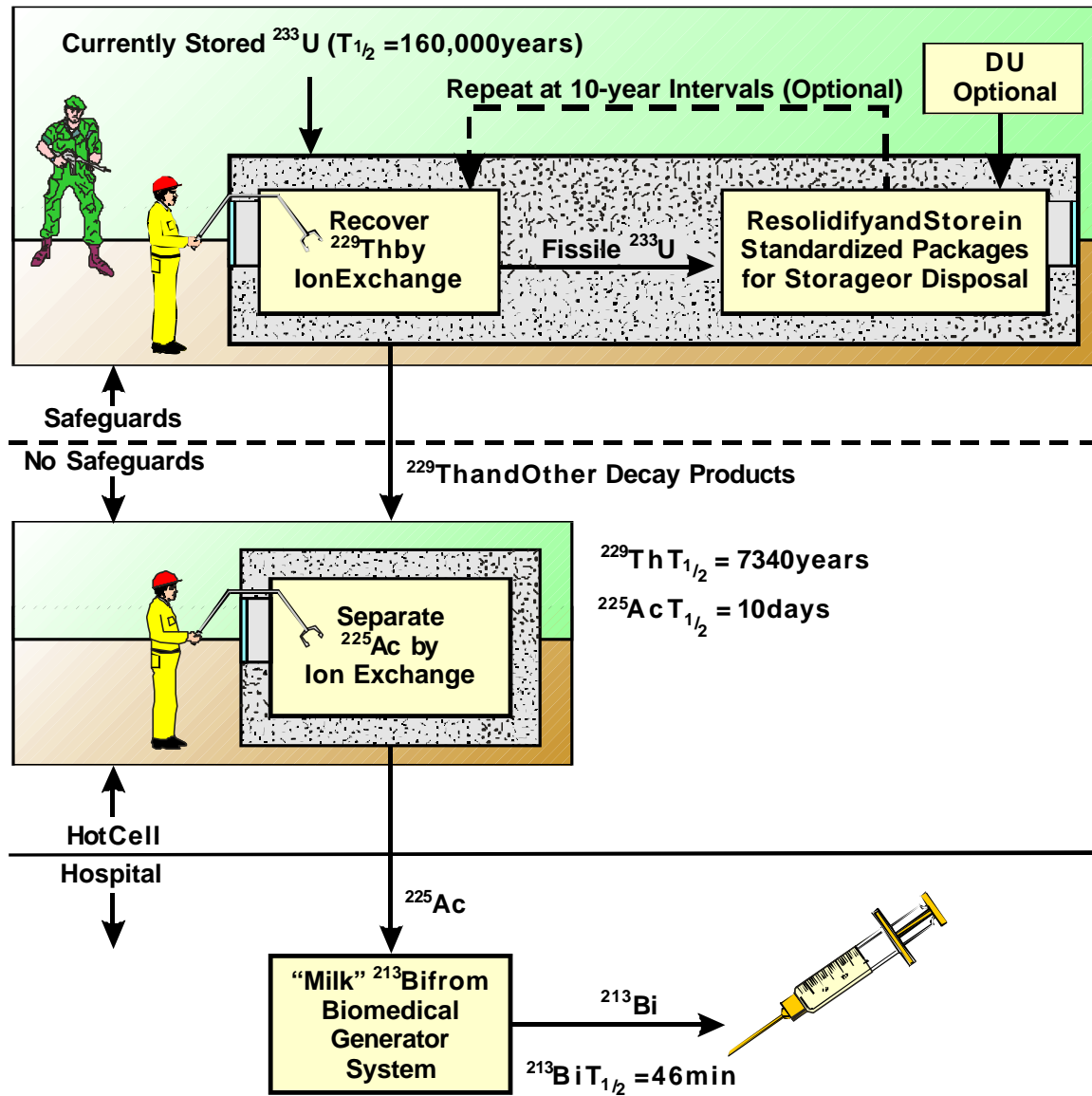

Fig.3.3. Flowsheet for ^{213}Bi production for treatment of cancer.

- The ^{233}U may be disposed of as a waste. Because of the long half-life of ^{229}Th ($T_{1/2} = 7,340$ years), separated ^{229}Th can be used to produce useful ^{225}Ac and ^{213}Bi for decades. Depending upon processing losses of ^{229}Th and growth in ^{213}Bi demand, there may or may not be a need for additional ^{229}Th from ^{233}U after the initial ^{229}Th recovery.

The clean and CEUSP ^{233}U can be used in the near-term for medical applications. The LWBR ^{233}U contains ~14 tons of ThO_2 . It is not practical to isotopically separate the ^{229}Th from the natural ^{232}Th in the LWBR material. If it was desired to obtain ^{229}Th from the LWBR ^{233}U , the following steps would be required: (1) separate ^{233}U from the thorium, (2) store ^{233}U for many years to allow buildup of ^{229}Th , and (3) recover newly created ^{229}Th from the ^{233}U . The current inventory of ^{229}Th is shown in Fig. 3.4. The largest amount is in the CEUSP ^{233}U . This reflects the fact that this material has been in storage for a long time. This long-term storage has allowed the buildup of the ^{229}Th decay product.

3.2.2.2 Low-Mass Reactors for Deep-Space and Other Special-Purpose Missions

Because ^{233}U has a lower minimum critical mass than ^{235}U or ^{239}Pu (for neutron flux in the thermal regime), it may be desirable to use it as a nuclear reactor fuel for deep-space missions, for which a premium is placed on minimizing mass. For this application, weapons-usable ^{233}U would be used to minimize the launch weight of spacecraft. A space reactor is first put into earth orbit and then is started. This procedure avoids the need for massive shielding of the reactor before and during launch operations.

The preferred type of nuclear power source to provide electricity for a deep-space mission depends upon the energy and power requirements.

- For power production levels up to many kilowatts, the minimum-mass nuclear power source is a radioisotope generator. The currently preferred radioisotope is ^{238}Pu . Nuclear reactors provide minimum-mass, steady-state power generation at higher power levels. For steady-state power levels of a few kilowatts to several megawatts, nuclear power reactors fueled with ^{233}U may provide the minimum mass (MacFarlane 1963; Lantz and Mayo 1972). For each fissile material, a minimum mass of that fissile material is required for a nuclear reactor to operate. This minimum mass is substantially smaller for ^{233}U than for ^{235}U . Uranium-233 and plutonium have similar nuclear characteristics; however, the physical properties of uranium in high-temperature space reactors are substantially better than those of plutonium, and there may be fewer launch safety issues. These features may make ^{233}U the preferred material for such applications.

At higher-power levels, the reactor must have large internal heat-transfer surfaces to transfer heat from the reactor to the electric generator. The reactor fuel assemblies to obtain the heat transfer require a significant amount of fissile material. In a large nuclear system, the choice of fissile material does not significantly impact weight because the amount of fissile material needed for heat transfer far exceeds the minimum critical mass needed for a reactor.



Top Area of Cylinder α ^{233}U Inventory

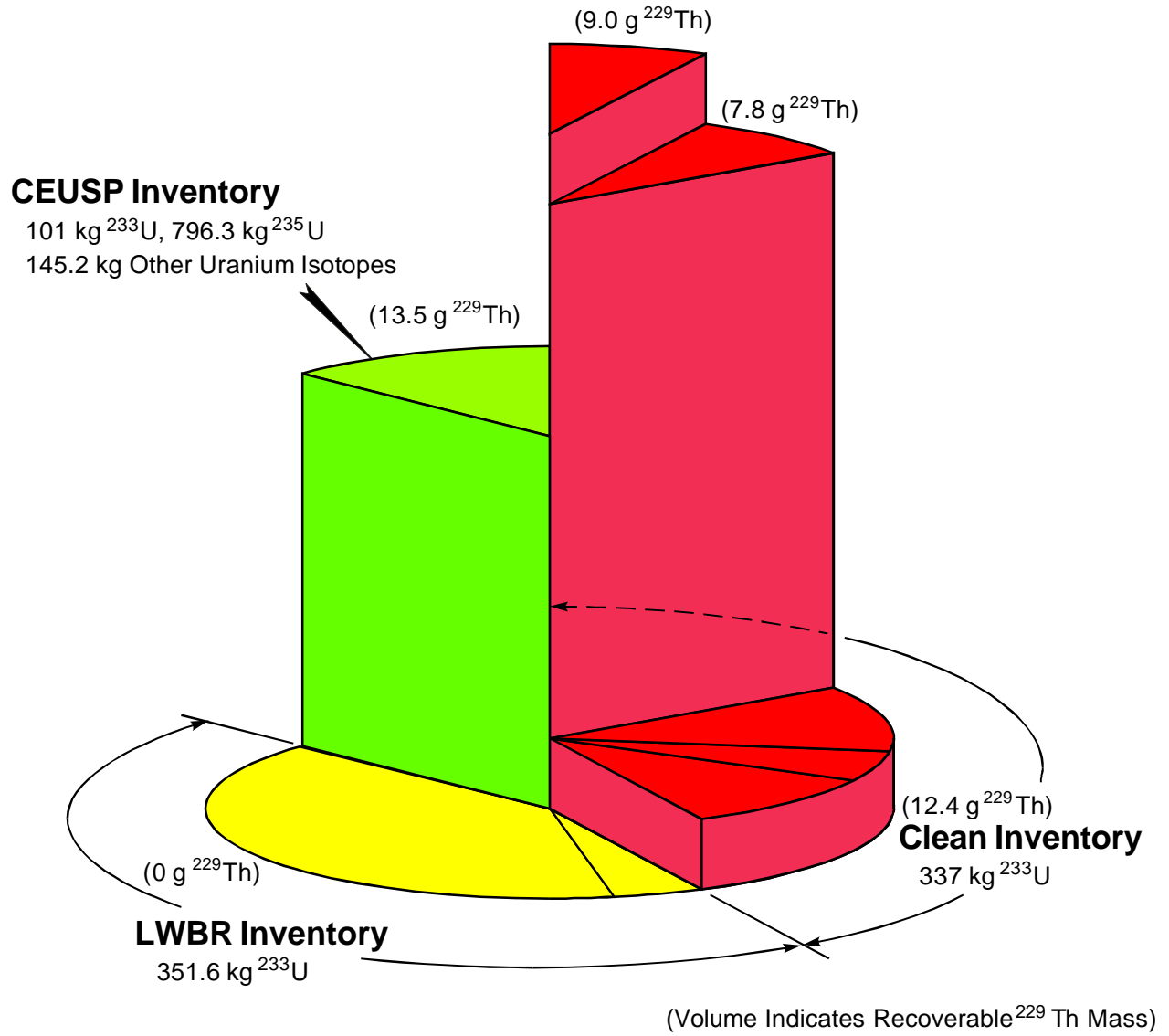

Fig. 3.4. Recoverable ^{229}Th from the U.S. ^{233}U inventory.

- The total mission energy requirements also impact the choice of fuel for a space reactor. In missions with large total energy requirements, there must be significant quantities of fissile materials in the reactor to provide the energy for a long-term mission. Reactor mass is not determined by the choice of fissile material. HEU becomes the preferred material.

Uranium-233 may also be used for small nuclear propulsion units to boost spacecraft from earth orbit to deep space (Ludewig et al. 1989; Hyland 1970). These units have moderate-power levels for short times (<1 h). The interest in using ^{233}U is that it minimizes weight.

For all these applications, only weapons-usable ^{233}U would be used. This includes the clean and LWBR ^{233}U . The CEUSP material would not be used since it is isotopically diluted with HEU.

3.2.2.3 Analytical Tracer

The ^{233}U isotope is used as a calibration spike in the determination of uranium concentrations and isotopic compositions in materials containing natural uranium or uranium enriched in ^{235}U . This type of analytical procedure is used as part of many safeguards and production operations. There are also other analytical applications. While the quantities of material used are very small (typically fractions of a gram), pure ^{233}U is desired for such applications.

3.2.2.4 Nuclear Weapons Research

Because ^{233}U is fissile, it has the potential to be used in nuclear weapons. Some ^{233}U may be kept for research. By definition, only weapons-usable ^{233}U is used for this application.

3.2.2.5 Reactor Fuel Cycle Research

The major historical application for ^{233}U has been for research into new nuclear power reactors and associated fuel cycles. This is also a potential future application. There are four incentives for considering a ^{233}U -thorium fuel cycle.

- The global resources of thorium are about four times greater than those of uranium. If uranium becomes scarce, thorium is a more abundant fertile material to use in reactors to breed nuclear fuels.
- In thermal reactors, such as light-water reactors (LWRs), thorium fuel cycles breed more fissile material (^{233}U) than reactors fueled with LEU.
- SNF and other wastes from the thorium- ^{233}U fuel cycle, when compared to uranium-plutonium fuel cycles, contain far smaller quantities of long-lived actinides that are a concern in wastes to be disposed in geological repositories.
- Some ^{233}U -thorium fuel cycles have significantly lower risks of diversion of weapons-usable material than conventional uranium-plutonium fuel cycles. In power reactors, the impurity ^{232}U and its daughter products build up to very high levels with correspondingly high radiation levels associated with the separated ^{233}U .

Clean and LWBR ^{233}U would be used for this application. Because of the unusual isotopics of the CEUSP ^{233}U , it would not be used for this potential application.

3.3 DISPOSAL OPTIONS AND CONSTRAINTS

There are several constraints that strongly impact multiple disposition options. These are described herein.

3.3.1 Criticality Control

Nuclear criticality must be avoided in any process or disposal facility. Nuclear criticality can be prevented by controlling equipment and facility geometry, limiting the quantity of fissile material in the system, adding neutron absorbers, or isotopically diluting ^{233}U with DU. Nuclear criticality avoidance by isotopic dilution is the addition of ^{238}U sufficient such as to lower the ^{233}U purity level below that at which nuclear criticality can occur. Isotopic dilution with DU is a preferred criticality control option for many ^{233}U disposition options based on the following considerations:

- *Process criticality control.* For relatively small quantities of ^{233}U , strong economic incentives exist to use already existing waste management and processing facilities. Existing waste management facilities are not designed for fissile materials or criticality control. The process equipment geometry in most cases is not critically safe. Avoiding criticality by limiting the quantity of fissile material in a process system is usually not economical because the minimum critical mass of pure ^{233}U is only 520 g for an optimized aqueous system. This implies that the system at any given time must contain <520 g of ^{233}U . The addition of neutron absorbers can prevent nuclear criticality, but this action requires full control of the chemistry to avoid the potential for separating the ^{233}U from the neutron absorber during the process. Because of these considerations, isotopic dilution is the preferred method for criticality control in many process options.
- *Repository criticality control.* It is difficult to rely on the geometry or chemical composition alone within disposal facilities to control criticality over geological time frames. Several mechanisms can cause changes in waste geometry and chemistry, including groundwater transport of uranium and mechanical disturbances of the waste. If criticality control is to be ensured for thousands of years by either geometric or chemical control (including neutron absorbers), system performance must be predictable for these lengths of time. Such predictions are difficult to make, and they are subject to substantial uncertainties. No such difficulties exist when isotopic dilution is used for criticality control. In this context, the U.S. Nuclear Waste Technical Review Board (NWTRB), the Congressionally mandated review board for the proposed Yucca Mountain (YM) geological repository, has also recommended considering the use of DU to isotopically dilute fissile uranium materials to prevent the potential for nuclear criticality in geological repositories containing fissile material (NWTRB 1996). Finally, a recent NRC report made similar recommendations on the use of DU for criticality control in various disposal facilities (NRC June 1997).

- *Legal precedent.* The environmental impact statement (EIS) (DOE June 1996a) and record of decision (DOE July 29, 1996) for the disposition of excess HEU recommended isotopic dilution of the fissile ^{235}U if any HEU was disposed of as a waste. This dilution eliminates the potential for nuclear criticality in disposal sites. The previous considerations, as they were applied to ^{235}U , were the basis for this decision. This precedent suggests that a similar criticality strategy may be used for any ^{233}U that becomes waste.

To ensure control of nuclear criticality for ^{233}U by isotopically diluting ^{233}U with ^{238}U , the ^{233}U concentration must be reduced to <0.66 wt % (Elam November 1997). In terms of nuclear criticality safety, this concentration is equivalent to ^{235}U at an enrichment level of ~ 1.0 wt %—a level which will not result in nuclear criticality under conditions found in processing or disposal facilities. These uranium isotopic concentrations avoid the need to control other parameters to prevent nuclear criticality; that is, the ^{233}U can be treated as just another radioactive waste. At these concentrations, nuclear criticality will not occur either in a geological environment, over time, nor in waste processing operations that have not been designed for fissile materials.

For mixtures of ^{233}U and ^{235}U , the amount of DU (with 0.2 wt % ^{235}U) in grams (g) required to ensure criticality control by isotopic dilution in a water-moderated system is the following:

$$\text{g DU} = 188 \times \text{g } ^{233}\text{U} + \left(\frac{\text{E} - 1}{0.8} \right) \times \text{g of enriched uranium} \quad , \quad (2)$$

where

$$\begin{aligned} \text{DU} &= \text{grams of DU (0.2 wt \% } ^{235}\text{U) and} \\ \text{E} &= \text{the weight percent of } ^{235}\text{U, where the grams of enriched uranium} = \text{total U} - ^{233}\text{U.} \end{aligned}$$

In the previous equation, ^{234}U and ^{236}U may be considered to be ^{238}U —providing the atom ratio of the ($^{234}\text{U} + ^{236}\text{U}$): ^{235}U does not exceed 1.0. If the quantity of grams of DU calculated is negative, the uranium material already contains sufficient ^{238}U such as to ensure subcriticality; therefore, no additional DU is needed. For 1 kg of ^{233}U , 188 kg of DU with 0.2 wt % ^{235}U is necessary to minimize criticality concerns. This results in a ^{233}U enrichment of 0.53 wt %.

3.3.2 Waste Definitions and Legal Constraints

For historical reasons, ^{233}U disposal was not included in the enabling legislation for many disposal sites. Consequently, there are a set of legal issues and constraints in terms of disposal of ^{233}U as a waste material after it has been converted into a non-weapons-usable form. These can be classified into three categories.

- *Co-processed wastes.* If the ^{233}U is mixed with another more hazardous waste, the technical and legal requirements for that waste will usually control the final disposition. For example, if the ^{233}U is mixed with DU, converted into reactor fuel, irradiated in a nuclear reactor, and discharged from the reactor as SNF, the legal definition and requirements for disposal of the SNF would apply. The fact that the fuel contains ^{233}U is not important in this context. DOE currently owns SNF containing ^{233}U , which is being treated for disposal as SNF—not as a ^{233}U waste form. There are several other similar options such as blending ^{233}U with high-level waste (HLW) (Sect. 4.1) or blending ^{233}U with TRUW (Sect. 4.6).

Coprocessing of ^{233}U with a waste does not necessarily require mixing of the ^{233}U with the waste on an atomic scale. For example, it is proposed to dispose of excess plutonium by (1) converting the plutonium to a high-grade ceramic, (2) placing the ceramic in cans, (3) placing the small cans in empty HLW canisters, and (4) pouring HLW glass around the cans while filling the HLW canister. In this example, the plutonium ceramic is mechanically distinct and separate from the HLW glass. The NRC (Paperiello January 25, 1999) has recently stated that “the staff is not aware of any existing legal or regulatory provisions that would prevent disposal of immobilized plutonium waste forms in a high-level waste repository.” This precedent indicates codisposal of ^{233}U with various HLW or SNF forms is potentially viable. It has not been defined how tightly coupled the fissile waste form must be to the HLW or SNF to be legally treated as HLW or SNF and meet the legal requirements for waste to be accepted by such facilities.

- *Direct disposal in a WIPP-type facility.* Several disposition options for ^{233}U include isotopic dilution of ^{233}U with DU followed by disposal of the material as a waste to a WIPP-type disposal facility. WIPP is designed for wastes for which the primary hazard is alpha radiation. The primary hazard of ^{233}U is alpha radiation; thus, WIPP is technically suitable for accepting ^{233}U wastes. Historically, ^{233}U wastes have been treated as TRUWs. However, the enabling legislation for WIPP (U.S. Congress October 30, 1992) defined WIPP for disposal of TRUW—elements with atomic numbers above 92 (uranium). This does not include ^{233}U . If ^{233}U is to be ultimately disposed of as a ^{233}U waste in WIPP, changes in the enabling legislation will be required if the material is sent to WIPP.

There are related WIPP-type disposition options with different types of constraints. By law (U.S. Congress 1996), WIPP is authorized to receive and dispose of 175,600 m³ of TRUW generated from defense operations. DOE, in the EIS for WIPP (September 1997), has determined that another 142,000 m³ of wastes may require disposal by the year 2033 in a geologic disposal facility such as WIPP. Much of this waste does not yet exist in packaged form; it will be generated as old cold-war facilities are decontaminated and decommissioned. These wastes include added defense TRUW, other government TRUW generated from nondefense activities, and other wastes that may require geological disposal. The other wastes include *existing* wastes containing ^{233}U that are in storage—primarily at ORNL and INEEL (Forsberg, Storch, and Lewis July 7, 1998). Because of the 142,000 m³ of other wastes that ultimately will require disposal, either (1) a second WIPP-type facility must be built, (2) WIPP must be expanded with congressional authorization to accept these other materials, or (3) some new option must be identified. As a consequence, there are effectively two WIPP-type disposal facility options with different constraints: (1) use the existing WIPP after changes in the enabling legislation allow the disposal of ^{233}U wastes from disposition activities or (2) store any future ^{233}U disposition waste designed for WIPP-type disposal with existing ^{233}U -containing wastes awaiting a disposal facility.

- *Direct Disposal in HLW-SNF repository.* Uranium-233 may be disposed of as a stand-alone ^{233}U waste in the proposed HLW-SNF repository. The repository is technically designed to accept such waste forms. Uranium-233 mixed with DU is chemically similar to LWR SNF—uranium dioxide in metal cylinders. It is not, however, SNF. It would be classified as greater-than-class-C (GTCC) low-level waste (LLW) not suitable for shallow land burial if regulated under the rules of the NRC or special case wastes if regulated under DOE orders or could it be classified as HLW by petition to the NRC. In any case, because of the unique characteristics of the material, unique regulatory issues would need to be addressed.

3.3.3 Interactions Between and Among Disposal Site Criticality Control, Waste Volumes, and Costs

For many disposal options, there are two variants: (1) isotopically dilute the ^{233}U to 12 wt % in ^{238}U to convert it to non-weapons-usable material or (2) further isotopically dilute the ^{233}U to 0.66 wt % ^{233}U in DU to also eliminate criticality issues in disposal sites. In most cases, the disposal options described in this report assume that the ^{233}U is isotopically diluted to 0.66 wt % ^{233}U in DU. An examination of the consequences of sending ^{233}U wastes to a WIPP-type facility (Appendix D) with different criticality control strategies is provided herein to understand this constraint on options.

The WIPP waste acceptance criteria (WACs) define the requirements that must be met for a waste to be sent to a WIPP-type facility for final disposal. There are three criteria that can limit the amount of ^{233}U that can be placed in a drum:

- *Weight.* Drum weight is limited by disposal site handling equipment in WIPP-type facilities and transport vehicle weight limits.
- *Nuclear criticality.* WIPP-type criticality control strategy dependent upon mass limits of fissile materials in waste packages (WPs). This limit is 200 g ^{233}U /55-gal drum. However, if the ^{233}U is isotopically diluted with DU to eliminate criticality issues, there is no ^{233}U mass limit per drum.
- *Alpha activity limits.* The WACs limit the quantity of alpha materials per container with different limits for untreated vs treated wastes. This criteria is designed to limit the potential consequences of certain types of accidents.

Figure 3.5 and Table 3.2 summarizes these criteria for a ^{233}U waste. Uranium-233 wastes may become, depending upon the option, contact-handled (CH) or RH waste. As is evident from the table, criticality WACs control the maximum quantities of ^{233}U in a WP if fissile mass limits are used as a criticality control strategy for ^{233}U . This limit is 200 g of ^{233}U per 55-gal drum or 325 g ^{233}U per RH container. If the ^{233}U is isotopically diluted with DU, this limit disappears.

If criticality control does not control the amount of ^{233}U in a WP, other WACs would limit the amount of ^{233}U per 55-gal drum. For CH untreated waste, the alpha activity limit of 1.3 kg ^{233}U /55-gal drum is limiting. For CH treated waste, the container weight limit controls the ^{233}U content per drum. The container limit is 450 kg/55-gal drum. To control nuclear criticality by isotopic dilution, ~188 kg of DU (0.2 wt % ^{235}U) is required per kg of ^{233}U . If the drum weight limit is 450 kg and one assumes that the waste form is uranium dioxide, the drum can contain no more than 2.2 kg of ^{233}U . For RH wastes, the weight limits and alpha activity limits are by coincidence almost identical with the slightly more restrictive alpha activity limits restricting the ^{233}U per container to 16 kg ^{233}U or 5.3 kg per equivalent 55-gal drum.



Criteria	TRU Waste Category	
	Contact Handled (55-gal Drum)	Remote Handled (RH Container Accepts 3 Drums)
<p>Weight</p> 	≤ 450 kg	≤ 3600 kg
<p>Accident Consequence Control (Radioactivity)</p> 	<p>Untreated Waste ≤ 1.3 kg ^{233}U</p> <p>Treated Waste ≤ 29 kg ^{233}U</p>	≤ 16 kg ^{233}U
<p>Criticality</p> 	<p>Fissile Mass Limit ≤ 200 g ^{233}U/ Drum</p> <p>Isotopic Dilution Limit No Limit</p>	<p>≤ 325 g ^{233}U/ RH Container</p> <p>No Limit</p>

Fig. 3.5. Technical WIPP WAC constraints.

Table 3.2. Summary of WIPP WACs, as applied to ^{233}U

Constraint	Waste category	
	CH	RH
Container	55-gal drum	RH container (accepts three 55-gal drums)
Weight limit (gross)/container	450 kg	3600 kg
Criticality control strategy		
Mass limit/container	200 g ^{233}U	325 g
Isotopic limit/container	No limit	No limit
Radioactivity limit (control of handling risks)		
Untreated waste/container	1.3 kg ^{233}U	16 kg ^{233}U
Treated waste/container	29 kg ^{233}U	16 kg ^{233}U
Radiation limit/(surface)	<200 mrem/h	>200 mrem/h and <1000 rem/h

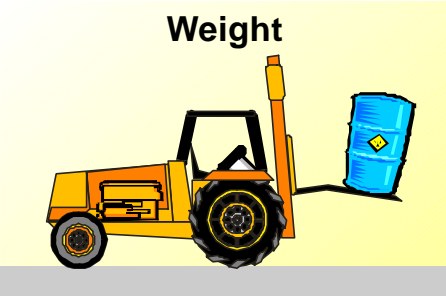
If one assumes that a metric ton (1 t) of ^{233}U is to be disposed of, about 5,000 drums are required for disposal if isotopic dilution is not used as the criticality control strategy. If isotopic dilution with DU is used for isotopic control, as few as 200 drums of waste are generated (Fig. 3.6). The average transport and disposal costs for TRUW are estimated at about \$8,000/55-gal drum (Appendix D). For WIPP-type disposal sites, using isotopic dilution as a criticality control strategy may lower disposal costs by tens of millions of dollars per ton of ^{233}U compared to using mass limits of ^{233}U per drum.

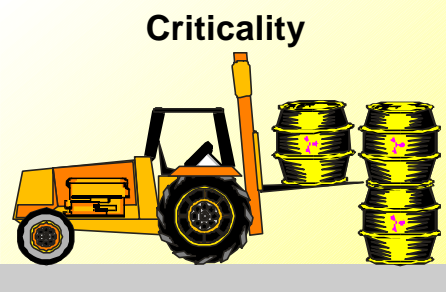
Similar interactions between and among repository WACs, criticality control strategies, safety, and costs exist or will exist for other disposal sites. For the proposed YM repository, the WACs are only partly developed. Some analysis to address these issues has been done (SNF Task Team March 1997). In most cases, disposal site WACs will strongly impact the characteristics and desirability of alternative disposition options.

3.3.4 Economics and Schedules

For historical reasons, no large production facilities were built to process ^{233}U . Because of the radiological characteristics of ^{233}U , facilities to process other fissile materials such as HEU and plutonium usually can not process ^{233}U . The total quantity of ^{233}U (<2 t) is small when compared to the total HEU (~1000 t) and to plutonium (~100 t) produced in the United States. This creates a series of practical constraints. The cost for new special-purpose facilities for ^{233}U processing will be high. These factors strongly support an examination of options that use existing facilities and existing processes. The use of existing facilities and processes implies schedules and other constraints that are imposed by the current functions of these facilities.

ORNL DWG 98C-381R

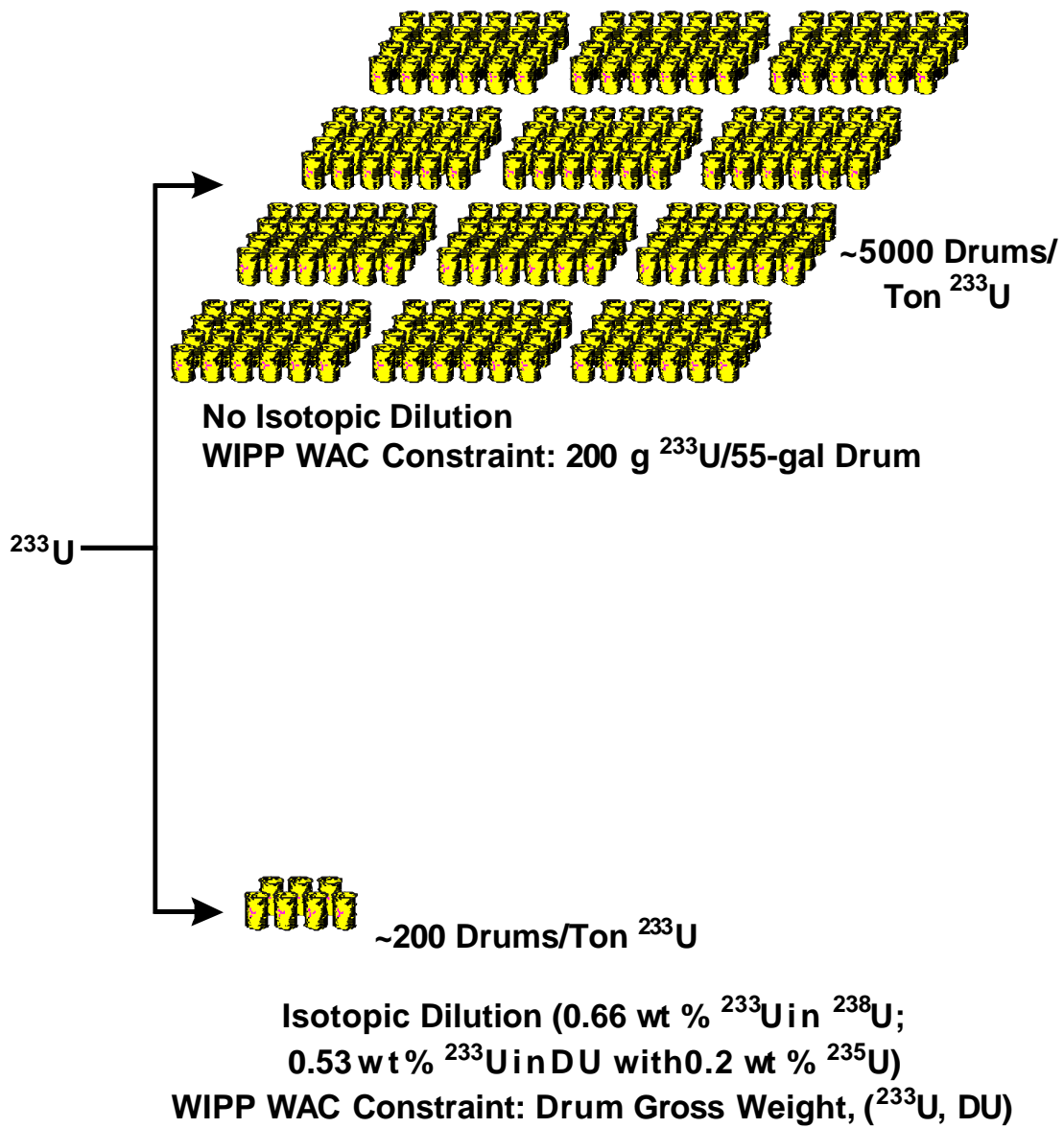

Fig. 3.6. Impact of criticality control strategy on waste volume to WIPP-type disposal site.

3.3.5 Storage for Future Disposal

As discussed in Sect. 3.2.1.3, the ^{233}U can be isotopically diluted to convert it to non-weapons-usable ^{233}U and to eliminate the potential for long-term nuclear criticality. This option can lead to long-term storage with disposal to be addressed at a later date. It is potentially viable because DOE has a significant inventory of existing ^{233}U wastes (Forsberg, Storch, and Lewis July 7, 1998). Consequently, adding a few hundred additional drums of waste of isotopically diluted ^{233}U to this existing inventory of several thousand drums would not significantly increase the existing or future waste management activities or costs. No new management system for a new waste form would be needed. The option (1) does allow the conversion of weapons-usable ^{233}U into a non-weapons-usable ^{233}U -containing waste; (2) reduces storage costs because of a lessened need for security requirements; and (3) does not create new waste management problems. However, there are several requirements for such a waste.

- *The waste form must meet WIPP WACs.* As discussed earlier, the United States does not currently have a disposal site that can accept ^{233}U wastes. The WIPP is designed for the disposal of alpha-hazardous wastes. Transuranic (TRU) and ^{233}U wastes are both alpha wastes; however, the enabling legislation does not allow the disposal of ^{233}U wastes in the WIPP (TRUW containing ^{233}U is allowed into WIPP). While the WIPP WACs strictly apply only to wastes accepted for disposal at WIPP, the WIPP WACs define the acceptable nuclear, chemical, and radiological characteristics for alpha wastes in storage, transport, or disposal. As such, the same requirements are expected to be applicable to any future waste management facility (storage or disposal) that accepts similar wastes. For this reason, existing ^{233}U wastes are managed to meet WIPP WACs. If weapons-usable ^{233}U is to be converted into a waste, it should meet the equivalent of WIPP WACs to avoid creating a new unique waste form that would require development of special storage facilities and, in the long-term, development of special disposal facilities.
- *The ^{233}U should be isotopically diluted to eliminate criticality concerns.* The WIPP facility, unlike the YM facility, is designed for radioactive wastes containing very small quantities of plutonium and other fissile materials. The WIPP criticality control strategy is based on limiting the mass of fissile material per WP to small quantities. *This criticality control strategy minimizes requirements on the chemical or radiological characteristics of the waste; but, it implies large numbers of waste containers if significant quantities of fissile materials are to be disposed of.* For ^{233}U , waste volumes can be reduced by one to two orders of magnitude by isotopic dilution of the ^{233}U with ^{238}U and using isotopic dilution rather than mass limits as a criticality control strategy. This implies large long-term cost savings (Sect. 3.3.3 and Appendix D).

4. TECHNICAL DESCRIPTIONS OF OPTIONS

Technical descriptions of each option are included herein. With each description is a one-page summary of the option.

4.1 CONVERT ^{233}U TO HLW GLASS WITH DU FROM HLW SLUDGE (DISPOSAL)

4.1.1 General Description

The ^{233}U can be mixed with existing HLW sludges (containing DU) at either the SRS or Hanford and converted with the HLW sludge to HLW glass (Table 4.1). Specific approaches may be somewhat different at the two sites. In all cases, an HLW glass product for disposal at YM is produced that meets all disposition criteria. A generic flowsheet is shown in Figure 4.1 and described later.

Many of the HLW sludges contain large quantities of DU. With appropriate selection of HLW sludges, the ^{233}U will be isotopically diluted with DU currently in the HLW sludges to meet both safeguards (<12 wt % ^{233}U) and repository nuclear criticality criteria (0.66 wt % ^{233}U when diluted with ^{238}U or 0.53 wt % ^{233}U when diluted with DU containing 0.2 wt % ^{235}U). The ^{233}U is also made unrecoverable by mixing it with HLW sludges. Of all the options, this option is expected to produce the minimum waste volumes. Minimum waste production is possible because the DU required for isotopic dilution is currently in the HLW tanks. The tanks at SRS contain about 160,000 kg of U, most of which is DU. The tanks at Hanford contain about 1.4×10^6 kg of U, most of which is DU. The DU in the HLW sludge at SRS is sufficient such as to dispose of the CEUSP ^{233}U and perhaps the entire ^{233}U inventory. Some of the tank-farm DU is committed for other criticality control purposes and additional analysis is required before it can be determined if all ^{233}U could be accepted. The DU in the HLW sludge at Hanford is sufficient such as to dispose of several times the existing inventory of ^{233}U .

The addition of ^{233}U to the HLW sludge is not expected to (1) alter processing of the HLW sludge, (2) change significantly the characteristics of the final HLW glass, or (3) impact acceptance of the HLW glass by the repository. The HLW sludge already contains large quantities of uranium. For example, the SRS HLW glass is expected to average ~2 wt % uranium because of the uranium currently in the HLW tanks. The additional ^{233}U is small in mass compared to the uranium currently in the sludge and thus is not expected to alter sludge or glass chemistry. Some ^{233}U from early site activities is already in the tanks. The HLW is highly radioactive; thus, the added radioactivity from the ^{233}U with ^{232}U impurities is not significant.

Table 4.1. Summary: Convert ^{233}U to HLW glass with DU from HLW sludge

Application	Disposal
Acceptable ^{233}U feeds	Clean, CEUSP, LWBR?
Method to convert to non-weapons-usable ^{233}U	Isotopic dilution/radiation
Disposal site	YM-type repository
Criticality control strategy	Isotopic dilution
Technical description	Excess ^{233}U is dissolved in acid, converted to an acceptable chemical form to be sent to HLW tanks, the ^{233}U feed is mixed in the tanks with HLW sludge containing DU, the mixed ^{233}U and sludge is converted to HLW glass, and the HLW glass is sent to the Yucca Mountain Repository (YMR). The process uses existing facilities at SRS or proposed facilities at Hanford. There are alternative pretreatment options such as fusion melt (Sect. 4.4) to prepare the ^{233}U for transfer to the HLW tanks.
Assessment	
Advantages	<p>Clear path to final repository disposal with a high-quality waste form.</p> <p>Allows recovery of medical isotopes before disposal.</p> <p>Capable of dissolving ^{233}U from CEUSP storage cans.</p>
Disadvantages	<p>Much of the DU in the SRS tank farm has been committed for criticality control of other fissionable materials. The available DU in the tank farm can dispose of most of the material; but, it is unclear if all ^{233}U can be disposed of. Adding DU would significantly impact ^{233}U disposal costs at this site (Hanford HLW sludge could accept the total inventory, but old facilities would have to be restarted or new facilities built to dissolve the ^{233}U).</p> <p>There are uncertainties associated with LWBR ^{233}U.</p>
Evaluation	<p>This is an attractive disposition option—particularly for the CEUSP ^{233}U. The CEUSP ^{233}U is the most radioactive ^{233}U in the inventory and contains cadmium. These characteristics are not issues if this disposition option is used. The primary uncertainty is cost.</p>

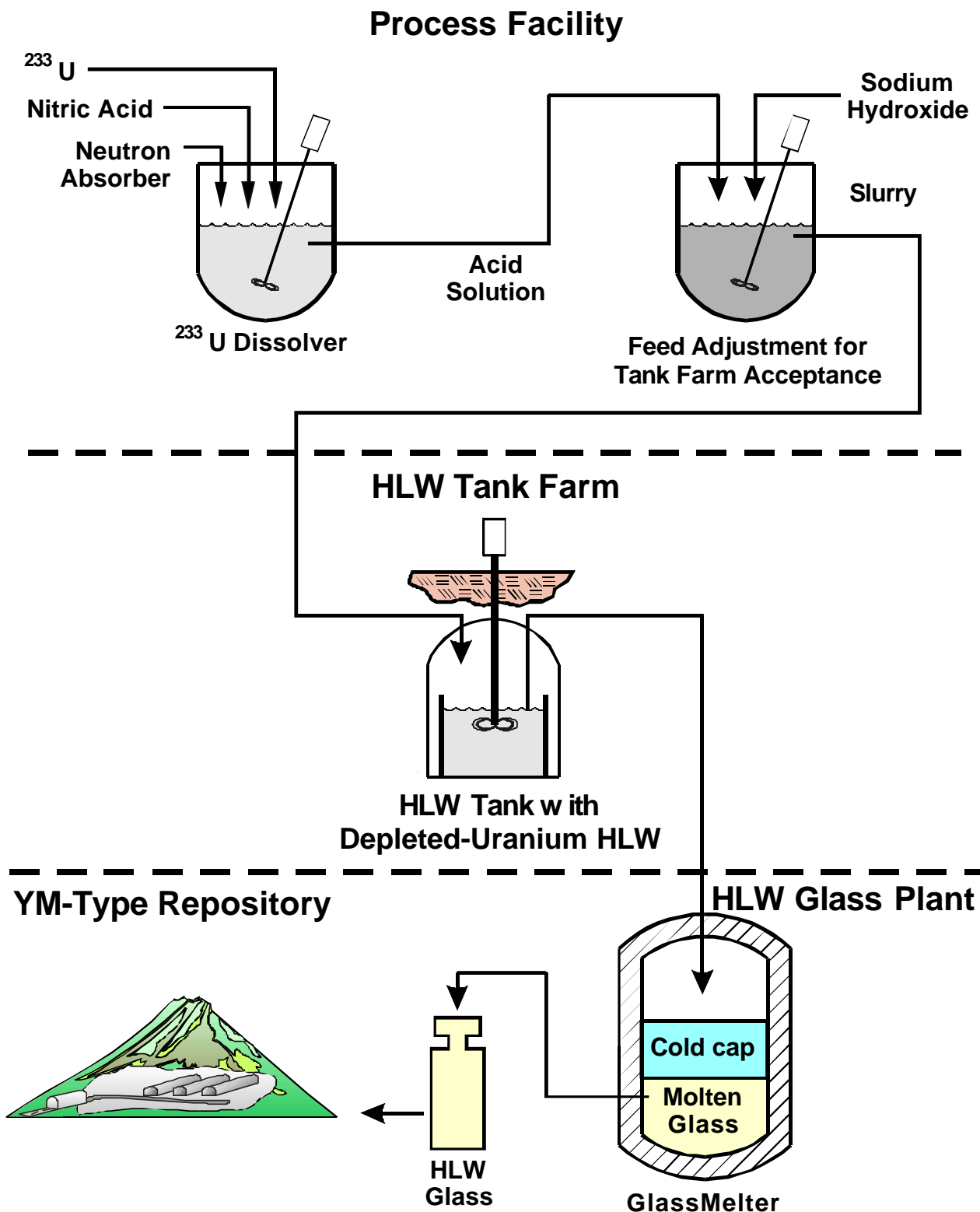

Fig.4.1. Conversion of surplus ²³³U and HLW(containingDU)toHLWglass.

Converting ^{233}U to glass also ensures that all chemical repository waste form criteria are met. Specifically, the CEUSP ^{233}U contains cadmium—an RCRA material. Existing HLW also contain these materials. The HLW glass is designed to accept these materials and produce a chemically nonhazardous glass acceptable to the repository. This implies that removal of cadmium and other neutron absorbers from ^{233}U is not required if it is to be converted to HLW glass.

The option does allow the recovery of ^{229}Th for medical applications before disposal of the ^{233}U . This variant requires adding an ion-exchange column for ^{229}Th recovery between (a) the dissolution step and (b) adjusting the ^{233}U feed for acceptance by the HLW tanks farm.

4.1.2 Suboptions

Within this option, there are a series of suboptions that can impact economics.

- *Waste minimization.* To minimize ^{233}U processing time and, hence, ^{233}U operational costs, it is desirable to add the ^{233}U to the minimum amount of HLW. To minimize HLW glass production, the ^{233}U should be mixed with sufficient HLW sludge such that no clean DU or other neutron absorber for criticality control needs to be added to the waste. Dilution of ^{233}U with added DU or other neutron absorbers is to be minimized because added DU or other neutron absorbers generate added HLW glass logs at a cost of $\$0.5\text{--}2 \times 10^6/\text{log}$ (processing and disposal costs). There is a trade-off between these two strategies to minimize costs. For example, at SRS there are three HLW tanks (26, 33, and 34) with 55,000 kg of DU. The remaining DU is spread over a larger number of tanks. Adding ^{233}U to a small number of tanks is substantially simpler and cheaper than spreading the ^{233}U among many tanks with each tank containing only small quantities of ^{233}U and DU.
- *Mixing options.* There are multiple engineering options for addition of the ^{233}U to the HLW sludge. The mixing can occur in the main HLW feed tank, in the tank farm, or in the smaller process feed tanks in the vitrification facilities. For some equipment options, the ^{233}U may need to be partially diluted with other neutron absorbers or DU to assure that nuclear criticality does not occur during process operations.
- *Feed preparation options.* The ^{233}U to be sent to the HLW tanks could be processed into a form that meets waste tank acceptance criteria using (1) existing facilities such as the canyons near the HLW tanks or (2) prepared elsewhere with direct transfer from a shipping cask to the tank farm. Aqueous processing is the baseline method to prepare feeds to the HLW tanks. However, other processes such as the fusion melt process (Sect. 4.4) may also be used to prepare the feed.

This option, like all co-processing options, does impose schedule constraints on the disposition of ^{233}U . The ^{233}U must be in the tanks when the HLW sludge containing the DU is to be processed. There is a window of time when the option exists at SRS and a second window of time when the option exists at Hanford.

4.1.3 Current SRS Baseline Option

A baseline option (Forsberg October 31, 1997) has been defined for disposition of ^{233}U by mixing with HLW sludge and conversion of the sludge into HLW glass at SRS. The sludge would be converted into HLW glass at the Defense Waste Processing Facility (DWPF)—a facility currently converting HLW sludge to HLW glass. At the Hanford site, a program to convert HLW sludge and liquids into HLW glass is underway; however, it has not progressed to the point where a baseline option can be defined. The defined SRS option consists of the following steps.

- *Dissolution.* The ^{233}U is dissolved into nitric acid. Neutron absorbers (gadolinium nitrate, DU nitrate, etc.) are added, as required, to the solution to eliminate concerns about nuclear criticality during all operations through conversion of the material to HLW glass. The neutron-absorber mixture is chosen to minimize final glass volumes. Much of the existing ^{233}U inventory contains some neutron absorbers (Sect. 2).
- *Chemical adjustment.* The acid solution is neutralized with sodium hydroxide, and the chemistry is adjusted to meet the WAC for the SRS HLW tank farm. The change in pH creates a slurry with any neutron absorbers and the uranium in the solid phase. The slurry has chemical and nuclear properties such that it can be sent to any tank in the tank farm using existing HLW transfer lines and equipment.
- *Transfer to HLW tank.* The slurry is sent to the HLW tanks with high concentrations of DU.
- *Sludge mixing.* The HLW sludge is recovered from the tanks containing the ^{233}U and the DU. The recovery process creates two streams: a sludge and a liquid. The uranium (^{233}U and DU) remains with the sludge. The liquid is separately processed into a LLW stream and a concentrated HLW stream that is mixed with the HLW sludge and sent to a feed tank and then the DWPF for conversion to HLW glass.

To produce high-quality glass, a homogeneous HLW stream must be fed to the DWPF. Each specific HLW glass composition must be qualified to meet waste form acceptance requirements of the repository. Qualifying an HLW glass is a complex operation. The HLW liquids and sludges at SRS are not uniform and vary from tank to tank. To create a uniform, qualified HLW glass, HLW sludges and liquids from up to six HLW tanks may be intermixed to produce a single micro-batch of uniform feed. This batch of feed allows the DWPF to operate up to 3 years producing a single type of qualified HLW glass.

Complex mixing operations and chemical feed adjustments assure a uniform, quality feed for the DWPF. This mixing also assures complete mixing of the ^{233}U with the DU with elimination of the ^{233}U as a weapons-usable material and minimization of long-term criticality issues. A homogeneous, uniform mixture of uranium isotopes in the HLW glass is assured by the requirements to make acceptable HLW glass.

- *Vitrification.* The HLW feed is sent to the DWPF and converted to HLW glass for the geological repository.

For the previous case, it is estimated that 5 L of added HLW glass will be produced per kilogram of ^{233}U . About 1.9 L of glass are produced per kilogram ^{233}U , assuming that the glass density is 2.5 g/cm^3 , the waste loading in the glass is 25 wt %, and the chemical form of the uranium in the glass is equivalent to uranium trioxide (UO_3). In addition, there will be other neutron absorbers and process chemicals. The quantities of these materials are not well defined.

SRS is currently planning to dispose of limited quantities of ^{233}U in its HLW tanks. This establishes some precedent for disposition of larger quantities of ^{233}U in the HLW tanks. The SRS has ~50 kg of irradiated targets containing ~50 g of ^{233}U . It was originally planned to process these targets to recover the ^{233}U . When a surplus of ^{233}U developed, the targets were placed in storage. The targets have degraded with time and were identified in the DNFSB Recommendation 94-1 (May 26, 1994) as a potential safety concern. To address this safety issue, DOE has decided (DOE October 1995; DOE December 12, 1995; and DOE February 8, 1996) to dissolve the targets in nitric acid in 2003, add sodium hydroxide to the solution to create a slurry, and pump the slurry to the tank farm for eventual conversion to HLW glass. Detailed planing for this activity has not yet started.

The basic process for irradiated targets is identical to that proposed for disposition of ^{233}U , but there are differences. The smaller quantity of material allows the addition of large quantities of DU or other neutron absorbers to the dissolver to control nuclear criticality without creating ultimately large additional quantities of HLW glass. For larger quantities of ^{233}U , the economics of HLW glass vitrification create strong incentives to minimize additional HLW glass production. The second difference is that the existing dissolvers in the SRS canyons can be used (without modification) to dissolve the irradiated targets. The SRS facilities were designed and operated to dissolve such irradiated targets. The separated ^{233}U inventory is in a variety of containers—many of which can not be directly fed to the existing SRS equipment. In this context, processing the separated ^{233}U in inventory will either require modification of one of the existing dissolvers or installation of a small special dissolver in one of the hot cells associated with one of the canyon facilities. These issues are further discussed in Appendix C.

4.1.4 Issues

A number of issues have been identified.

- *Schedule.* The HLW option exists only for a limited window of time at SRS and another window of time at Hanford. The ^{233}U must be disposed of when the HLW with the DU is being processed into glass. This may happen within a decade for SRS, but will occur further into the future at Hanford. There is a second schedule issue at SRS. The site is considering shutdown of its canyon processing facilities. Both processing canyons may be closed in the foreseeable future. These facilities can be used for the required acid dissolution step. While special-purpose facilities can be built, there are economic incentives to use existing facilities. The windows of opportunity are currently being defined.

- *Available DU in HLW sludge.* The quantities of DU at SRS are limited. The potential exists for other programs to commit to the use of this resource in disposal of other waste streams. The quantities of DU in sludge at Hanford are very large and, thus, do not appear to be a constraint under any scenario.
- *Technical.* There are several technical issues that must be addressed. It is not currently believed that any of these are a constraint, but some work is required to confirm this. For the SRS option defined previously, it must be confirmed that the gadolinium and ^{233}U will not separate in the chemical operations that occur in the tank farm and DWPF. Criticality control measures must be defined. This impacts final HLW glass volumes. An analysis of dissolver options is also required (Appendix C).

4.2 CONVERT ^{233}U AND DU TO A URANIUM-ALUMINUM ALLOY (STORAGE AND DISPOSAL)

4.2.1 SNF and ^{233}U : Similar Materials and Similar Goals

Aluminum-based SNF is being consolidated at SRS for treatment, packaging, interim storage, and preparation for ultimate disposal. This SNF was discharged from domestic research reactors, foreign research reactors, and SRS production reactors. Much of this SNF contains HEU (SRS April 1997). From a technical perspective, the ^{233}U , which is in stainless steel or aluminum cans, has similarities to the SNF: (1) the primary component is uranium, (2) a clad (can) surrounds the uranium, and (3) some radiation is associated with the material.

Most of the HEU SNF is highly radioactive; thus, there are limited concerns about the potential use of such materials in weapons. However, some of the HEU SNF has low levels of radioactivity, which results in concerns about the potential for recovery of HEU that could be used in weapons. Consequently, DOE (June 1996b) is investigating a melt-dilute process that simultaneously melts aluminum-clad SNF and DU metal to produce a uranium-aluminum alloy suitable for disposal as a waste. Sufficient DU is to be added such as to convert the HEU to LEU and address repository criticality problems. The ^{233}U disposition program has the similar goals: convert excess weapons-usable ^{233}U to nonweapons-usable material and convert any material considered waste into a form acceptable for disposal. The same technology is potentially applicable for ^{233}U disposition. Table 4.2 summarizes this option. Figure 4.2 shows the option.

Table 4.2. Summary: Uranium-aluminum melt dilute option^a

Application	Storage, disposal
Acceptable ²³³ U feeds	CEUSP, clean ²³³ U
Method to convert to non-weapons-usable ²³³ U	Isotopic dilution
Disposal site	YM- and WIPP-type repository
Criticality control strategy	Isotopic dilution
Technical description	Excess ²³³ U, aluminum, and DU metal are melted in a high-temperature furnace to create a uranium-aluminum alloy. The alloy is the final storage or waste form.
Assessment	
Advantages	<p>Potentially a low cost process to convert ²³³U to nonweapons material.</p> <p>The process can dissolve the ²³³U and the packages, thus, avoid unpacking operations. This is particularly desirable for the CEUSP material.</p> <p>WIPP variant may allow future recovery of medical isotopes.</p>
Disadvantages	<p>Process can not treat LWBR ²³³U.</p> <p>The final product volume is significantly larger than with many other process options. This implies increased storage or disposal costs.</p> <p>Viability depends upon results of ongoing research.</p> <p>Costs are uncertain</p>
Evaluation	<p>This is an attractive option if DOE decides to build a facility to treat aluminum HEU SNF. The same facility with little or no modification may be usable for ²³³U disposition. For CEUSP ²³³U, it is uncertain whether the material could go to YM. No leachability tests have been done on uranium-cadmium-aluminum waste forms.</p> <p>It is a potentially competitive stand-alone option to convert ²³³U into an acceptable storage form or for WIPP-type disposal.</p>

^aThe process is being developed for treatment of aluminum-clad SNF for disposal. Uranium-233 could be processed using the SNF facility (if built) or processed in a stand-alone facility.

Melt Metal and Convert Oxides to Metal

²³³UO₂ or other Oxide
(Optional Storage Can Dissolution)

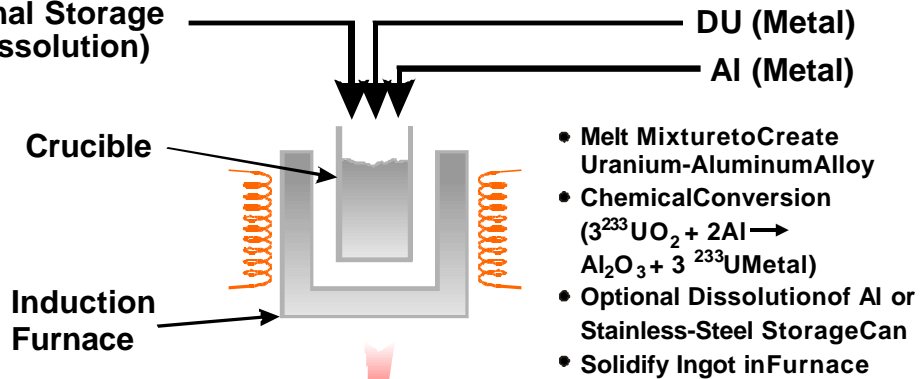

Transfer Ingot to Waste Package and Weld Lid

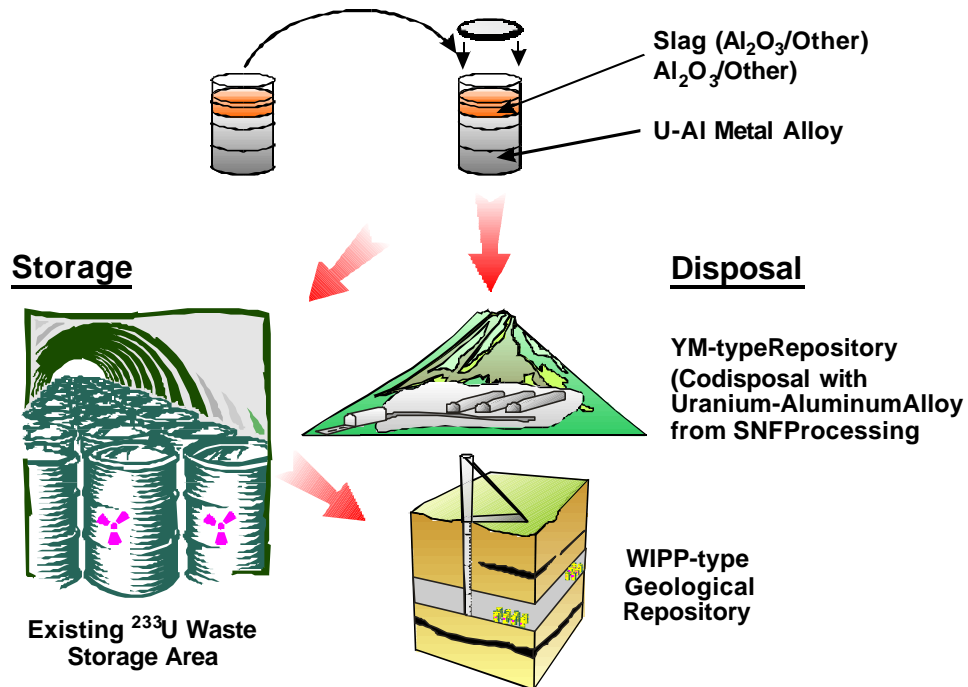

Fig. 4.2. Isotopic dilution of ²³³U with DU in a uranium-aluminum alloy for long-term storage or disposal.

4.2.2 Melt-Dilute Technology

The melt-dilute technology is currently under development at SRS (April 1997) for processing aluminum-clad SNF. The draft SRS Spent Nuclear Fuel Management Environmental Impact Statement (DOE December 1998c) identifies it as the preferred management option for this SNF. The technology, without modification, can be used to isotopically dilute ^{232}U for long-term storage or prepare a waste form for disposal. Initially, the incoming SNF or ^{233}U is characterized to determine its uranium content. This data would be used to determine the amount of DU needed to dilute the HEU or ^{233}U to make the material non-weapons-usable and to address nuclear criticality issues.

The SNF element or ^{233}U would be placed in a crucible and melted. DU (in the form of a metal) and aluminum would be added to the crucible. The final product would be 9 to 67 wt % uranium in the uranium-aluminum alloy.

If the uranium is in the oxide form, it reacts with the aluminum metal to form a uranium-aluminum alloy and a slag of aluminum oxide floating on top of the melt. For example, if the feed contains U_3O_8 , the following chemical reaction is expected to occur (Adams, Peacock, and Rhode September 9, 1998):

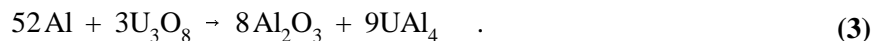

This chemistry allows for the processing of aluminum-clad SNF containing oxides and ^{233}U in oxide form. However, studies have also shown that the chemical kinetics of oxide conversion in aluminum are slower than for metallic uranium. By addition of elements such as calcium, the oxide is readily reduced and dissolution becomes rapid. Almost all the ^{233}U in inventory is in the form of oxides.

Three final alloy compositions are being studied at SRS for the uranium-aluminum alloy: 13.2, 30, and 67 wt % uranium. The final densities of these compositions are about 3.02 g/cm^3 (measured), 3.64 g/cm^3 (estimated), and 6.36 g/cm^3 (estimated), respectively. The uranium-aluminum phase diagram is shown in Fig. 4.3. The 13.2 wt % composition is the eutectic for the mixture, which results in the lowest melting point (about 600°C). This composition is currently the preferred option for aluminum-based SNF melting; however, additional studies are required before a final determination can be made. The other two mixtures have higher melting points: about 1000°C for the 30 wt % mixture and about 1500°C for the 67 wt % mixture.

The final alloy composition will represent a trade-off between the operating temperature to melt the alloy, the final solidified volume of the alloy, and performance of the alloy as a waste form. As DU is added, the uranium composition will increase, thereby increasing the required temperature to maintain the liquid form (see Fig. 4.3). If SNF is being processed, increased temperatures will drive more fission products into the off-gas system during processing. Hence, the operating temperature will dictate the design of the off-gas system. On the other hand, if aluminum is added to maintain the composition nearer to the eutectic mixture, then the required temperatures will be lower. However, these lower temperatures will be offset by a higher final volume of the alloy. The ongoing studies of the three proposed compositions will provide insight into the optimum final composition.

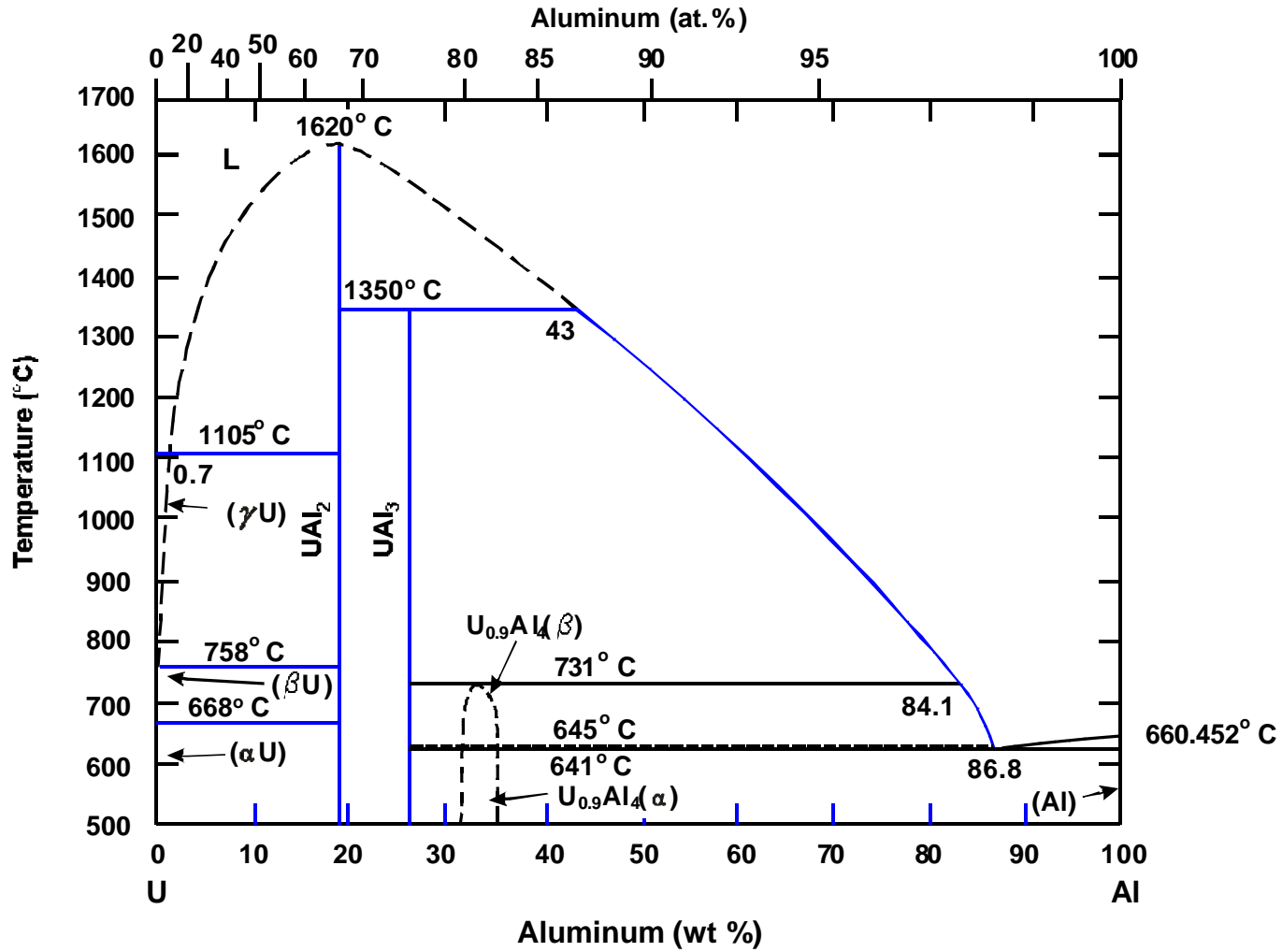

Fig.4.3.Uranium-aluminum phasediagram.

Fig 4.3. Uranium-aluminum phase diagram.

When the desired final composition of the melted uranium-aluminum alloy has been reached, then the molten alloy can either be solidified in the crucible or poured into a mold. The solidified form can then be sealed and placed in dry storage. Canisters containing the diluted alloy will then eventually be shipped to a geologic repository for disposition.

The alternative uranium-aluminum alloy product compositions are presented in Table 4.3. Two cases are shown for the dilution of the ^{233}U with DU. For the first case, it is assumed that the material is isotopically blended down to nonweapons material. For 1 kg ^{233}U , 7.407 kg of 0.2 wt % DU would be required. In the second case, it is assumed that the material is isotopically blended down to eliminate long-term nuclear criticality concerns. For 1 kg ^{233}U , 188 kg of 0.2 wt % DU would be required. (Note that in both cases, the amount of DU required accounts for the amount of ^{235}U in the DU.)

Table 4.3. Specific volume and mass of the final uranium-aluminum alloy for different products for an initial 1 kg ^{233}U

Composition of alloy (wt % uranium)	Specific volume of alloy (L/kg ^{233}U)		Mass of alloy (kg/kg ^{233}U)	
	Nonweapons ^a	Critically safe ^b	Nonweapons ^a	Critically safe ^b
13.2	21	474	64	1,432
30	8	173	28	630
67	2	44	13	282

^aDilution of the ^{233}U to a nonweapons enrichment (~12 wt % ^{233}U in ^{238}U).

^bDilution of the ^{233}U to eliminate criticality concerns (~0.53 wt % ^{233}U in DU with 0.2 wt % ^{235}U).

The ^{233}U that is already contained in aluminum packages should be acceptable for co-processing with the aluminum-based SNF. The remainder of the ^{233}U which is packaged in steel/stainless steel containers could be repackaged into aluminum containers. Alternatively, it may be possible to process these materials directly without repackaging because stainless steel is soluble in aluminum alloy mixtures. Further study of the chemistry may allow such an option.

Initial testing of the melt-dilute technology is currently being performed at SRS to determine the viability of the process (Barlow September 9, 1998; Peacock, Adams, and Iyer September 9, 1998; Adams, Peacock, and Rhode September 9, 1998; Krupa September 9, 1998). Further tests will be conducted to determine if the performance of the final waste form is acceptable. An economic (DOE December 1998*a*), nonproliferation impact assessments (DOE December 1998*b*), and a draft EIS (DOE December 1998*c*) have been recently completed on the process and the program. It is expected that by mid 1999, DOE will decide whether to proceed to engineering design of the melt-dilute technology.

4.2.3 Uranium-233: Specific Uranium-Aluminum Alloy Issues and Options

4.2.3.1 Other Chemical Species

This option is technically suitable for clean and CEUSP ^{233}U . The option is not viable for the LWBR ^{233}U . In the process, uranium oxides are converted to metal by a chemical reaction with aluminum metal. The LWBR material contains ~350 kg of $^{233}\text{UO}_2$ in about 14 t of ThO_2 . Unfortunately, aluminum will not convert ThO_2 to thorium metal with subsequent dissolution of the thorium metal in the aluminum metal. The ThO_2 is thermodynamically more stable than Al_2O_3 . Unless the thorium is converted to metal, the aluminum can not reach the $^{233}\text{UO}_2$ inside the ThO_2 matrix to convert it to metal and dissolve it into aluminum.

Consideration is being given to recover ^{229}Th from the clean and CEUSP ^{233}U for medical purposes. The same process chemistry that prohibits use of this process on LWBR ^{233}U may allow recovery of ^{229}Th from the clean and CEUSP ^{233}U inventories when the ^{233}U is being isotopically diluted with DU. In these two feeds, the thorium content is measured in parts per million ^{229}Th —not natural thorium ^{232}Th . Because of these low thorium concentrations, the uranium-aluminum process will work. However, the thorium will remain as an oxide. As the ^{233}U oxides are converted to uranium metal producing aluminum oxide, it would be expected that the thorium oxide would be incorporated into the aluminum oxide to produce a slag on top of the metal alloy. The thorium can be recovered from this slag. No process experiments have been done, so the efficiency of recovery is unknown.

The CEUSP ^{233}U contains significant quantities of gadolinium oxide (Gd_2O_3) and cadmium oxide that were added to assure criticality control. The cadmium oxide is expected to be reduced to metal (Chellew and Bennett 1961). Some fraction of the cadmium will volatilize into the off-gas system. The fraction of the cadmium to the off-gas system is strongly dependent upon the chosen operating temperature. The Gd_2O_3 may remain as an oxide (Chellew, Bennett, and Trice 1961) and would be expected to float to the top of the melt and form a slag with other oxide materials.

4.2.3.2 Direct Processing of CEUSP ^{233}U Containers

The packaging of the CEUSP ^{233}U presents significant problems. The ^{233}U is in the form of an oxide monolith that is integral with the container; i.e., if the container is cut open, the uranium oxides do not flow out of the container but rather remain attached to the walls. For most options, the uranium oxide will have to be mechanically removed from the storage cans—a complex mechanical process. The aqueous (Sect. 4.3) and borate fusion melt (Sect. 4.4) processes can dissolve the uranium oxides out of the storage cans. The uranium-aluminum alloy process creates the unique option of dissolving the stainless steel can and the uranium within the can. This simplifies front-end processing.

Studies at SRS indicate that both 304 and 316 stainless steel dissolve in molten aluminum with the dissolution rate increasing rapidly with temperature. Carbon steel—a potential crucible material—does not dissolve into molten aluminum. Development tests would be required to determine if a practical process could be developed to dissolve the ^{233}U and its storage can.

4.2.3.3 Product Volumes

There is one well-understood disadvantage to the uranium-aluminum melt options. The product volumes are greater than for most other process options. The aluminum results in a lower uranium density final product. The volumes can be reduced by producing a higher uranium content alloy but this does require higher process temperatures with the expected complications. This volume factor is an issue for ^{233}U disposition but it is not an issue for SNF disposition. Aluminum-clad HEU SNF has a large number of cooling channels. If the SNF is melted into a monolithic ingot with added DU, the final volume is still considerably smaller than the original SNF.

4.2.3.4 Option Variants

There are several uranium-aluminum alloy storage and disposition variants. The success of the SNF program will determine which options are potentially viable for ^{233}U disposition. There are three technical challenges for the SNF program: (1) develop a workable uranium-aluminum melt process, (2) develop an off-gas system for the fission products from melting SNF, and (3) qualify the uranium-aluminum alloy for disposal at YM. If the R&D is successful, a decision can then be made on whether to build a facility. The ^{233}U variants are:

- *Use SNF facility.* If the SNF R&D program is successful and a decision is made to build an SNF process facility; then, the same facility may be used to process ^{233}U and dispose of the waste at YM.

There is an additional uncertainty associated with CEUSP ^{233}U if the final product is sent to YM. The proposed YM repository does not accept RCRA (chemically hazardous) wastes. There is a U.S. Environmental Protection Agency (EPA) test that determines whether a particular waste is chemically hazardous (i.e., an RCRA waste). No such testing has been done with uranium-aluminum-cadmium waste forms.

- *Build ^{233}U process facility and dispose of waste at YM.* If the R&D program is fully successful, the option exists to build a separate facility for ^{233}U disposition. This may be a practical option because a ^{233}U uranium-aluminum process in an existing facility would cost a small fraction of what an SNF treatment facility would cost. SNF treatment with this process implies a costly facility because melting SNF releases volatile fission products to the off-gas system. This, in turn, requires development of a complex and an expensive off-gas system. This is the major facility cost. With ^{233}U , there does not exist a high-volume, expensive-to-treat, corrosive off-gas.
- *Build ^{233}U process facility and send the product to storage or dispose of the material as a waste at a WIPP-type facility.* If the final waste form is not fully qualified for YM, the option is to send the waste to a WIPP-type facility. The existing data indicate that the uranium-aluminum alloy would meet WIPP WAC. The presence of cadmium in the CEUSP ^{233}U would not be an issue since RCRA materials are accepted in WIPP-type facilities.

4.2.4 Conclusions

The SRS R&D program has demonstrated the basic uranium-aluminum melt process. The initial experiments have been successful. Significant work remains to develop an acceptable off-gas system for SNF (Howell and Zino September 9, 1998; Hodges and Hyder September 9, 1998). Difficulties have been encountered in qualifying the waste form for YM (Duguid et al. September 10, 1998; Louthan, Wiersma, and Mickalonia September 10, 1998; Lam, Sindelar, and Peacock September 10, 1998).

If the technology were successfully developed, it would be applicable for the isotopic dilution of ^{233}U with DU for storage or disposition of excess ^{233}U . There is one exception, the option can not process LWBR ^{233}U . There are several variants. The viable variants depend upon the success of the SNF R&D program and SNF programmatic decisions.

4.3 AQUEOUS BLENDING OF ^{233}U WITH DU (STORAGE AND DISPOSAL)

4.3.1 Characteristics of Aqueous Option

The aqueous nitrate blending process can be used to convert ^{233}U into nonweapons material for long-term storage or into a waste form meeting all technical requirements for disposal at a YM- or WIPP-type facility. The option is summarized in Table 4.4 and shown in Fig. 4.4. It is the most versatile ^{233}U process and is the historical process used to purify and produce various ^{233}U compounds. It allows the option of recovery of thorium isotopes for medical purposes. It also allows separation of thorium or cadmium compounds from the feed to produce desired storage or disposal forms for ^{233}U -containing materials. Multiple storage or waste forms can be produced.

Table 4.4. Summary: Aqueous nitrate blending of ^{233}U with DU

Application	Long-term storage and disposal
Acceptable ^{233}U feeds	All
Method to convert to non-weapons-usable ^{233}U	Isotopic dilution
Disposal site	YM-type repository, WIPP-type repository
Criticality control strategy	Isotopic dilution
Technical description	Excess ^{233}U is codissolved with DU in nitric acid and converted to the desired product or waste. The process can produce multiple storage and waste forms.
Assessment	
Advantages	<p>This is the only demonstrated technology.</p> <p>The process can produce different storage and waste forms.</p> <p>The process allows recovery of medical isotopes and removal of troublesome impurities.</p>
Disadvantages	<p>The process is potentially more expensive than other options.</p> <p>No existing facility is currently capable of this type of processing. Facility modifications would be required.</p>
Evaluation	<p>This is the historical, standard, industrial process for ^{233}U. No existing facility is set-up to process existing inventory. Facilities at ORNL, SRS, or INEEL could be modified to do this type of processing.</p>

Dissolver

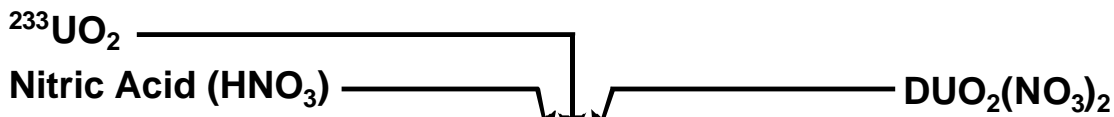

Separations (Optional)

- Th Recovery
 - ^{229}Th (medical)
 - Th(LWBR)
- Purification
 - Cd Removal
 - Decay Products

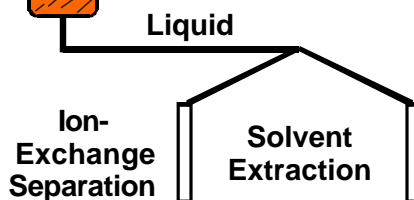

**Thermal Denitration/
Consolidation**

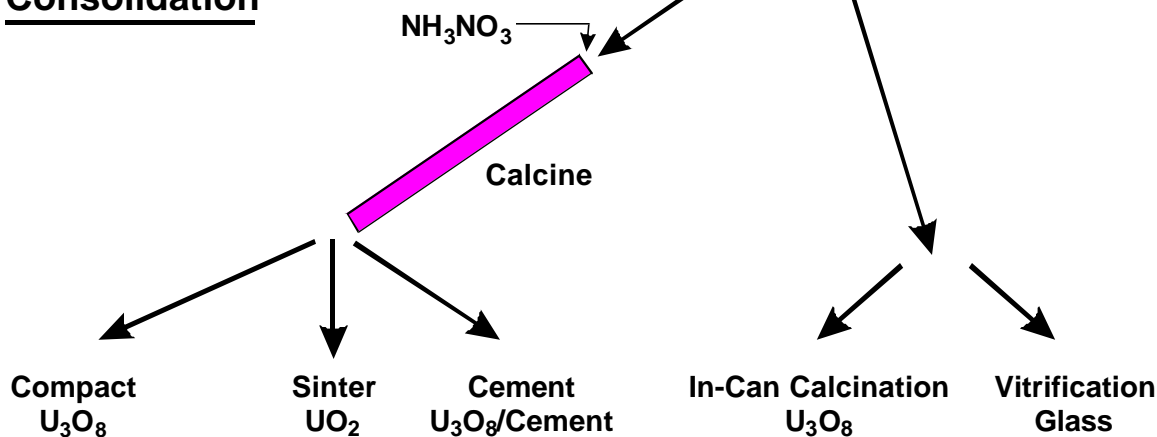

Disposal

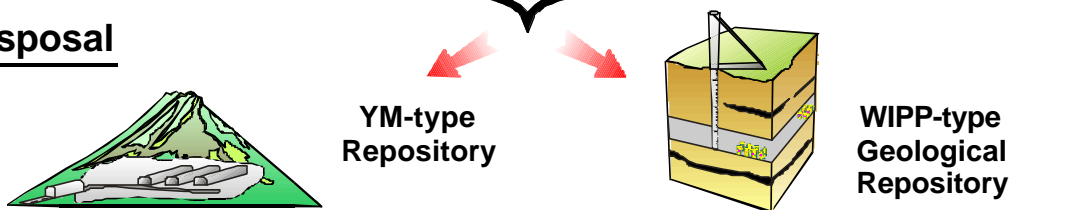

Fig. 4.4. Aqueous processing option for ^{233}U long-term storage or disposal.

In the aqueous nitrate blending process (ORNL July 13, 1995b), solid ^{233}U material is dissolved in nitric acid to produce an aqueous uranyl nitrate solution, which is mixed with a uranyl nitrate solution of DU. After mixing, the solution is denitrated (by heating) to form an oxide powder from which the ^{233}U cannot be separated from the ^{238}U without isotopic enrichment. The powder may be either pressed into pellets or incorporated into grout to provide an acceptable form for transport and disposal. Alternatively, the solution may also be denitrated in the storage can to produce an oxide monolith similar to the CEUSP ^{233}U monoliths. If desired, thorium, cadmium, and other impurities in the ^{233}U feed can be removed by adding a purification step after acid dissolution. A schematic flowsheet for the process is shown in Fig. 4.5.

4.3.2 Process Description

Uranium-233 material is lifted from the storage well into a shielded cask, which is then transported to the loading port at the manipulator hot cell. Processing the material is carried out on a batch basis to control criticality and inventory. After inspection and inventory, the containment vessels are opened, and the contents are removed. Equipment is provided for cutting the cans open. The material can be removed by mechanical means or by direct acid dissolution of the material in the can (Appendix B).

Granular or powdered material containing 1 kg ^{233}U is converted to a uranyl nitrate solution by reaction of about 3 L of 4 M nitric acid per kilogram of U (as oxide) to produce ~330 g U/L of solution. A uranyl nitrate solution of DU of the same concentration is prepared by the reaction of DU oxide (U_3O_8) with nitric acid outside the hot-cell area. Dissolution of the thorium oxide- ^{233}U oxide fuel currently stored at INEEL will require the addition of hydrofluoric acid and aluminum nitrate to the nitric acid to aid in dissolution. After acid dissolution, the option exists to remove useful medical isotopes, cadmium, thorium, or other impurities from the feed. The standard processes for these separations are ion exchange and solvent extraction.

Blending is done by mixing measured amounts of ^{233}U nitrate solution and depleted uranyl nitrate solution to produce controlled isotopic concentrations of uranium. To produce a free-flowing powder during denitration, 2 mol of ammonium nitrate per mole of uranium is mixed with the uranyl nitrate solution during the blending step (the modified direct denitration process).

A one-step conversion of the blended uranyl nitrate solution to uranium trioxide (UO_3) is accomplished by thermal denitration in a rotary kiln. The process produces a free-flowing fluffy powder. The powder has a low density (about 1 g/cm³) and is in a form that might be easily dispersed. Several methods are available to consolidate the material to a safer monolithic storage form (Table 4.5). The powder can be compacted to 4.3 g/cm³ (about 60% of the theoretical density of UO_3) to produce a nondusty, monolithic form. If desired, the compacted material can be sintered to form higher-density uranium dioxide like the dry-powder blend process. Alternatively, the oxide may be incorporated into a cement grout at a 50 wt % loading.

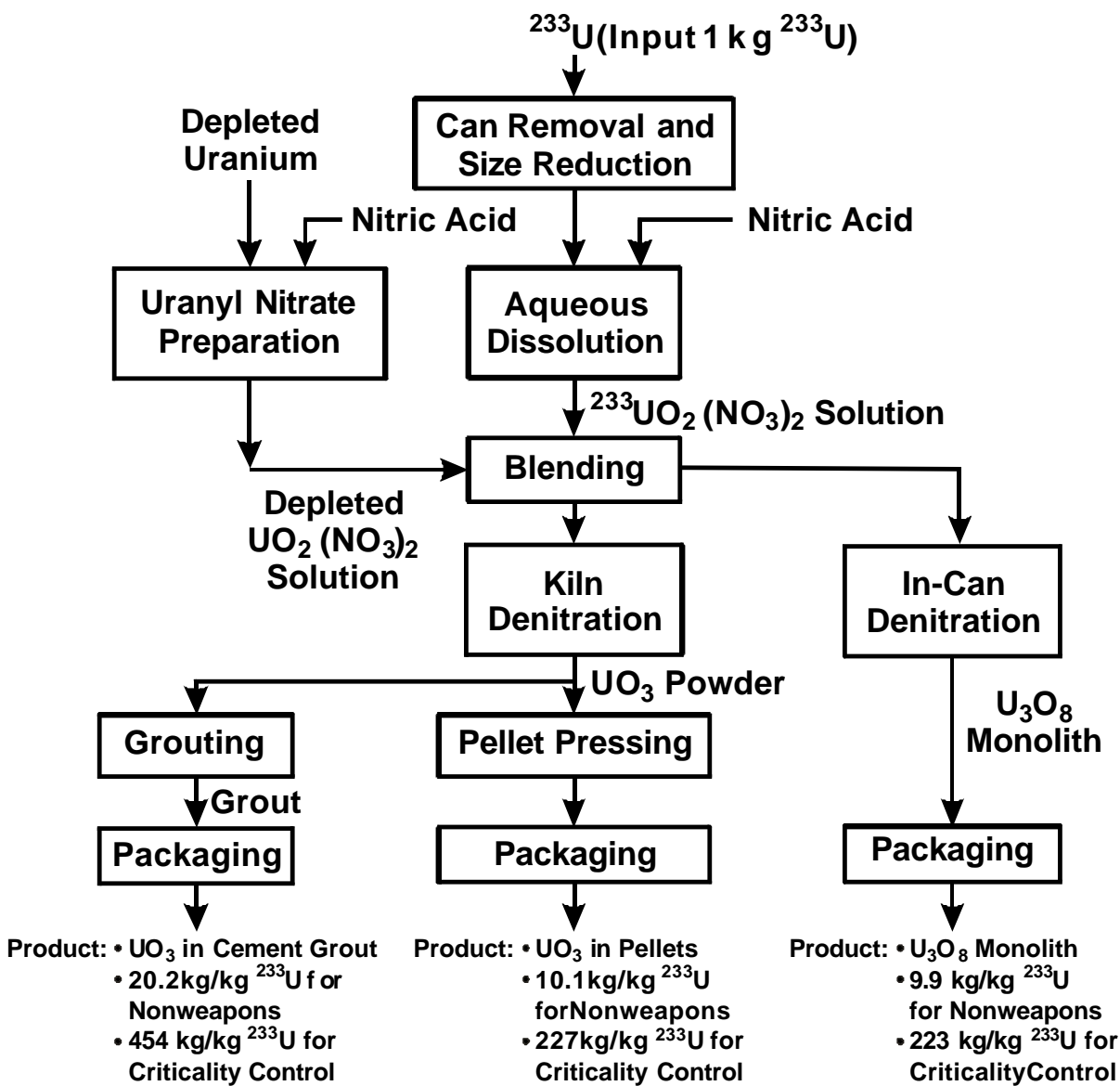

Fig.4.5. Isotopic dilution by the aqueous-nitrate-blending process.

Table 4.5. Product volume and mass per kilogram of ²³³U for aqueous processing

Processing option	Volume (L/kg ²³³ U)		Mass (kg/kg ²³³ U)	
	<12 wt % ²³³ U	<0.67 ^a wt % ²³³ U	<12 wt % ²³³ U	<0.67 ^a wt % ²³³ U
Pellets (UO ₃)	2.3	52.8	10.1	227
Sintered pellets (UO ₂)	0.96	21.7	9.5	214
Grout	4.8	108.2	20.2	454
In-can denitration (U ₃ O ₈)	3.1	67.5	9.9	223

^aThe required isotopic dilution for criticality control is 0.66 wt % ²³³U in pure ²³⁸U. If DU with 0.2 wt % ²³⁵U is used, the final concentration of ²³³U is 0.53 wt %. Some of the ²³⁸U must be used for criticality control of the ²³⁵U in the DU.

Other process options exist to solidify the liquid uranyl nitrate solution. An immobilized oxide can be produced by denitrification of the blended uranyl nitrate solution in the product can (similar to that done for the CEUSP material and described in Appendix C). Using this method, ammonium nitrate would not be added to the nitrate solution. The solution is slowly dripped into the product can that is in a vertical tube furnace at a temperature of ~800 °C. At these conditions, the water is driven off, and the resultant uranium nitrate is decomposed to produce a U₃O₈ monolith product. This solidification process may be simpler to implement on a small scale. The liquid solution may also be fed to a glass melter to produce a uranium glass. This is a variant of the HLW glass disposition option. The products from any of the immobilization methods are packaged in doubly contained vessels with welded seals for transport and disposal.

All of the uranium oxides would be expected to be acceptable for long-term storage. There are some technical uncertainties associated with the grout because of the possibility of generation of hydrogen from ²³³U alpha radiolysis. All of the uranium oxides would be acceptable for disposal in a WIPP-type facility. All of the uranium oxides would likely be acceptable for disposal in a YM-type facility; however, high-fired uranium dioxide would probably be preferred. The proposed YMR is designed to accept 63,000 metric tons of initial heavy metal SNF in the form of uranium dioxide pellets in metal tubes. There will be fewer issues associated with a waste form that is chemically identical to the primary waste form expected at the repository.

The aqueous process can produce several alternative final products with different volumes and masses. Isotopic dilution of 1 kg of ^{233}U to non-weapons-grade uranium by the aqueous-nitrate-blending process will produce 10.1 kg of UO_3 (8.407 kg U) as pellets having a volume of 2.3 L. Grouting the oxide will produce 20.2 kg of material having a volume of 4.8 L. In-can denitration will produce 9.9 kg of U_3O_8 product having a volume of 3.1 L. Blending 1 kg of ^{233}U to eliminate long-term criticality will produce 227 kg of UO_3 pellets (189 kg U) having a volume of 52.8 L. Incorporation of the oxide into grout will produce 454 kg of grout with a volume of 108.2 L/kg of ^{233}U . Denitrification of the blended nitrate solution in the product can will produce 223 kg of U_3O_8 having a volume of 67.4 L. The actual waste volume per kilogram of ^{233}U will be higher in many cases because other materials present in some of the ^{233}U feeds (thorium oxide, cadmium oxides, gadolinium oxides, etc.). Actual volumes may vary depending upon the specific process conditions chosen.

4.4 FUSION-MELT BLENDING (STORAGE AND DISPOSAL)

Uranium-233 and DU can be converted to glass by dissolution of uranium oxides into molten glass formers in a high temperature furnace. The product is a non-weapons-usable glass suitable for long-term storage or disposal at a YM- or WIPP-type facility. Glass production is a trade-off between processability (furnace temperature, dissolution time, etc.), glass durability, and high waste loadings. There are two process variants; one chosen to minimize costs (Table 4.6; Fig. 4.6) and the other chosen to produce a high quality waste glass that would meet YM-type waste form requirements (Table 4.7; Fig. 4.7).

The first variant is a borate fusion melt wherein the glass former [boron oxide (B_2O_3) or borax ($\text{Na}_2\text{B}_4\text{O}_7$)] is chosen to minimize processing costs and maximize uranium loadings in the final product. It can be used to isotopically dilute ^{233}U oxides with DU oxides and create a solid borate fusion melt suitable for long-term storage or disposal at a WIPP-type facility. The product would not be acceptable for a YM-type facility unless the borate was removed in a subsequent processing step. The process could be used to dilute ^{233}U to 12 wt % ^{233}U in ^{238}U (nonweapons ^{233}U) that is stored for potential future use. The product characteristics would allow relatively simple recovery of uranium or decay products such as ^{229}Th (for medical applications) at a later date. The process may also be used as a pretreatment step for ^{233}U disposal in HLW glass (Sect. 4.1). Product characteristics are shown in Table 4.8.

The high-quality glass fusion melt process can accomplish the same tasks and produce a waste form acceptable for a WIPP- or YM-type repository. High-quality waste glasses (typically with high silica contents) require more complex processes and have significantly lower concentrations of uranium in the product. This process would not be suitable for dilution of ^{233}U to 12 wt % ^{233}U in ^{238}U (nonweapons ^{233}U) that is stored for potential future uses because of the difficulty in recovery of uranium from such a glass. Product characteristics are shown in Table 4.8.

Table 4.6. Summary: Convert ^{233}U to borate fusion melt

Application	Storage, disposal
Acceptable ^{233}U feeds	All
Method to convert to non-weapons-usable ^{233}U	Isotopic dilution
Disposal site	WIPP-type repository
Criticality control strategy	Isotopic dilution
Technical description	Excess ^{233}U and DU oxides are dissolved in borates [boron oxide (B_2O_3) or borax ($\text{Na}_2\text{B}_4\text{O}_7$)] in an induction furnace to create a fusion melt. The melt is cooled to a solid and packaged.
Assessment	
Advantages	<p>Potentially the simplest, lowest-cost option to isotopically dilute ^{233}U oxides with DU oxides.</p> <p>Can dissolve uranium oxides from sliced CEUSP storage containers.</p> <p>Product form would allow future recovery of the isotopically diluted ^{233}U or potentially valuable decay products (^{229}Th for medical applications).</p> <p>The process may also be used as a feed preparation step to prepare ^{233}U for disposal in HLW tanks (see Sect. 4.1).</p>
Disadvantages	<p>Low-quality waste form (boron oxide soluble in water) suitable for disposal in a WIPP-type facility, but not in a YM-type facility.</p> <p>Some additional process development work required.</p>
Evaluation	This is a viable option and may be the low cost option if isotopic dilution is the primary requirement. There is the potential to modify the process to produce a better waste form.

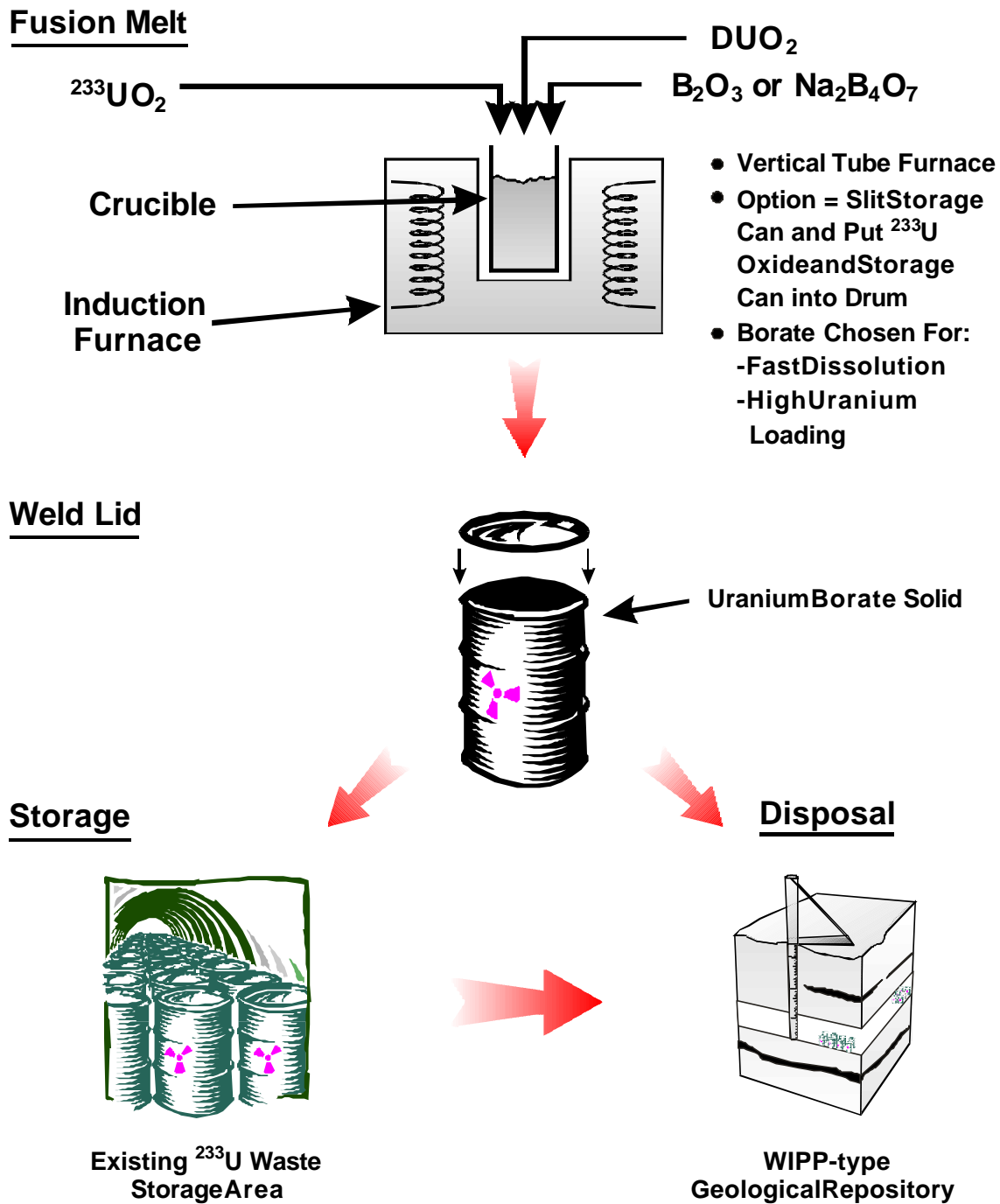

Fig.4.6. Borate-fusion melt for ^{233}U long-term storage or disposal.

Table 4.7. Summary: Convert ^{233}U to glass by fusion melt

Application	Storage, disposal
Acceptable ^{233}U feeds	Clean and CEUSP materials. LWBR ^{233}U as a feed may be unacceptable because of its thorium content.
Method to convert to non-weapons-usable ^{233}U	Isotopic dilution
Disposal site	WIPP- and YM-type repository
Criticality control strategy	Isotopic dilution
Technical description	Excess ^{233}U and DU oxides are dissolved into a molten glass frit (metal oxides) in an induction furnace to create a fusion melt. The melt is cooled to a solid and packaged.
Assessment	
Advantages	Final waste form is acceptable for any disposal site. High confidence that process will work based on HLW glass making experience.
Disadvantages	Waste form development is required to develop high-uranium waste glass that meets YM WACs. Uranium loadings in the glass strongly impact process and disposal cost. Process development work is required. It is unclear whether a practical thorium glass with high waste loadings can be developed.
Evaluation	This is a viable option because of the large experience base that exists with glass waste forms. There are major cost uncertainties. These uncertainties derive from two technical uncertainties: (1) maximum allowable uranium and thorium loading in the glass and (2) chemical reaction rates between glass frit and the uranium.

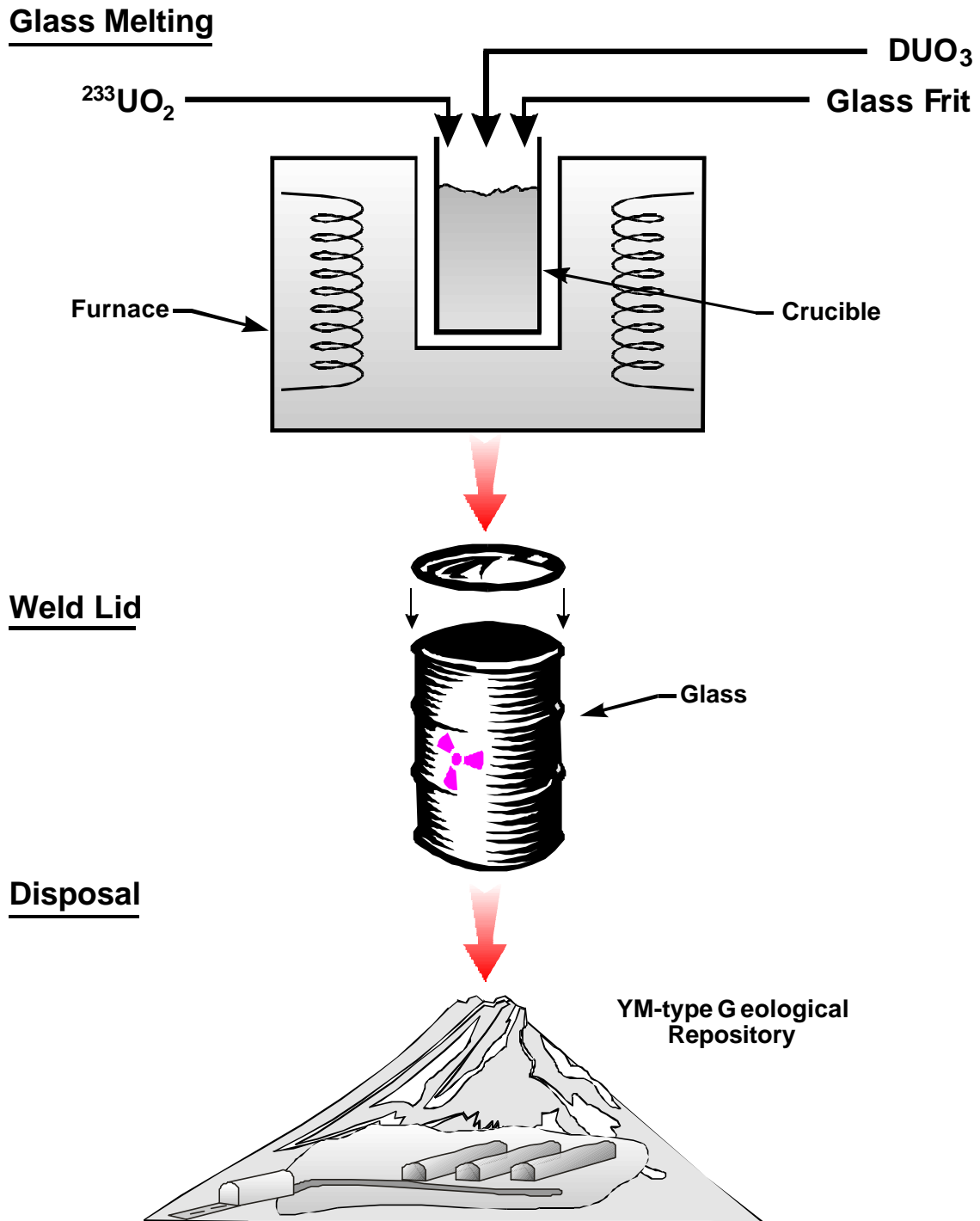

Fig.4.7. Glass-fusion melt (alkali glass) option for disposition of ^{233}U .

Table 4.8. Product volume and mass per kilogram of ^{233}U

Processing option	Volume (L/kg ^{233}U)		Mass (kg/kg ^{233}U)	
	<12 wt % ^{233}U	<0.67 ^a wt % ^{233}U	<12 wt % ^{233}U	<0.67 ^a wt % ^{233}U
Boron oxide ^b	1.98	44.6	12.5	282
Quality glass	5.0	115.5	19.8	446

^aThe required isotopic dilution for criticality control is 0.66 wt % ^{233}U in pure ^{238}U . If DU with 0.2 wt % ^{235}U is used, the final concentration of ^{233}U is 0.53 wt %. Some of the ^{238}U must be used for criticality control of the ^{235}U in the DU.

^bThe B_2O_3 fusion melt is assumed to be 80 wt % UO_3 and 20 wt % B_2O_3 . The respective densities of B_2O_3 , UO_3 , and a fusion melt with 80 wt % UO_3 (estimated) are 2.46 g/cm³, 7.29 g/cm³, and 6.32 g/cm³.

4.4.1 Process Descriptions

In all fusion melt processes (ORNL July 27, 1995), the ^{233}U oxide is mixed with DU oxide powder and solvent metal oxide powder and melted in an induction furnace to produce a material in which the ^{233}U cannot be separated from ^{238}U by chemical or mechanical means. The solvent metal oxide dissolves the uranium oxide into a molten solution. The use of solvent oxides reduces fusion melt temperatures from 2,500 °C for pure UO_2 to temperatures between 800 and 1,200 °C. In a borate fusion melt process, the solvent metal oxide is B_2O_3 or $\text{Na}_2\text{B}_4\text{O}_7$. Other oxides may be added to lower glass viscosities and, thus, operating temperatures. The loading of uranium oxides may exceed 80 wt %. In the glass fusion melt process, a glass frit containing alkali oxides and silica is used to produce a high-uranium-content glass with uranium oxide loadings up to 50 wt %.

4.4.1.1 Glass Fusion Melt Process Description

The glass fusion melt process is shown in Fig. 4.7. The ^{233}U material to be processed is removed from the storage wells and transported in a shielded carrier to the processing hot cell. The material is then processed in limited-sized batches for criticality control. Inside the hot cell, the material is inventoried for accountability control. After inventory measurements, the containers are opened, and the contents are removed. Many of the containers, such as the CEUSP monoliths, require equipment to cut open the

container and to drill into it or otherwise to extract the contents. After any large chunks are removed from the containers, the chunks are crushed into granules before the material is sent to a ball mill to be powdered. Any of the oxide forms in which the uranium is stored (UO_2 , U_3O_8 , etc.) can be used. Metallic uranium and low-oxide uranium may require conversion to oxide (U_3O_8) before blending. If so, this is affected by heating the uranium in a furnace under an air or steam atmosphere. The nominal processing rate is 1.2 kg of fissile uranium per day, assuming a three-shift-per-day operation and a 4-h cycle per batch using one melt-blend furnace. However, the processing rate could be increased by installing parallel systems.

After the ^{233}U material is converted to an acceptable powder form, it is blended with DU and a specified solvent oxide mix consisting largely of alkali-metal oxides and silica. Since the melt-product crucible also serves as the product container, it should be sized for the final product volume. As such, the crucible will not hold all of the material in loose, flowable, powder form. Several powder additions must be made during the processing of a single batch of material. The initial charge does not contain the DU. With the onset of melting, DU oxide is periodically added while the mix is stirred. The final process temperature will be adjusted to achieve complete melting for the type ^{233}U product glass being processed. No significant chemical reactions occur during mixing and melting other than dissolution of the uranium oxide. The isotopic content of the mix is verified by sampling. After the contents are melted and mixed, the furnace is turned off, and the contents are allowed to solidify in the melt crucible.

To provide double containment for storage and shipment, the crucible containing the product is sealed inside an inner container by welding. The inner container is then placed inside a second container, which is also sealed by welding.

The glass fusion melt process adds alkali-metal oxides, silica, and DU to final product. The isotopic dilution of 1 kg of ^{233}U to non-weapons-grade uranium by the dry melt process will produce ~19.8 kg of oxide product (containing 8.407 kg of U and 9.9 kg of alkali metal oxide and silica) having a volume of 5 L. Blending 1 kg of ^{233}U to eliminate long-term criticality will produce 446 kg of oxide (189 kg U as U_3O_8 and 214.4 kg of alkali metal oxide and silica) with a volume of 115.5 L. The actual waste volume per kilogram of ^{233}U will be higher for those feeds containing impurities (thorium oxide, cadmium, and gadolinium oxides). Some impurities, such as thorium, may significantly increase waste volumes because of solubility limits of these impurities in glass.

4.4.1.2 Boron-Oxide Fusion Melt

The boron-oxide fusion melt process is similar—except that some steps may be simplified, melting times may be reduced, and waste loadings may be increased. This follows from choosing a metal oxide solvent based on its properties to dissolve uranium oxides quickly at relatively low temperatures (which

minimize off-gas complications) rather than choosing a metal oxide solvent based on glass performance requirements. The option may minimize or eliminate the need to grind the ^{233}U feed materials. Second, the process may be applicable to LWBR ^{233}U . Thorium oxide is not readily soluble in traditional glasses. It is an option herein. In this context, the ThO_2 concentration will be low in the final product because of the addition of large quantities of DU.

As a part of several programs in Germany and the United States to develop chemical core catchers for nuclear power reactors, significant work (Dalle Donne et al. 1978; Forsberg et al. 1997) has been done on the dissolution of uranium oxides in different borates. Core-melt accidents are among the most serious nuclear reactor accidents. In a serious accident, the core itself melts, then melts a hole through the pressure vessel, and next melts a hole through the building containment floor that allows release of radioactivity to the open environment. Core-melt accidents are difficult to control because the primary material in a core melt is molten uranium dioxide at a temperature of several thousand degrees Celsius. In a chemical core catcher, a specially selected compound is placed under the reactor core. When the core debris reaches the floor, the decay heat melts the specific compound, and the uranium oxides are dissolved into the compound. The compound is chosen to have a high uranium loading and melt at a low temperature. The liquid with the dissolved uranium rapidly spreads out over the reactor building core in a geometry that allows rapid cooling. The major compounds that have been investigated for this application include B_2O_3 , $\text{Na}_2\text{B}_4\text{O}_7$, and lead borate ($\text{B}_2\text{O}_3 \cdot 2\text{PbO}$). The requirements for a chemical core catcher (high uranium solubility in liquid, fast dissolution, and low temperatures) are essentially identical to those needed for fusion melt isotopic blending.

The reactor core-catcher data suggest the potential for major process simplifications which would have a large impact on the cost of processing CEUSP and LWBR material. The CEUSP ^{233}U was solidified inside its stainless steel container and is partly attached to the container walls. Removal of the ^{233}U from the container would be a complex, expensive, mechanical operation. If the dissolution kinetics are sufficiently fast, a relatively simple batch process operation would be possible. The furnace with disposable inner liner would be loaded with the borate flux and some DU oxide. The ^{233}U container would be cut into several pieces and dumped into the liner, the furnace would be heated to operating temperature, and the ^{233}U would be dissolved into the molten mixture from the container pieces. After dissolution of the ^{233}U , additional DU would be added to the furnace, the dissolution process would be completed, the melt would be cooled, and the solid product (with container parts) would be packaged as one piece. This type of operation is inconsistent with production of high-quality glass but may be feasible if the product does not need to meet YM-type waste-glass performance specifications.

4.4.2 Uncertainties

Work is required to develop an uranium glass process. Many uranium glasses have been produced and recorded in the literature. However, these glasses have not been evaluated for their performance under repository conditions. Furthermore, only limited engineering data exists on these glasses. Because of the broad technical experience base with waste glasses, including HLW glasses containing several percent uranium, a technically acceptable glass can obviously be produced. However, the economics (processing, transport, and disposal cost) strongly depend upon obtaining a high uranium waste loading in the glass to minimize process equipment size and final glass volumes.

Work is required to develop a boron-oxide fusion melt process. The two borates of primary interest are B_2O_3 and $Na_2 B_4O_7$. The B_2O_3 should produce a product with a higher loading of uranium. Borax may have somewhat faster dissolution kinetics. Additional studies and thermodynamic and chemical kinetic data on uranium dissolution in fusion melts is required to predict (1) processing time and (2) if grinding of the feed is required in the process.

4.4.3 Conclusions

Both variants of the fusion melt option are workable and viable. Additional technical work is required to reliably predict costs. Based on available experimental data, the borate fusion melt technology is potentially the lowest cost technology to isotopically dilute ^{233}U with DU.

4.5 DRY GRINDING, BLENDING, AND SINTERING (STORAGE AND DISPOSAL)

In the dry-powder-blending process (Table 4.9; Fig. 4.8), ^{233}U oxide and DU oxide are ground to fine powders, mixed together, and consolidated to produce a ceramic-type material from which the ^{233}U cannot be separated from the ^{238}U by chemical or physical means. The final product could be sent to long-term storage, a WIPP-type facility, or a YM-type facility. To achieve these goals requires that the process must fuse the finely ground mixture of oxide particles and should promote the interdiffusion of DU and ^{233}U atoms, irreversibly intermixing them on an atomic scale to a point that only an enrichment plant could separate them again.

Table 4.9. Summary: Dry grinding, blending, and sintering

Application	Storage, disposal
Acceptable ^{233}U feeds	Clean, LWBR, CEUSP
Method to convert to non-weapons-usable ^{233}U	Isotopic dilution
Disposal site	All
Criticality control strategy	Isotopic dilution
Technical description	<p>Excess ^{233}U oxides are ground and mixed with DU dioxide until the average particulate size is $\sim 0.5\ \mu\text{m}$. The powder is pressed and then sintered by heating to a high temperature. The product is a monolithic solid. If the ^{233}U and DU oxides have the same chemical compositions, several particle consolidation processes can be used. If the ^{233}U and DU oxides have different chemical compositions, a high-temperature sintering process is needed that isotopically mixes the two isotopes by solid diffusion. Fine-powder grinding and powder mixing is required for reasonable sintering times and temperatures.</p>
Assessment	
Advantages	This may be a low-cost process.
Disadvantages	<p>The process would be more complex to use for CEUSP feeds because of the presence of cadmium that will probably volatilize in the sintering furnace.</p> <p>The process uses fuel-pellet fabrication technology. This is a moderately complex technology. However, the product requirements for the dry-blend option are much less than those required for fuel fabrication; thus, simplification of the process should be possible.</p> <p>The process produces very fine ^{233}U particulates ($\sim 0.5\ \mu\text{m}$) that are a significant inhalation hazard. Special safety procedures would be required compared to most other disposition options.</p>
Evaluation	This potential option to isotopically blend all ^{233}U with DU is a reasonable one.

Dry BlendParticle Consolidation

Fig.4.8. Simple dry-blend processing for ^{233}U long-term storage or disposal options.

4.5.1 Process Description

The dry-blend processes are similar to the fabrication methods for LWR fuel pellets. Several equipment variants are possible. Two variants are described herein. The first variant uses essentially the same equipment as is used for fuel fabrication. The second variant modifies the equipment to simplify the process.

The ^{233}U to be processed (ORNL July 19, 1995) is removed from the storage wells and transported in a shielded carrier to the processing hot cell. A bagless loading procedure is used for contamination control. The material is processed in limited-sized batches for criticality control. Inside the hot cell, the material is inventoried for accountability control. After inventory, the containers are opened, and the contents are removed. Many of the containers, such as the CEUSP monoliths, require equipment to cut them open and to drill or otherwise extract the contents. After any large chunks are removed from the containers, they are crushed into granules before the material is sent to a ball mill to be powdered. Other grinding and mixing technologies may be used. Any of the oxide forms in which the uranium is stored (UO_2 , U_3O_8 , etc.) can be used. Metallic uranium and nonoxide uranium are converted to oxide (U_3O_8) by heating in a furnace under an air atmosphere before blending. The nominal processing rate is 1.2 kg of fissile uranium per day, assuming an operation of 3 shifts per day and a 4-h cycle per batch. The batch size is chosen to be 200 g to ensure criticality control. However, the processing rate could be increased by installing parallel systems. Material in the feed other than uranium oxides, such as cadmium, gadolinium, or thorium oxide, will remain with the uranium oxide throughout the process and be present in the final product.

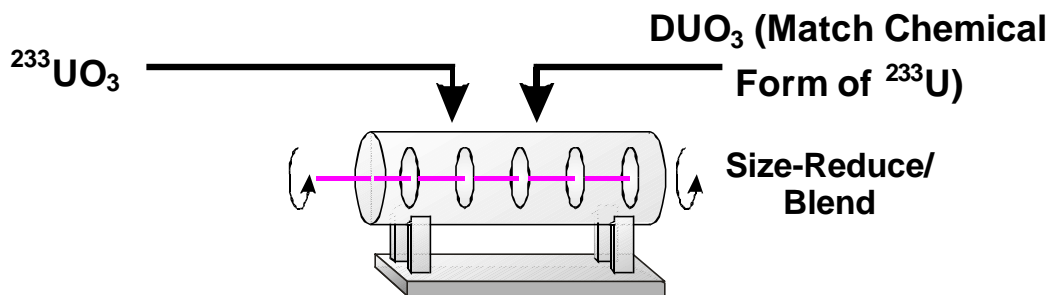
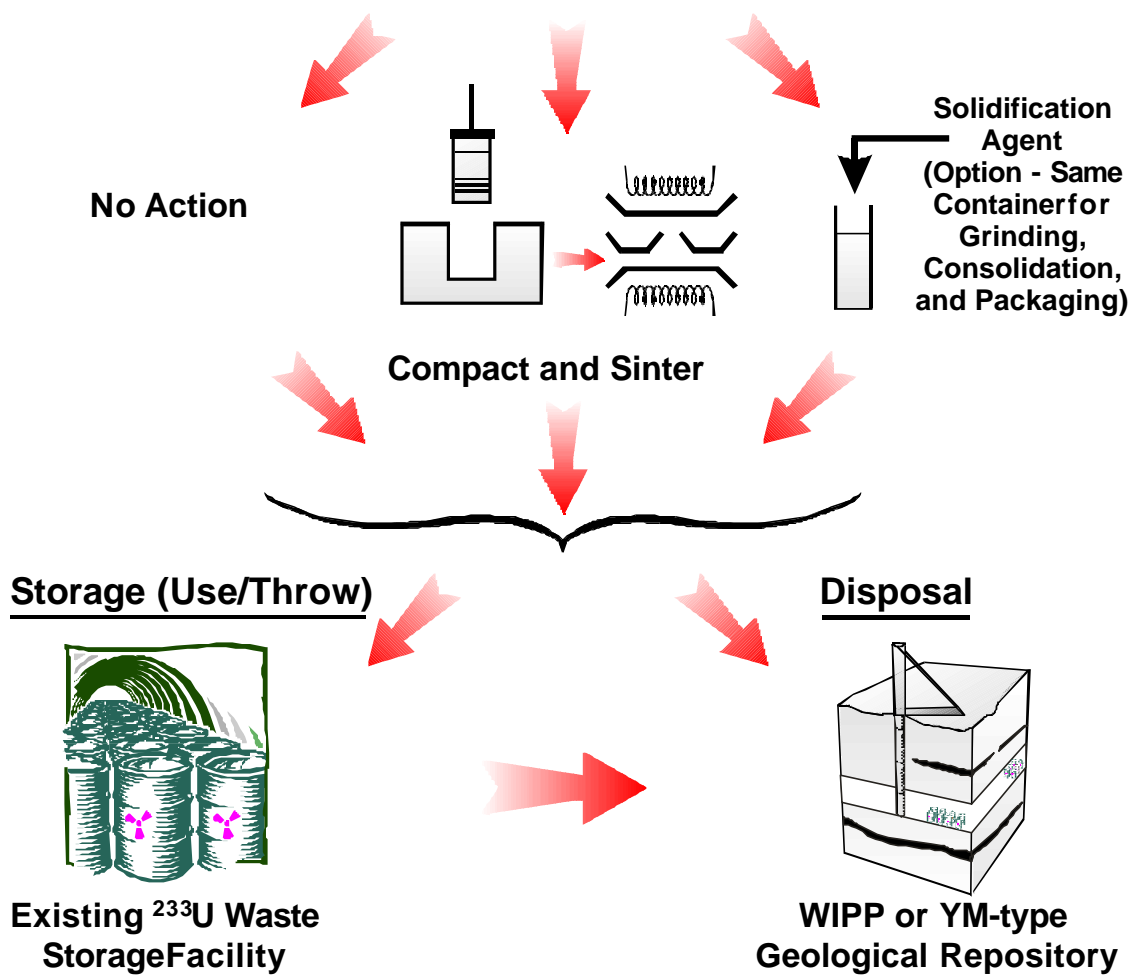
Blending begins by adding a weighed amount of ^{233}U oxide powder with a predetermined quantity of DU dioxide powder in a mixing vessel. DU dioxide for blending is prepared outside the hot cell. Mixing the powder is accomplished by rotating the mixing vessel in a tumbling apparatus for a prescribed length of time. An organic binder (to aid in the subsequent pellet-making process) is added and blended with the powder during the mixing operation.

Cold-pressing of the mixed oxide powder is accomplished by an automatic press. Blended powder is fed into a cavity and pressed by a piston. The ensuing pellets are to be limited to a mass of 57 g or less and a maximum diameter or height of 3 cm, and the nominal fissionable material in each pellet will not exceed 1 g. The pellets are then ejected from the cavity into a sintering tray. The pressing creates a sinterable product.

The uranium oxide pellets are placed in a sintering oven and heated to a temperature that is sufficient such as to vaporize the organic binder and to heat the pellets to near melting. The sintering process

converts different uranium oxides to uranium dioxide (UO_2). The pellets reduce in size as the volatile materials are driven off. The finished pellets will be ~90% of theoretical density (9.86 g/cm^3 for UO_2) of the mixed oxide. The sintering also increases the particulate size and reduces the inhalation hazard associated with small particulates. After the pellets are sintered, they are allowed to cool and are then transferred to an area for nondestructive analysis to verify their fissile content.

The dry-blend process does not introduce any additional material into the product other than the DU. Isotopic dilution of 1 kg of ^{233}U by the dry-blend process will produce 9.5 kg of non-weapons-usable UO_2 (8.407 kg U) product having a pellet volume of ~0.96 L. Blending 1 kg of ^{233}U with DU to eliminate long-term criticality will produce 214 kg of uranium oxide (189 kg U) product having a pellet volume of ~21.7 L. The density of the pellets can be partially controlled by the pellet's pressing and sintering conditions. However, the actual waste volume per kilogram ^{233}U will be higher because of the presence of other material (thorium, cadmium, and gadolinium oxides) in the ^{233}U material, any additional DU required to dilute ^{235}U contained in the ^{233}U material, and any DU added to accommodate measurement uncertainties.

After sintering, the pellets are placed in the inner containment vessel (can), which is sealed by welding. The can is then enclosed in an outer container to provide double containment for storage and shipping. Off-site transportation is carried out in shielded over-packs that meet U.S. Department of Transportation (DOT) requirements.

There are several other equipment configurations to the simple dry-blend option (R. Harmon, C. V. Smith, and R. Henry 1998). One option being examined for dry down-blending of HEU with DU consists of grinding and mixing $^{235}\text{UO}_3$ and DUO_3 in a dual drive planetary mill with alumina ball grinding media for ~75 minutes. This option has both advantages and disadvantages. The grinding media remains with the uranium oxides and occupies ~35 vol % of the final product. The use of a grinding media—rather than separate grinding and mixing steps—may allow the grinding and blending container to be used as a final product container provided that the container can be compressed and survive sintering furnace conditions. This avoids transfer of the fine powder during operations.

4.5.2 Variant Isotopic Mixing Methods with Dry Blending

There are three dry blend options. The options, their advantages, and their disadvantages are described herein. The option described previously was chosen as the baseline dry-blend option because of identified limitations in the other dry blend options.

4.5.2.1 Dry Blending Only

Currently, it is uncertain whether powder mixing of ^{233}U and DU in the same chemical form assures isotopic irreversible mixing. If the particle sizes are large, many types of commercial equipment exist to separate powders with different densities. There is almost a 2% difference in the densities of $^{233}\text{UO}_2$ and $^{238}\text{UO}_2$. At small particle sizes ($<1\ \mu\text{m}$), there is the potential of self-separation by alpha-initiated Brownian motion. During alpha decay, a high-energy alpha particle is emitted. With small particulates, the recoil from alpha decay can move the $^{233}\text{UO}_2$ particle. In a mixture of $^{233}\text{UO}_2$ and $^{238}\text{UO}_2$ particulates, the lighter $^{233}\text{UO}_2$ with its alpha-driven motion may preferentially work its way to the top of a powder mixture. This type of potential separation mechanism does not exist when mixing $^{235}\text{UO}_2$ and DUO_2 powders to create LEU because of the relatively low radioactivity of each uranium isotope.

For disposal in a YM-type repository, dry blending by itself does not produce an acceptable waste form. The current waste form requirements (DOE, August 30, 1994) prohibit waste forms containing fine particulates. Dry blended solids could be put into storage.

4.5.2.2 Dry Blending and Consolidation

To avoid self-separation mechanisms, powder mixtures can be consolidated into a matrix after blending. The powders can be sintered into pellets at relatively low temperatures or incorporated into a matrix such as cement. Consolidation also minimizes risks from respirable particles during storage, transport, and disposal. Some disposal sites (e.g., YM) prohibit fine particulate waste forms.

To assure irreversible isotopic mixing, identical chemical compositions for ^{233}U and DU are required to avoid the potential for separation of the two isotopes by selective chemical dissolution of one species or the other species with appropriate dissolution agents. Dry-blend processes that mix powders followed by consolidation would be difficult to use with CEUSP material and impractical to use with LWBR material.

- *CEUSP ^{233}U* . The CEUSP material contains gadolinium (a rare earth) and cadmium oxides. Gadolinium oxide in UO_2 is used as a burnable neutron absorber in nuclear fuels. Rare earths are major fission products in SNF. This type of system has been studied in detail. Oxidation and dissolution studies (Hanson July 1998; McEachern and Taylor 1998) have shown that the addition of rare-earth oxides—such as gadolinium oxide—to UO_2 significantly alters UO_2 oxidation and dissolution rates under a wide variety of conditions. It is expected that this phenomenon would also be true for other uranium oxide species. To blend CEUSP material would require that the DU oxides have the same concentrations of cadmium and gadolinium oxides as the CEUSP material and have the same physical and chemical forms (sintering temperatures etc.) to avoid separation by selective dissolution of one material or the other.

- *LWBR ²³³U*. The requirement that the ²³³U and DU have the same chemical form applies to the LWBR material. However, the LWBR feed contains only 1 to 12 wt % ²³³U in high-fired ThO₂ and must be matched to a comparable feed. The DU (for blending purposes) would contain 1–12 wt % DU in high-fired ThO₂. Because of the low concentrations of uranium in the thorium, large quantities of ThO₂ would be required to make the DU feed. The LWBR ²³³U contains ~350 kg of ²³³U incorporated in 14 t of ThO₂. To isotopically dilute the ²³³U to non-weapons-usable material would require DU in about 120 t of ThO₂. To eliminate criticality concerns, over 2,000 t of ThO₂ with DU would be required. This implies a large dry blending facility to handle the ThO₂ masses.

4.5.2.3 Dry Blending with High-Temperature Sintering

If the ²³³U feed has variable or complex chemical compositions (CEUSP and LWBR ²³³U), dry blending with high-temperature sintering does allow the use of normal DU oxides to isotopically dilute the ²³³U. With this dry-blending variant, solid diffusion during high-temperature sintering causes isotopic blending. Fine grains of DUO₂ and the ²³³UO₂ diffuse together into larger single crystals. There is applicable industrial experience. In the fabrication of LWBR fuel pellets, ThO₂ and ²³³UO₂ powders were blending, pressed into pellets, and sintered at high temperatures until the thorium and uranium interdiffuse to create a homogeneous Th-U oxide. This does require fine-powder blending (~0.5 μm). Long sintering times (hours), and high sintering temperatures (~1800 °C) assure diffusion of the DU oxides into LWBR or CEUSP feed materials.

There are two specific types of complications using this approach with the CEUSP ²³³U. At the required sintering temperatures, much (perhaps all) of the cadmium oxide may vaporize into the off-gas system (sublimation temperature of cadmium oxide is ~1500 °C) with unknown effects on the furnace components. Second, for a YM-type repository, RCRA (chemically hazardous) materials are not accepted. The cadmium must be (1) shown to be a beneficial material for criticality control and thus not regulated as a RCRA material, or (2) removed from the feed, or (3) shown that it does not leach into groundwater using the EPA TCLP waste leaching test.

4.5.3 Safety Issues with Dry-Blend Options

The dry-blend options may require some additional safety precautions. The primary hazard of ²³³U is the internal radiation dose upon inhalation. The risk from inhalation is primarily dependent upon the particulate size. Only small particulates (<1 μm) can easily be inhaled into the human lung. This process requires that the ²³³U oxides be reduced in size to ~0.5 μm—the size range of high-hazard particulates.

With the dry-blend process, there is also the danger of creating pyrophoric powders with certain feeds. Many materials, such as UO₂, are pyrophoric in fine powder form; thus, appropriate process safety measures must be implemented. If the UO₂ is sintered, the final product is inert and is not pyrophoric. If

the blended powder is to be sent to long-term storage (not disposal), it is required that the powder be converted to a nonpyrophoric form such as U_3O_8 (DOE December 1998). The storage standards for both ^{233}U and ^{235}U (Cox July 1995) do not allow storage of pyrophoric powders.

4.5.4 Mechanisms of Isotopic Dilution with High-Temperature Sintering and the Implications on Process Design

The applicable experience base for this option is fuel fabrication—particularly LWBR fuel fabrication. However, fuel fabrication is relatively complex because of the need to make nuclear fuel pellets which meet multiple requirements. For dry blending, simplified flowsheets may be viable because (1) the primary criteria is isotopic dilution and (2) most fuel fabrication requirements are irrelevant. Process simplification may be possible.

The grinding and dry-blending processes for the storage and disposition process are similar to the fabrication methods for LWR fuel pellets, (Frankhauser et al., 1967), (Leitnaker, Smith and Fitzpatrick, 1972). Since the final product tolerances for storage and disposition materials are not as severe, several equipment and processing variations are possible. Two processing scenarios are compared herein. The first scenario uses essentially the same equipment and process steps that are used for fuel fabrication. The second scenario modifies the equipment and eliminates steps to simplify the storage and disposition process and reduce its costs.

Both scenarios require that the ^{233}U oxide and DU oxides be ground to about an average diameter $0.5 \mu m$ with a surface area of $\sim 8.0\text{--}9.5 \text{ m}^2/\text{gm}$. In the case of fuel fabrication, the fine powder mixture is ground and blended in five to six steps or passes. Historically, this grinding of the oxides to such a small particle size was accomplished by using a sequence of two different sets of equipment (Belle et al., 1976). After being milled, the final “micronizing” is done in a pulverizer. In the case of the storage and disposition process, we would like to reduce the number of steps and the associated equipment and handling. Modern mills may be capable of achieving these particle sizes in one step.

The pressing of these powders into “green” pellets before sintering is essential to meet the goal of achieving high theoretical densities in the final product in order to ensure that the fuel pellets have good thermal conductivities. To achieve this in fuel fabrication, the powders are agglomerated to aid handling, treated with binding and mold release agents, and cold-pressed at around $\sim 35,000$ psi. This results in a pressed “green” pellet that can be handled and that has tightly controlled dimensions. However, this treatment also requires that there are necessary preheating treatment stages in the sintering process that removes the added binding and release agents. These process steps require sequentially heating the pressed

green pellets to ~350, ~600 and over 900°C under a CO₂ atmosphere in order to decompose the reagents, to react with the residual carbon, and to volatilize the remaining residues, respectively. In the case of the storage and disposition process, almost all of these steps should be by-passed.

However, there are some aspects of powder pressing that are relevant to the storage and disposition process. At these pressures, the contact points of the powder particles are stressed to the point that their crystalline structures undergo force dislocations, the particles are plastically deformed, and their surface contact areas are increased (Olander, 1976). This gives the subsequent sintering processes a head start, accelerating the growth of the particles into coarse grains and facilitating the interdiffusion of atoms across the particles' increased contact boundaries. For the storage and disposition product, these coarser gains correspond to lower leachabilities. Also, the greater initial particle-particle contact areas will accelerate the atomic mixing between the ²³³U oxide and DU oxides. Therefore, a modified version of the powder-pressing treatment may be included in the storage and disposition process.

After pressing, both the green fuel pellets and the green storage and disposition products are ready to be sintered. The questions are, For how long, and at what temperature? Grain growth aside, the attainment of homogeneous isotopic dilution of ²³³U oxide in DU oxides is the controlling issue. The atoms in the ²³³U oxide and DU oxide particles must have time to diffuse into one another. The self-diffusion phenomenon is depicted in Fig. 4.9.

To achieve a 10:1 dilution of ²³³U in DU oxide, the mean self-diffusion distance, $\langle r \rangle$, must exceed the radius of the ²³³U oxide particle by 2.61 times. Between 1450 and 1800°C, the energy of activation for uranium self-diffusion is 88 kcal/mol (Belle 1961). Using these data, Table 4.10 calculates and extrapolates the diffusion self-diffusion coefficients and $\langle r \rangle$ for urania particles between 0.5 and 10 μm.

As the temperatures increase, so do the diffusion coefficients, and the times for atoms to reach the $2.61 \cdot r$ are reduced. At the fuel fabrication conditions of 1,800°C and 0.5 μm, it takes about ~14 h for homogeneous isotopic mixing. With 5 μm particles at 1,800°C, it would take 1,436 h. If we raise the temperature to 2,200°C, the 5-μm particles would take ~45 h to achieve isotopic homogeneity at 10:1 dilution. This would probably require an induction furnace under a reducing atmosphere of argon with 5% hydrogen. Note also at temperatures above 1,750°C, the volatility of UO₂ may become a control issue.

Self-Diffusion Time to Achieve 10:1 Atomic Dilution

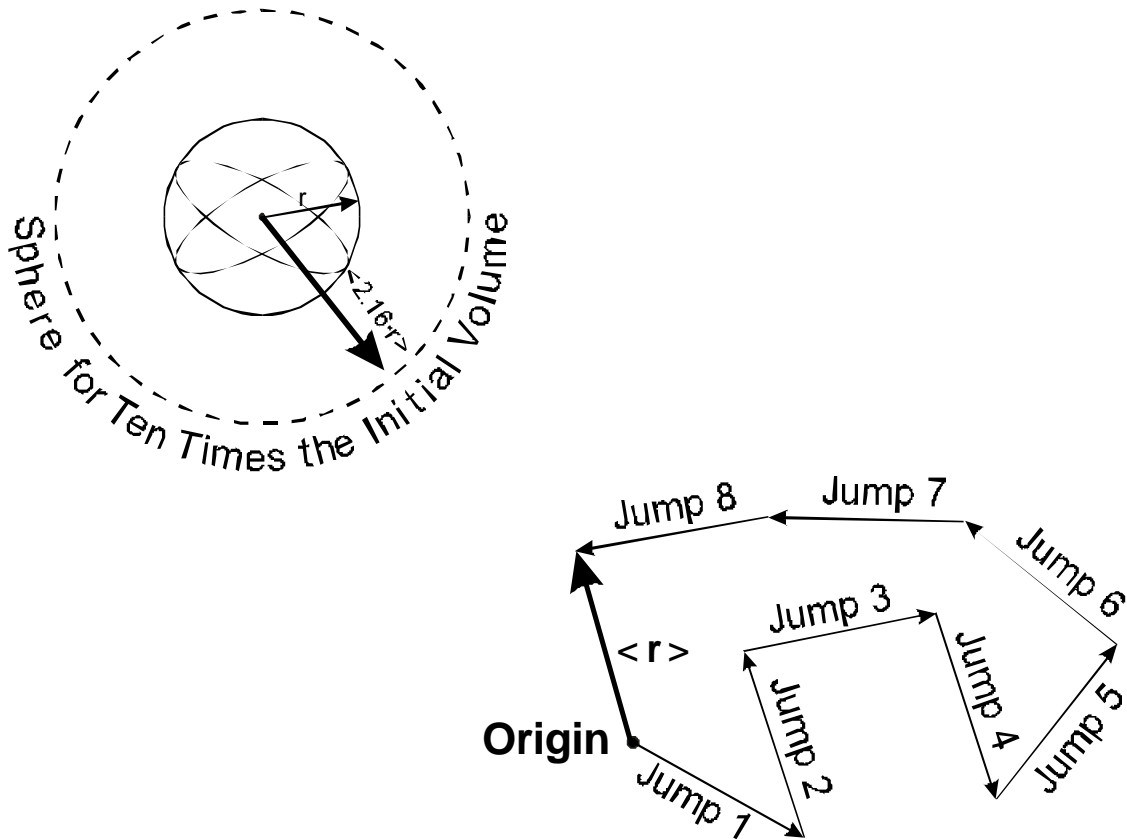

$$\langle r \rangle = \sqrt{D(T) \cdot t},$$

(where:)

$\langle r \rangle$ = average random displacement,

$D(T)$ = self-diffusion coefficient as a function of

T = temperature,

t = time.

Fig.4.9. Self-diffusion of uranium dioxide.

Table 4.10. The time required for the tenfold dilution of atoms, when the mean self-diffusion distances, $\langle r \rangle$, of the uranium atoms UO_2 are 2.16 times the original particles' radii

Temperature (°C)	Time (hours)							Uranium oxide self-diffusion coefficient, (cm^2/s)
	Original particle size (μm)							
	Radii	0.5	0.8	1	2	5	10	
1,400		2,375	6,080	9,500	38,000	237,500	950,001	1.364E-15
1,450		1,102	2,820	4,406	17,625	110,159	440,636	2.941E-15
1,500		534	1,366	2,134	8,537	53,357	213,428	6.072E-15
1,550		269	688	1,076	4,303	26,893	107,570	1.205E-14
1,600		141	360	562	2,249	14,059	56,236	2.305E-14
1,650		76	195	304	1,216	7,602	30,408	4.262E-14
1,700		42	109	170	679	4,241	16,963	7.640E-14
1,750		24	62	97	390	2,435	9,739	1.331E-13
1,800		14	37	57	230	1,436	5,744	2.256E-13
1,850		8.7	22.2	34.7	138.9	868	3,472	3.732E-13
1,900		5.4	13.8	21.5	85.9	537	2,149	6.032E-13
1,950		3.4	8.7	13.6	54.3	340	1,358	9.540E-13
2,000		2.2	5.6	8.8	35.1	219	876	1.479E-12
2,050		1.4	3.7	5.8	23.0	144	576	2.249E-12
2,100		1.0	2.5	3.9	15.4	96	386	3.362E-12
2,150		0.7	1.7	2.6	10.5	66	262	4.941E-12
2,200		0.5	1.2	1.8	7.2	45	181	7.150E-12

Note: The diffusion coefficients and times for temperature above 1800°C are extrapolated beyond the range of data used to establish the activation energy of uranium self-diffusion in UO_2 .

Considering only self-diffusion may be conservative because there are other transport mechanisms at work at the higher sintering temperatures. In the ~14-h sintering period used in fuel fabrication, the 0.5- μm particles merge and grow into grains >10 μm . There is a driving potential to reduce the high-energy surface areas of the fine particles that forces them to merge and grow into larger particles with a

much lower surface to volume ratios. Without external pressure, the mechanisms that facilitate this grain growth include (1) the more rapid diffusion of atoms on the surfaces of the particles and (2) the vaporization of UO_2 , followed by its condensation at the very narrow particle contact points. At temperatures above 1750°C , the kinetics of these mechanisms could be fast enough to preclude the necessity for cold-pressing the powder mixtures. Therefore, it may be possible to achieve the required isotopic homogeneity at reasonable temperatures, times, and particle sizes without having to press the mixtures before sintering.

The experience in fabrication of the LWBR fuel pellets is particularly relevant. The $^{233}\text{UO}_2$ and ThO_2 powders were ground to $\sim 0.5\ \mu\text{m}$. The pellets were pressed and sintered as $\sim 1790^\circ\text{C}$ for 12–14 h. The photomicrographs show large homogeneous UO_2 - ThO_2 grains. The homogeneous characteristics of these pellets suggest that the diffusion calculations are conservative and that one or more mechanisms described previously accelerate mixing on an atomic scale.

The previous considerations indicate that processes for dry blending of ^{233}U with DU for storage or disposal may be considerably simpler than those required for fuel fabrication with resultant implications for processing costs. As shown in Table 4.10, various combinations of particle sizes, temperatures, and sintering times can achieve isotopic dilution of ^{233}U . Because nuclear-grade fuel pellets are not required, it may be feasible to press at relatively low pressures uranium oxides into a disposable sintering-boat and avoid multiple handling operations. Other possible simplifications include the development of a “liquid” sintering reagent to be added to the ^{233}U oxide and DU oxide mixture to accelerate their mixing at lower temperatures. Ideally, this fluxing reagent would disappear, dissolving into the urania oxides.

4.5.5 Conclusions

The process is potentially viable for isotopic dilution of clean, LWBR, and potentially CEUSP ^{233}U and would produce a product acceptable for storage or disposal in any repository. Further process development may be required to (1) simplify the process when nuclear grade fuel pellets are not required and (2) address specific issues associated with cadmium in the CEUSP ^{233}U feed material.

4.6 CHEMICAL DILUTION: WASTE THRESHOLD (DISPOSAL)

If fissile materials are sufficiently dilute, they may be disposed of as other radioactive wastes. The option exists to dilute ^{233}U in other materials to low concentrations to eliminate it as a weapons usable material and then dispose of it as waste. This is summarized in Table 4.11 and Fig. 4.10.

Table 4.11. Summary: Chemical dilution: waste threshold

Application	Disposal
Acceptable ^{233}U feeds	All
Method to convert to non-weapons-usable ^{233}U	Chemical dilution of ^{233}U with fissile mass limits per container.
Disposal site	WIPP-type repository
Criticality control strategy	Mass limits (optional isotopic dilution)
Technical description	<p>There are two variants.</p> <p>Coprocess: The ^{233}U is mixed with TRUW for disposal at a WIPP-type facility with the ^{233}U being chemically diluted to <0.15 wt % ^{233}U.</p> <p>Stand-alone: The LWBR ^{233}U is packaged in special containers for direct disposal in WIPP (pipe-and-go variant). The ^{233}U mass is limited to <200 g/55-gal drum.</p>
Assessment	
Advantages	Low cost.
Disadvantages	<p>There are policy questions for the stand-alone variant: (1) does this option meet the Spent Fuel Standard and (2) does the United States want to advocate nonisotopic methods for conversion of weapons-usable ^{233}U to non-weapons-usable ^{233}U. The Spent Fuel Standard can be met with the coprocessing option if there is sufficient dilution of the ^{233}U with other wastes.</p> <p>There are institutional uncertainties associated with mixing CH TRUW and ^{233}U.</p>
Evaluation	<p>This is likely to be the lowest-cost disposition option for LWBR material—particularly if the operations can be integrated with ongoing CH TRUW processing operations at Idaho. It is potentially the lowest cost option for other ^{233}U.</p> <p>For the pipe-and-go variant, there is a policy question of whether this option fully meets the Spent Fuel Standard.</p>

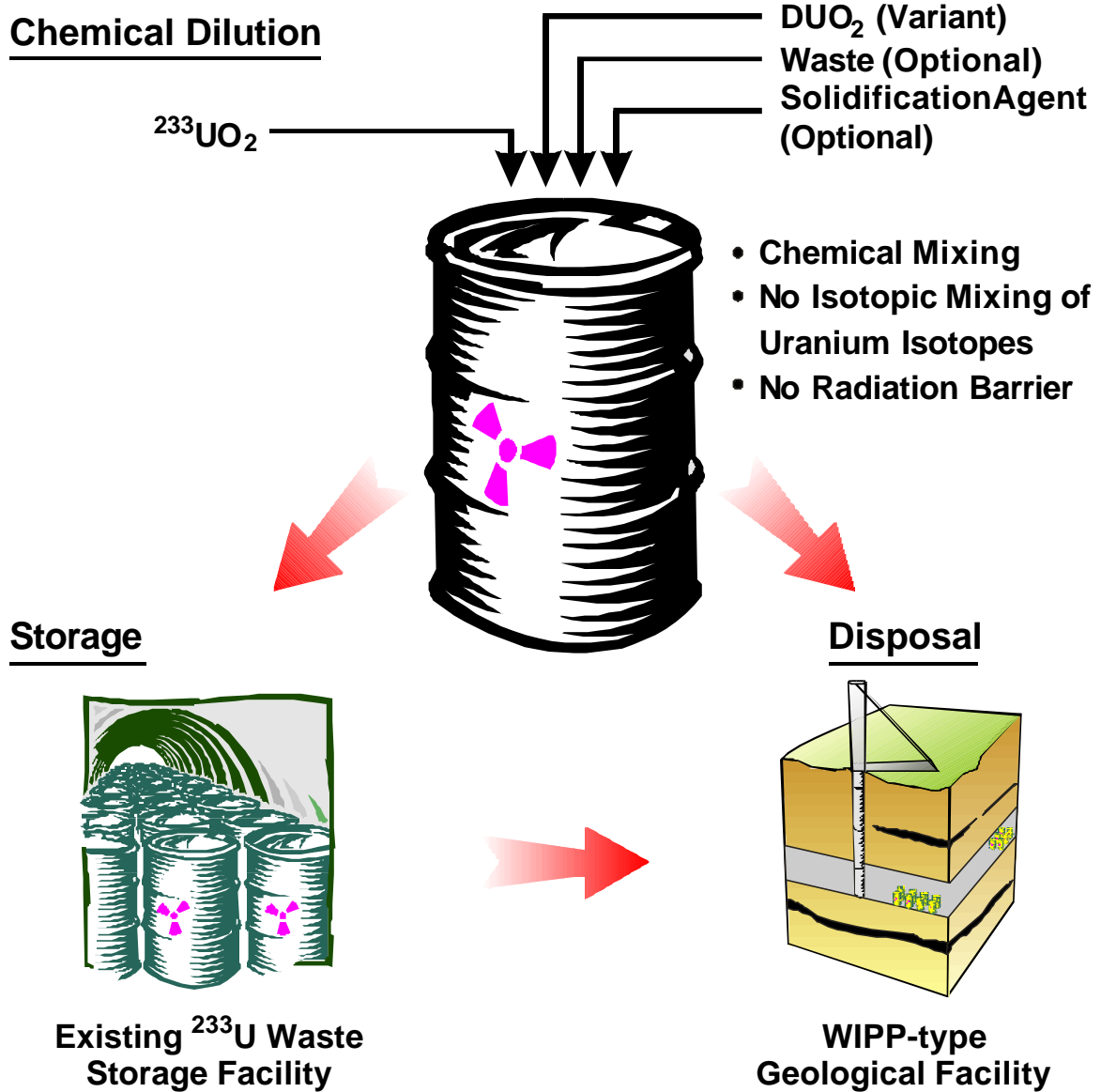

Fig.4.10. Chemical waste threshold disposition option for ^{233}U in a WIPP-type facility.

4.6.1 Definition of Waste Threshold

Radioactive wastes contaminated with low concentrations of fissile materials can be disposed of as any other similar radioactive waste. An example is HLW—which contains plutonium—that will be disposed of in YM. High-assay fissile materials can be an economic waste (no value or future use), but fissile materials can not be disposed of as traditional radioactive wastes because of the potential for (1) nuclear criticality and (2) use of such materials in nuclear weapons. Because fissile materials can be used for weapons, fissile materials have safeguards requirements that do not apply to typical radioactive wastes. The requirements for storage, transport, and disposal of traditional radioactive wastes—such as HLW—are significantly different than those for fissile materials. The definition of what is *waste* and what is *fissile materials* is defined as the waste threshold. This definition defines what material is to be disposed of as fissile materials. If the concentration of fissile materials can be reduced to a sufficiently low level by dilution with other materials to below the waste threshold, they can be treated as a normal radioactive waste.

Historically, a clear economic division has existed between wastes and some concentrated fissile materials. This division (the economic discard limit) was based on economic criteria for materials containing HEU or plutonium. These fissile materials are required to manufacture nuclear weapons and were in short supply during the cold war. Fissile material in any scrap and residue stream was considered waste only if the cost of the recovery of the fissile material exceeded the cost of producing new material. If clean fissile materials could be recovered from the scrap and residue stream for less than the cost of producing new material, the stream was considered concentrated fissile material. The high cold-war economic value of fissile materials resulted in low concentrations of fissile material in the wastes which, in turn, minimized concerns about nuclear criticality, safeguards, and arms control. With the end of the cold war, the United States had excess fissile materials, and the economic criteria dividing wastes from fissile materials are no longer applicable.

DOE has undertaken studies to define the new waste threshold. The ^{233}U waste threshold study (Forsberg, Storch, and Lewis July 7, 1998) concluded that there were three categories of materials:

- *Wastes* contain sufficiently small masses or low concentrations of fissile materials such that they can be managed as typical radioactive waste.
- *Concentrated fissile materials* contain sufficient fissile materials such as to warrant special handling to address nuclear criticality, safeguards, and arms control concerns. Certain concentrated fissile materials may have no use and are therefore excess material; however, they are classified and managed by their material characteristics rather than programmatic demand. Thus, even if a concentrated fissile material is not needed, it must not be managed as a waste until it meets waste criteria.

- *Exception case material* is defined as material that should be examined on a case-by-case basis to determine if it is waste. Many of the post-cold-war arms control and safeguards issues have not been fully resolved for plutonium and ^{235}U . Depending upon what is decided with the management of those materials, decisions can then be made about the specific ^{233}U -containing materials. It is likely that in many cases exception case material will be classified as waste requiring some additional special handling—between that required for wastes and that required for fissile materials.

Three issues impact the definition of wastes, exception case material, and fissile materials.

- *Domestic safeguards.* Concentrated fissile materials must be safeguarded to prevent their theft by domestic or international terrorists. Existing and proposed waste-management processing, storage, transport, and disposal facilities are not designed as high-security facilities to prevent theft of weapons-usable material. To be a waste, the fissile content must be sufficiently low (enrichment or concentration) such that it is not an attractive target for theft.
- *Arms control and international safeguards.* The United States has implemented a post-cold-war policy to encourage worldwide reductions in inventories of weapons-usable materials. The objectives include mutually verifiable reductions in weapons-usable fissile materials with Russia and, ultimately, other countries. As part of this policy, the United States has proposed that excess weapons-usable material in the United States and Russia be converted into a form that makes its recovery as difficult or more difficult than recovery of plutonium from LWR SNF. Logically, the criterion, known as the Spent Fuel Standard, should also be applied to all waste-containing materials; otherwise, any country could adopt waste management policies that declare concentrated fissile materials as waste and bypass the intent of the proposed arms-control treaties to limit weapons-usable fissile material inventories. Policy decisions are being made on the applicability of the Spent Fuel Standard to different types of waste. Not all issues have been resolved. Most fissile-containing wastes generated in the cold war meet the Spent Fuel Standard because they were considered wastes only if fissile material recovery was more difficult than producing new fissile materials. New fissile plutonium and ^{233}U were produced by recovering them from SNF or irradiated targets.
- *Nuclear criticality in disposal facilities.* Regulatory and performance requirements for disposal sites require that nuclear criticality be avoided (1) during the operational phase of the facility and (2) after disposal-site closure. Fissile materials may migrate in a disposal facility over geologic time frames. Waste form composition and special facility design features are required to avoid nuclear criticality. These requirements place limits on the concentrations and quantities of fissile materials in waste.

Based on analysis (Forsberg, Storch, and Lewis July 7, 1998) of the previous factors, the following definitions were proposed to define ^{233}U -containing wastes, ^{233}U exception case material, and ^{233}U -concentrated fissile material (Fig. 4.11). DOE has made no decisions on whether to adopt these recommended definitions.

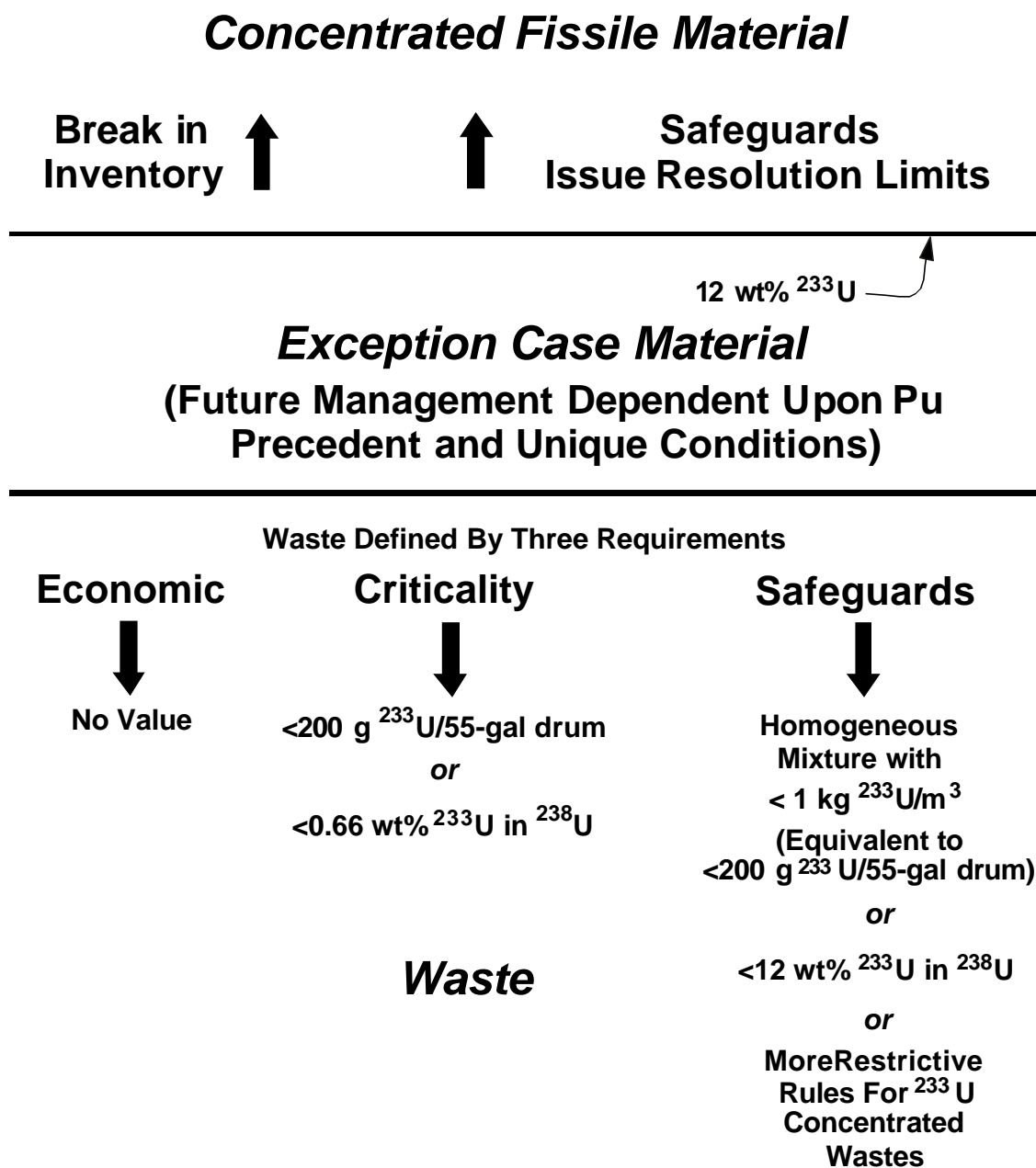

Fig.4.11. Definition of ^{233}U -containing materials.

- *Waste.* Uranium-233-containing material is waste if it meets three requirements: (1) there is no existing, planned, proposed, or potential use; (2) the ^{233}U (a) has a concentration of $<200\text{ g }^{233}\text{U}/55\text{-gal drum}$ or (b) the enrichment level is $<0.66\text{ wt } \% ^{233}\text{U in }^{238}\text{U}$; and (3) the ^{233}U (a) has an approximately homogeneous concentration of $<1\text{ kg }^{233}\text{U}/\text{m}^3$ (equivalent to $<200\text{ g}/55\text{-gal drum}$), or (b) the enrichment level is $<12\text{ wt } \% ^{233}\text{U in }^{238}\text{U}$. This definition includes the three requirements (economics, criticality control, and safeguards and arms control) that must be met to allow the material to be handled as other radioactive wastes.

Criticality control is assured (a) by limiting the ^{233}U concentration in the wastes ($<200\text{ g }^{233}\text{U}/55\text{-gal drum}$) to the same concentration limit as used by WIPP and other waste management facilities for operational safety (DOE April 1996) or (b) by isotopic dilution of ^{233}U with ^{238}U to a ^{233}U isotopic concentration limit ($<0.66\text{ wt } \% ^{233}\text{U in }^{238}\text{U}$) that is equivalent to $1\text{ wt } \% ^{235}\text{U in }^{238}\text{U}$ (Elam et al. 1997).

Avoidance of special safeguards and arms-control constraints is obtained by (a) limiting the ^{233}U concentration or (b) isotopically diluting the ^{233}U to $<12\text{ wt } \%$ with ^{238}U to make it non-weapons-usable material (Forsberg et al. February 1998). The requirement for an approximately homogeneous concentration of ^{233}U in the wastes explicitly recognizes that a small can of more concentrated ^{233}U in a large WP has fundamentally different safeguards and arms control implications than if the ^{233}U is distributed through the waste. If the ^{233}U is concentrated in the waste in a small fraction of the waste, it is easier to recover and this changes the S&S requirements. *Concentrated material* is defined herein as containing $>0.15\text{ wt } \% ^{233}\text{U}$ in non- ^{238}U materials. This concentration limit is identical to the maximum allowable plutonium content in wastes during the cold war (waste threshold). For containers containing concentrated material, the ^{233}U content of the container is limited to $250\text{ g}/\text{m}^3$ ($50\text{ g}/\text{drum}$) with certain other restrictions.

- *Exception case.* Exception-case material is defined as material that should be examined on a case-by-case basis to determine if it is waste. Many of the post-cold-war arms control and safeguards issues have only been partly resolved for plutonium and ^{235}U . Depending upon what is decided with the management of those materials, decisions can then be made about the specific ^{233}U -containing materials. For the purposes herein, *exception-case material* includes materials not in the definition of wastes as described above and containing up to $12\text{ wt } \% ^{233}\text{U}$ (chemical dilution in non- ^{238}U containing materials).

The upper limit of exception-case category is close to the maximum concentration of fissile materials proposed for any waste for which safeguards and arms-control restrictions may be reduced. It is also a natural break point in the ^{233}U inventory. There is little ^{233}U -containing materials between the highest assay ^{233}U fresh fuel ($12\text{ wt } \% ^{233}\text{UO}_2$ in ThO_2) and the inventories of nearly pure ^{233}U fissile oxides or mixtures of ^{233}U and ^{235}U .

- *Concentrated fissile material.* All other ^{233}U materials (excluding SNF) are defined as concentrated fissile material. These materials contain $>12\text{ wt } \%$ fissile material.

4.6.2 Disposal Options

The existence of a waste threshold allows disposal of ^{233}U as a waste if the concentration of ^{233}U is sufficiently low. There are two practical waste-threshold disposition options.

4.6.2.1 Convert to Waste: Process with CH TRUW

The ^{233}U can be chemically diluted with other materials until the product meets the classical definitions of waste. The diluent can be clean materials or other wastes with low fissile content. This option is applicable to all ^{233}U that is to be disposed of and is described in Table 4.11 and Fig. 4.12. The practical option is to mix the ^{233}U with TRUW (Fig. 4.12) and then disposed of in a WIPP type facility. This option is potentially attractive because of three factors:

- *Treatment process.* Construction is beginning (DOE January 1999) on the Advanced Mixed Waste Treatment Facility (AMWTF) at INEEL to convert existing CH TRUW into a form that meets WIPP WAC. The planned treatment process consists of several steps: (1) wastes are unloaded from the existing containers and sorted into categories; (2) combustibles are incinerated; (3) large components are cut into pieces and placed in drums or other containers; (4) incinerator ash, liquids, and small particulates are mixed with cement; and (5) the cement is placed into drums or other containers. Some of the drums and other containers will contain large components. In these cases, the cement is poured into the void spaces to make efficient use of drum volume. The solidified final product meets all WIPP WACs.

This flowsheet can be modified for ^{233}U disposition. Uranium ^{233}U is ground to a coarse powder and added with DU oxides to the cement containing the incinerator ash, liquids, and small particulates. The mixture is then poured into the waste drums. The ^{233}U grinding process would be similar to that described in Sect. 4.5 on dry blending except the particle size would be larger. This avoids the specific health and safety concerns associated with fine grinding of ^{233}U . Several other methods to create a feed are potentially possible.

- *Inventory location.* The LWBR ^{233}U and a large fraction of DOE TRUW are stored in Idaho. The AMWTF is being built in Idaho.
- *TRUW inventory.* The inventory of TRUW allows dilution of the ^{233}U to low concentrations without production of significant quantities of added waste. The projected final CH-TRUW processed-waste volume at INEEL is 36,530 m³, containing 720 kg of fissile material. This implies that the average CH-TRUW drum will contain <4 g of fissile materials/55-gal drum. In theory, about 35 t of fissile materials could be added to the existing CH-TRUW inventory at INEEL while meeting the WIPP WAC limit of <200 g fissile material/55-gal drum. The allowed 35 t of fissile material that can be added to this waste stream is more than an order of magnitude larger than the total quantity of ^{233}U in the inventory.

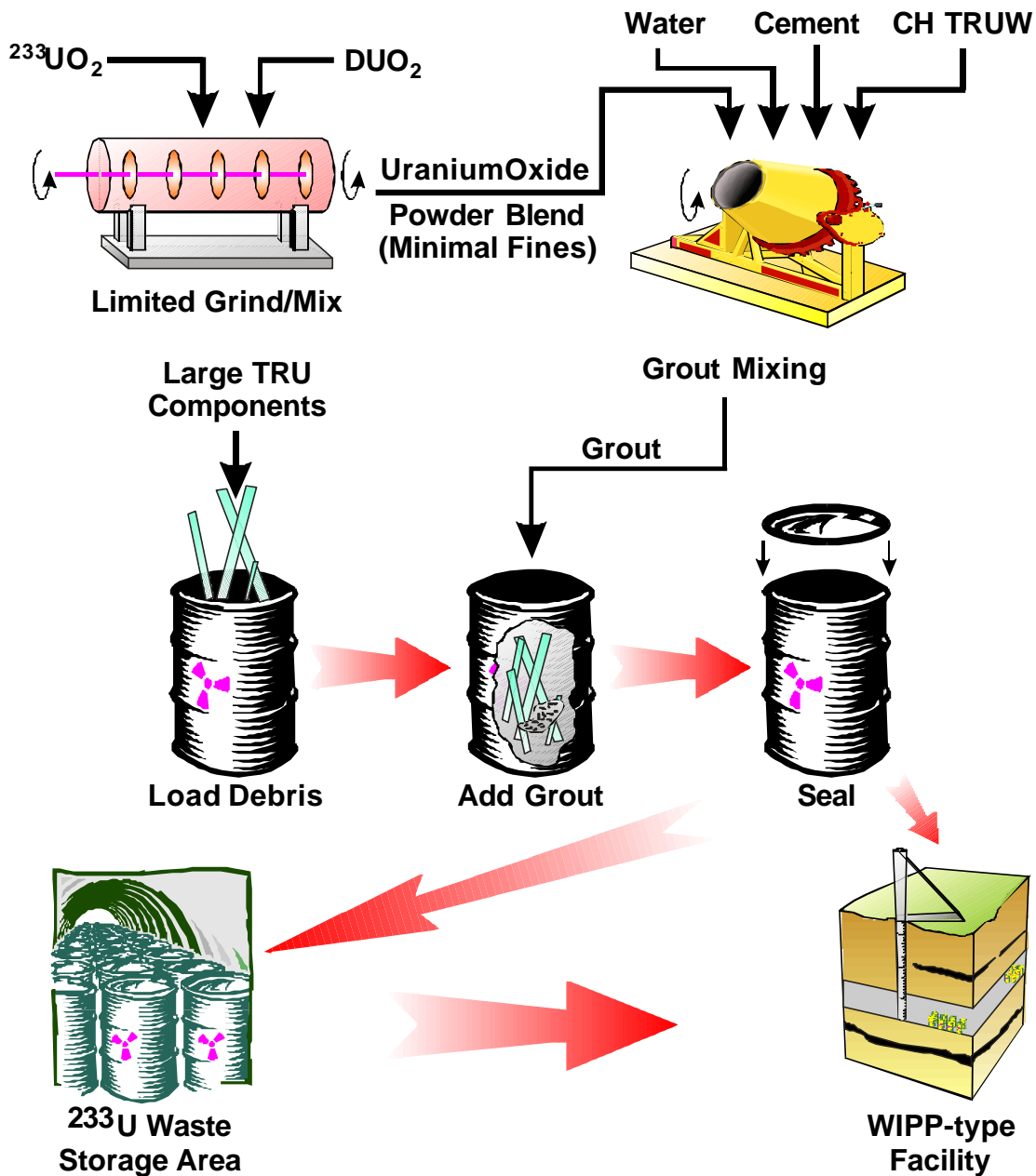

Fig.4.12. Chemical waste threshold ^{233}U disposition option: Coprocessing with CHTRUW.

Nationwide, the current and future quantities of TRUW available for mixing with ^{233}U are much larger. In theory, ~300 additional tons of fissile material could be added to the existing and future inventory of TRUW (317,600 m³) ultimately requiring disposal in a WIPP-type facility without violating WIPP-type criticality limits of 200 g/55-gal drum. For most of this waste, no decisions have been made on where it will be processed. A significant fraction is likely to be processed in the INEEL facility. The legal agreements with the State of Idaho allow processing of TRUW from other sites provided the processed TRUW is removed from the state within a fixed time after entering the state.

This variant is likely to be the lowest-cost option for the disposal of LWBR ^{233}U and a low-cost option for other ^{233}U . It uses facilities that are under construction. Preliminary evaluations indicate that this option does not significantly change those facilities and is unlikely to significantly impact the operating cost of those facilities. It does not significantly increase the number of drums going to WIPP-type facilities. The CH TRUW uses most of the physical volume of a waste drum. The ^{233}U uses excess fissile “capacity” of the waste drum, but very little of the volume of the drum because of the high densities of uranium oxides.

The option should allow disposition of ^{233}U with higher radiation limits. Processing of this material may require some modifications in process operations. To minimize radiation levels, two actions can be taken.

- *Dilution of ^{233}U .* The ^{233}U with higher radiation levels may require additional dilution with TRUW to control radiation levels (see Appendix A).
- *Special placement of cement containing ^{233}U .* The option exists to preferentially place the TRUW cement containing ^{233}U with higher radiation levels in the center of waste drums and place TRUW cement with lower radiation levels near the outside of the drum. In effect, low gamma-emitting wastes function as shielding for the higher gamma-emitting wastes.

It may be desirable to add DU with the ^{233}U . There are two benefits. It provides a higher assurance of criticality control and it makes recovery of the ^{233}U more difficult. Methods for recovery of uranium in low concentrations from cement would partially or fully isotopically mix the ^{233}U with the DU. These benefits are associated with clean and CEUSP ^{233}U but may not exist for LWBR ^{233}U . The unique chemical characteristics of the LWBR material would allow its separation from cement and DU. The barrier for LWBR ^{233}U recovery must be the large-scale dilution with TRUW.

There are institutional uncertainties. Can two materials be co-processed and sent to WIPP under the current regulatory and legal structures? The current legal and regulatory structure was not designed for this option and thus there are multiple ambiguities that must be addressed.

4.6.2.2 Convert To Exception Case Material: Stand-Alone Disposal

The LWBR ^{233}U may be disposed of as exception case material. DOE has recently developed a strategy for disposition of plutonium scrap and residue (Voorheis April 2, 1998; DOE August 28, 1998). This material is the plutonium equivalent of ^{233}U exception case material; thus, a similar strategy is potentially viable for ^{233}U . It has been decided (DOE February 11, 1999) to send most plutonium salts and other materials with plutonium concentrations of <10 wt % plutonium to WIPP for disposal. The amount of plutonium per 55-gal drum is to be limited to 200 g (criticality limit). Certain other restrictions have been proposed on the quantities of plutonium in shipment and storage to address S&S concerns. In effect, the disposition decision for these materials requires that an intermediate level of requirements (between those for wastes and those for pure fissile materials) be met for disposal of plutonium scrap and residue that have plutonium concentrations in a range between traditional radioactive wastes and concentrated fissile materials.

A parallel approach is potentially applicable to the LWBR ^{233}U inventory—with the final product sent to a ^{233}U waste storage area or a WIPP-type repository. This exception-case material has a ^{233}U concentration between fissile materials and ^{233}U wastes. It is not an option for other ^{233}U in the inventory. The clean and CEUSP ^{233}U would have to be diluted by a factor of 10 to meet the definition of exception-case material. However, DU is the logical dilution agent. If DU is used, the ^{233}U becomes non-weapons-usable material by isotopic dilution and the waste threshold option is moot. The option is described in Table 4.11 and shown in Fig. 4.11.

To implement this option, LWBR ^{233}U would be packaged in pipe containers with ≤ 200 g of ^{233}U per pipe container. One such container would be allowed per 55-gal drum. The waste may be managed the same way as CH TRUW. Each package contains <200 g of essentially pure $^{233}\text{UO}_2$ mixed with ThO_2 . Because of the small quantities of ^{233}U and the chemical dilution, the radiation levels from each package will be relatively low and the material may be handled in the same way as CH TRUW. This would be parallel to the proposed approach to manage many plutonium residues at Rocky Flats.

The LWBR material contains from 1 to 12 wt % $^{233}\text{UO}_2$ in ThO_2 vs <10 wt % plutonium in the pipe-and-go option at Rocky Flats. On a mass basis, 12 wt % $^{233}\text{UO}_2$ in ThO_2 is equal to 10.6 wt % ^{233}U heavy metal. This small fraction of the LWBR inventory is over the 10 wt % limit used to define what plutonium fissile materials may be disposed of via this option. However, the basis used to derive the 10 wt % plutonium limit would allow a higher concentration of ^{233}U in the form it is found in the LWBR inventory. The concentration limit for fissile materials using this option is imposed to minimize the risks of

unauthorized recovery of the fissile materials from wastes. The concentration limit is one of several mechanisms to accomplish this task. The other primary limit is that no drum may contain >200 g of fissile material. The 10 wt % plutonium limit was approved for plutonium in salts (McCallum May 15, 1998; Huizenga August 17, 1998) based on estimates of the difficulty of recovery of plutonium from this matrix. The ^{233}U in the LWBR material (with a maximum concentration of 10.6 wt % $^{233}\text{UO}_2$ in ThO_2) is much more difficult to recover than 10 wt % plutonium from salts. If 10 wt % plutonium in salt is acceptable, 10.6 wt % $^{233}\text{UO}_2$ in ThO_2 should be able to meet the same requirements.

This variant allows stand-alone disposition of the LWBR ^{233}U independent of the AMWTF. The expectation is that this is potentially the low-cost option for LWBR ^{233}U disposition but not as inexpensive as mixing with CH TRUW in the AMWTF. A preliminary estimated cost to transport and dispose of a drum of TRUW is ~\$8000/drum (Appendix D). With 350 kg of ^{233}U , the costs would be the packaging costs plus ~\$14 million for transport and disposal.

4.6.3 Special Issues with Waste Threshold Options

There are several issues associated with the waste threshold option.

- There are disagreements within the technical and policy communities on the acceptable concentrations of fissile materials in wastes (Bunn November 23, 1998; DOE November 1997). These disagreements are based on two considerations: (1) what is the acceptable risk of theft of wastes containing higher concentrations of fissile materials, and (2) what are the international implications to nonproliferation policies if the U.S. adopts a policy of allowing significant quantities of fissile materials in the waste?
- Does the United States want to establish a precedent of converting a weapons-usable uranium isotope to a nonweapons-usable material by any other method than isotopic dilution?

These issues directly impact any pipe-and-go option. They may or may not impact ^{233}U disposition by mixing with CH TRUW. With sufficient chemical dilution, the Spent Fuel Standard can clearly be met.

4.7 CAN-IN-CANISTER (DISPOSAL)

The can-in-canister option is being developed to dispose of excess plutonium. It is applicable for the disposition of excess ^{233}U . This option consists of (1) converting plutonium oxides (or ^{233}U oxides) into a ceramic form that is packaged into small cans, (2) placing the cans inside empty HLW canisters, (3) pouring HLW glass into the HLW canisters, and (4) embedding the cans in the HLW glass. The ceramic composition includes large quantities of neutron poisons to assure criticality control. The ceramic

is a highly stable waste form capable of withstanding the high temperatures within the HLW glass vitrification process. Some of the plutonium contains HEU. It is currently planned that sufficient DU be added to the ceramic so that any HEU fed into the process would be converted to LEU. The same strategy would be used for ^{233}U with the addition of sufficient DU to convert it to nonweapons-usable ^{233}U . The option is summarized in Table 4.12, the option is shown in Fig. 4.13 and a drawing of the canister with minicans is shown in Fig. 4.14.

The option is technically viable. Excess ^{233}U and plutonium could be processed and disposed of simultaneously or separately in the same facilities. The plutonium immobilization program has chosen a ceramic that contains significant amounts of uranium. The uranium in the ceramic can be ^{233}U , DU, or some combination. There are, however, constraints.

The proposed facilities for disposition of excess plutonium are being designed for CH glove-box-type operations—not remote operations. The plutonium feed acceptance criteria for the plutonium immobilization option allows <0.5 wt % ^{233}U in any feed material to the facility (DOE December 1998e) or <1 ppm ^{232}U in the ^{233}U feed material. This criteria is based on allowable radiation exposures to workers in the facility. As a direct consequence, only the LWBR ^{233}U could be processed by this option. The other ^{233}U materials could only be processed if the planned plutonium immobilization facility was converted from a glovebox operation to a hot cell operation. This would multiply the total facility costs by a factor of 2 or more and require additional years of equipment development. Consequently, it is not practical to process other ^{233}U feeds in the proposed plutonium immobilization facility.

If the LWBR ^{233}U was processed in the proposed plutonium immobilization facility, there are two options: (1) coprocess with the plutonium or (2) process in a separate campaign after plutonium processing.

- *Coprocessing.* The LWBR ^{233}U can be coprocessed with the plutonium. The baseline plutonium ceramic (Ebbinghaus February 1999) has a composition of about 10 wt % CaO, 10.7 wt % HfO₂, 23.7 wt % UO₂, 11.9 wt % PuO₂, 8.0 wt % Gd₂O₃, and 35.9 wt % TiO₂. The LWBR ^{233}U contains ~350 kg of ^{233}U in the form of UO₂ and 14 tons of ThO₂. In the proposed ceramic for plutonium immobilization, the ThO₂ can be used to replace some of the depleted UO₂ that is added to immobilize the plutonium. This has several advantages. First, <12 additional HLW canisters with immobilized ceramic cans would be required if thorium can replace DU on a 1 for 1 basis. Second, no separate waste form requiring separate testing and licensing for disposal is required.

Table 4.12. Summary: Can-in-canister

Application	Disposal
Acceptable ^{233}U feeds	LWBR
Method to convert to non-weapons-usable ^{233}U	Isotopic dilution, radiation barrier
Disposal site	YM-type repository
Criticality control strategy	Isotopic dilution, chemical neutron poisons
Technical description	Excess ^{233}U , DU, and other neutron poisons are converted into a high-performance ceramic that is packaged in small cans. The cans are placed inside empty HLW canisters and molten HLW glass is poured over the cans—incorporating the cans in HLW glass. This is the same technology that is proposed for immobilization of plutonium. The option exists to coprocess the plutonium and ^{233}U
Assessment	
Advantages	Technically viable option using the technology being developed for immobilization of excess plutonium. If the ^{233}U is coprocessed with the plutonium, there are significant cost and institutional advantages.
Disadvantages	Because of the radiation associated with the ^{233}U , only the LWBR ^{233}U could be coprocessed with plutonium. Stand-alone options capable of processing all ^{233}U (including ^{233}U with high ^{232}U levels) require modification of the DWPF (HLW glass plant) to handle radiation levels from “empty” HLW canisters with ^{233}U cans.
Evaluation	The option is potentially viable for the LWBR ^{233}U if the timing issues between the ^{233}U and plutonium program can be resolved.

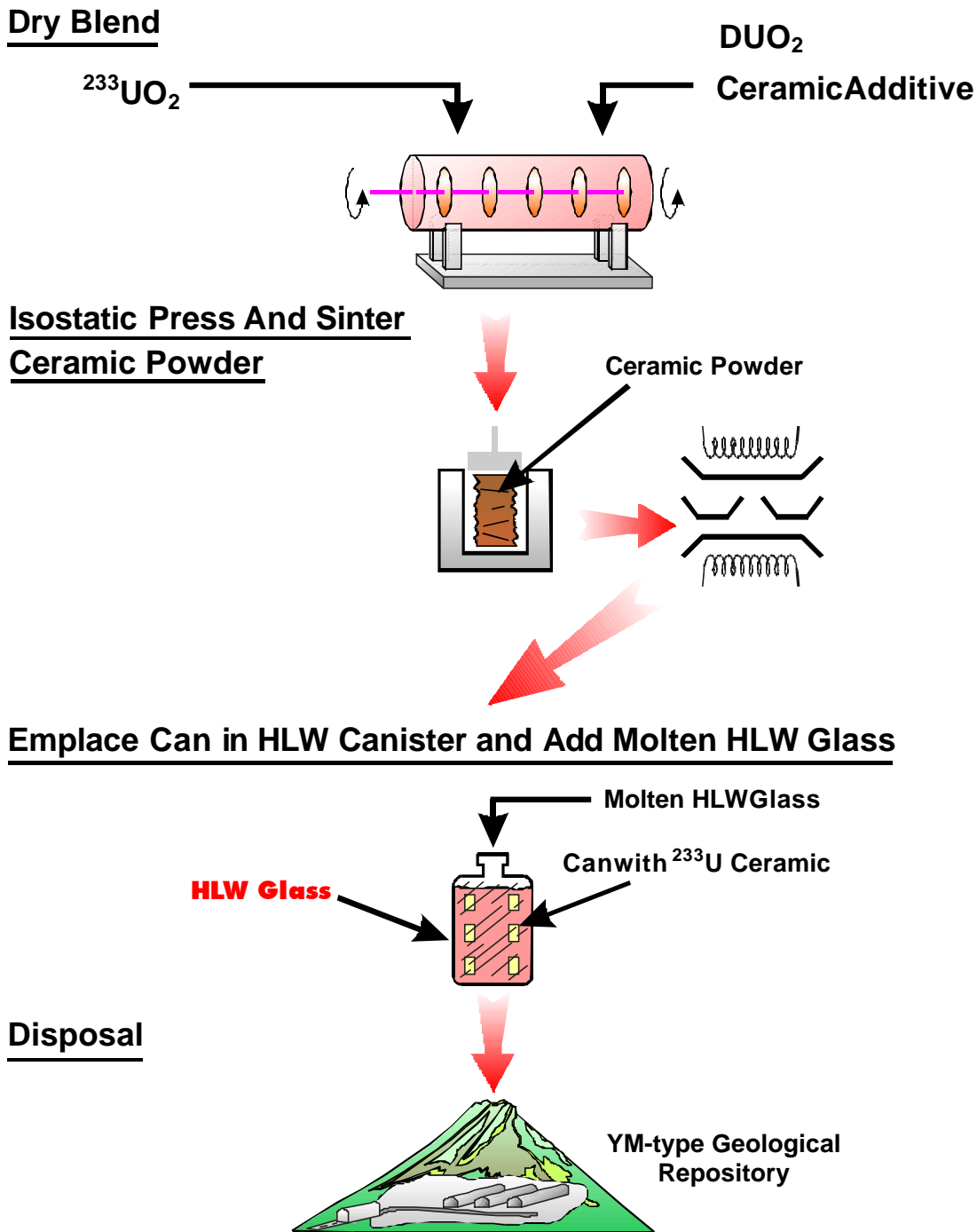

Fig.4.13.Can-in-canister ^{233}U disposition option.

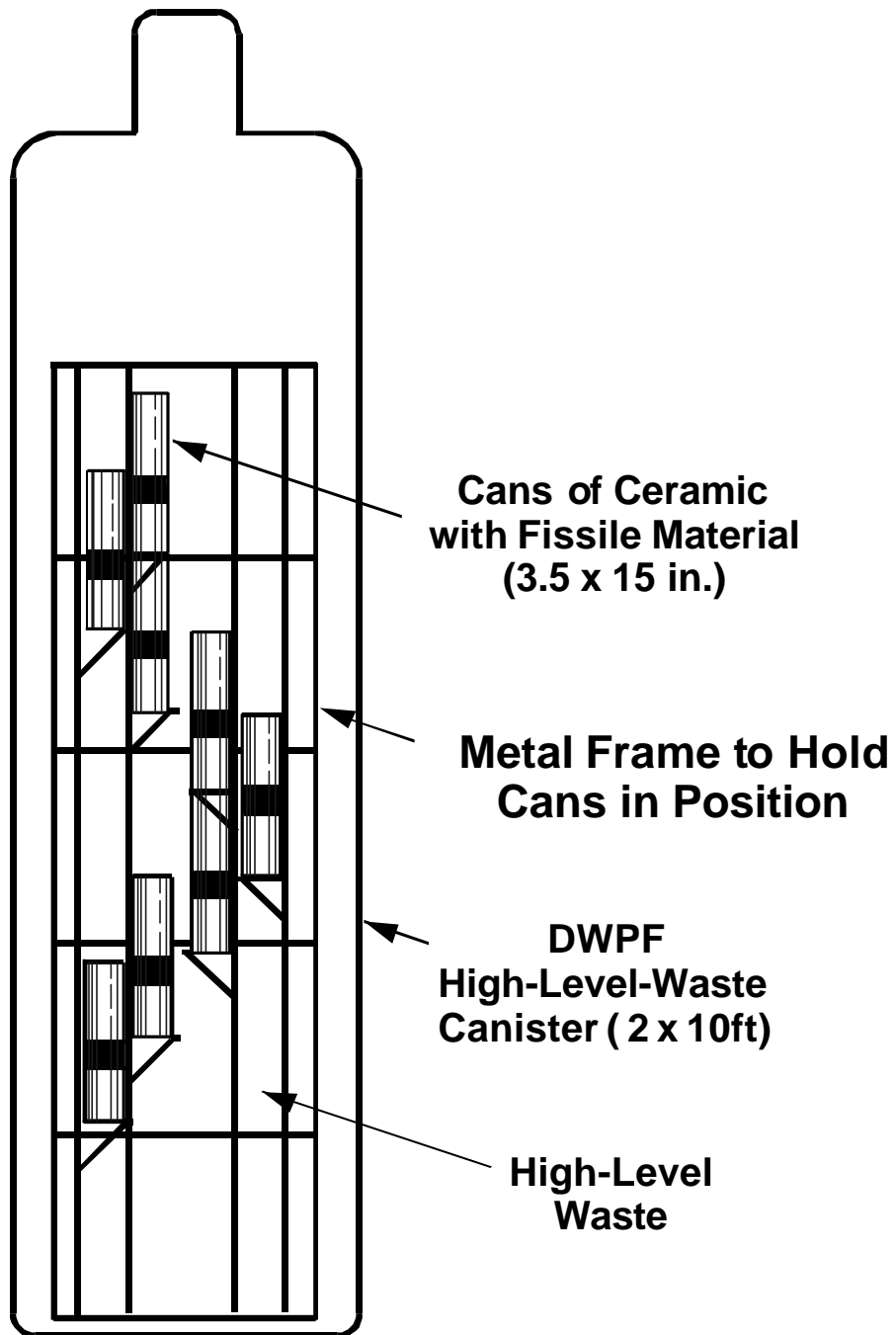

Fig. 4.14. Can-in-canister for disposition of ^{233}U or plutonium.

From the perspective of the plutonium immobilization program, there are advantages and disadvantages. The thorium would be expected to (1) increase the difficulty of recovery of the plutonium from the ceramic and (2) improve waste form performance because ThO₂ is significantly more inert than UO₂. The replacement of the depleted UO₂ would reduce the available DU for long-term criticality control in the repository.

- *Separate processing.* With separate processing in the proposed plutonium immobilization facility, processing times would be significantly increased because the 14 tons of ThO₂ in the LWBR ²³³U is an added feed to be processed, not replacements for depleted UO₂. With separate processing, a custom ceramic would need to be developed and qualified for this material. The quantity of waste to the repository would increase by at least one order of magnitude.

There is the option to create a stand-alone can-in-canister facility for ²³³U. The stand-alone option would be a remote-operated facility which would allow processing of any ²³³U with any level of ²³²U and any level of radiation. Such a facility would be similar to the previously described aqueous (Sect. 4.3) or dry-blend (Sect.4.5) options. The uranium would be isotopically diluted with DU and converted to an inert ceramic. Potential waste forms include UO₂ or a mixture of UO₂ and ThO₂. The addition of ThO₂ would increase processing temperatures but produce a better waste form. The product would be put into minicans that would then be placed into empty HLW canisters. HLW glass would be poured around the minicans. The primary advantage of this option would be to create an HLW (can-in-canister) glass form similar to that already accepted by the repository (Paperiello January 25, 1999).

There are complications with a stand-alone can-in-canister option in addition to the need for a separate RH processing facility. Significant modifications may be required to the DWPF—the HLW vitrification plant at SRS. The DWPF was designed on the assumption that the “empty” HLW canisters had low radiation levels and could be manually prepared and fed into the plant. HLW canisters containing plutonium ceramic cans but no HLW glass have low radiation levels and match this facilities design basis. None of the areas on the cold-side of the plant that handle empty HLW canisters have appropriate radiation shielding for canisters with ²³³U containing significant quantities of ²³²U and associated high-gamma radiation fields. These areas of the plant would have to be modified to allow transfer of canisters containing cans of ²³³U into the existing high-radiation areas in the facility.

The previous considerations indicate that the can-in-canister option is a potentially viable for the LWBR ²³³U; but, there are major difficulties in processing other ²³³U in the inventory.

4.8 RH TRUW PROCESSING (DISPOSAL)

Uranium-233 could be co-processed with DU and RH TRUW to produce a waste form acceptable for existing ²³³U waste storage facilities or a WIPP-type disposal facility. If the appropriate processing technology is chosen, the ²³³U would be isotopically diluted with DU. Because the handling requirements

for RH TRUW are similar to those required to handle ^{233}U , RH TRUW processing facilities would be expected to be able to process ^{233}U with minimal modifications. The ^{233}U has many of the characteristics of RH TRUW, and, historically, DOE has treated wastes with significant quantities of ^{233}U as TRUW and much of this waste as RH TRU waste. A summary of the option is shown in Table 4.13.

Currently, no RH TRU waste processing facilities exist; however, DOE plans to build such facilities to process and package RH TRU into forms acceptable for WIPP. Most of the inventory of RH TRU waste (DOE December 1996) generated in the United States is at two sites, ORNL and Hanford. Most of the future RH TRU waste will also be generated at these sites. Future facilities must ultimately be built at these sites. The final waste volumes would depend upon the specific processes that were chosen for processing and packaging RH TRU wastes.

4.8.1 ORNL

ORNL is considering several options for newly generated RH TRUW, including a small vitrification system for liquid wastes. Much of the newly generated RH TRUW at ORNL is liquid waste. If a small vitrification facility is built, the ^{233}U could be added to this waste stream with DU and co-processed with future RH TRU wastes (Fig. 4.15).

One specific variant of this option deserves special note: uranium can form part of the glass structure. This creates the possibility of using the uranium (DU and ^{233}U) as a glass former to incorporate other wastes into the glass. If this can be accomplished, the volume of the waste taken up by the ^{233}U would be reduced. The uranium would make up part of the waste form, not just the waste. However, the small, annual RH TRU waste generation rate would lead to a protracted ^{233}U disposal scenario. There are two uncertainties associated with this variant. The first uncertainty is the allowable loading of uranium in glass. Low waste loadings imply high waste volumes and correspondingly high transport and disposal costs. The second uncertainty is whether any facilities will be built that are compatible with disposition of ^{233}U . No decision date for treatment of these wastes has been announced.

4.8.2 Hanford

DOE's Hanford site in Washington state has a large inventory of solid RH TRUWs (no liquids). As part of the Triparty Agreement between DOE, EPA, and the State of Washington, a study will be initiated on methods to process this waste into a form acceptable for shipment to WIPP. The study has not yet been initiated. It is to be completed by June 1999 as Milestone 99 of the Triparty Agreement. The viability of using this facility for processing ^{233}U depends upon both a decision to build the facility and the technology chosen. If a technology such as plasma-torch processing is chosen for volume reduction, it would be applicable to ^{233}U disposition. If the facility is only a repackaging facility, it would not be suitable for a ^{233}U disposition mission.

Table 4.13. Summary: Co-processing ^{233}U with RH TRUW forms

Application	Disposal
Acceptable ^{233}U feeds	All
Method to convert to non-weapons-usable ^{233}U	Isotopic dilution
Disposal site	WIPP-type repository
Criticality control strategy	Isotopic dilution
Technical description	U-233 is coprocessed with proposed RH TRUW processing facilities. Process depends upon the specific facility.
Assessment	
Advantages	Low cost
Disadvantages	The option depends upon future construction of RH TRUW processing facilities at either ORNL or Hanford. No decisions have been made as to whether such facilities should be built.
Evaluation	The option exists only if RH TRUW processing facilities are built and the technology for such facilities is suitable for ^{233}U isotopic dilution with DU. No decisions are expected in the near-term.

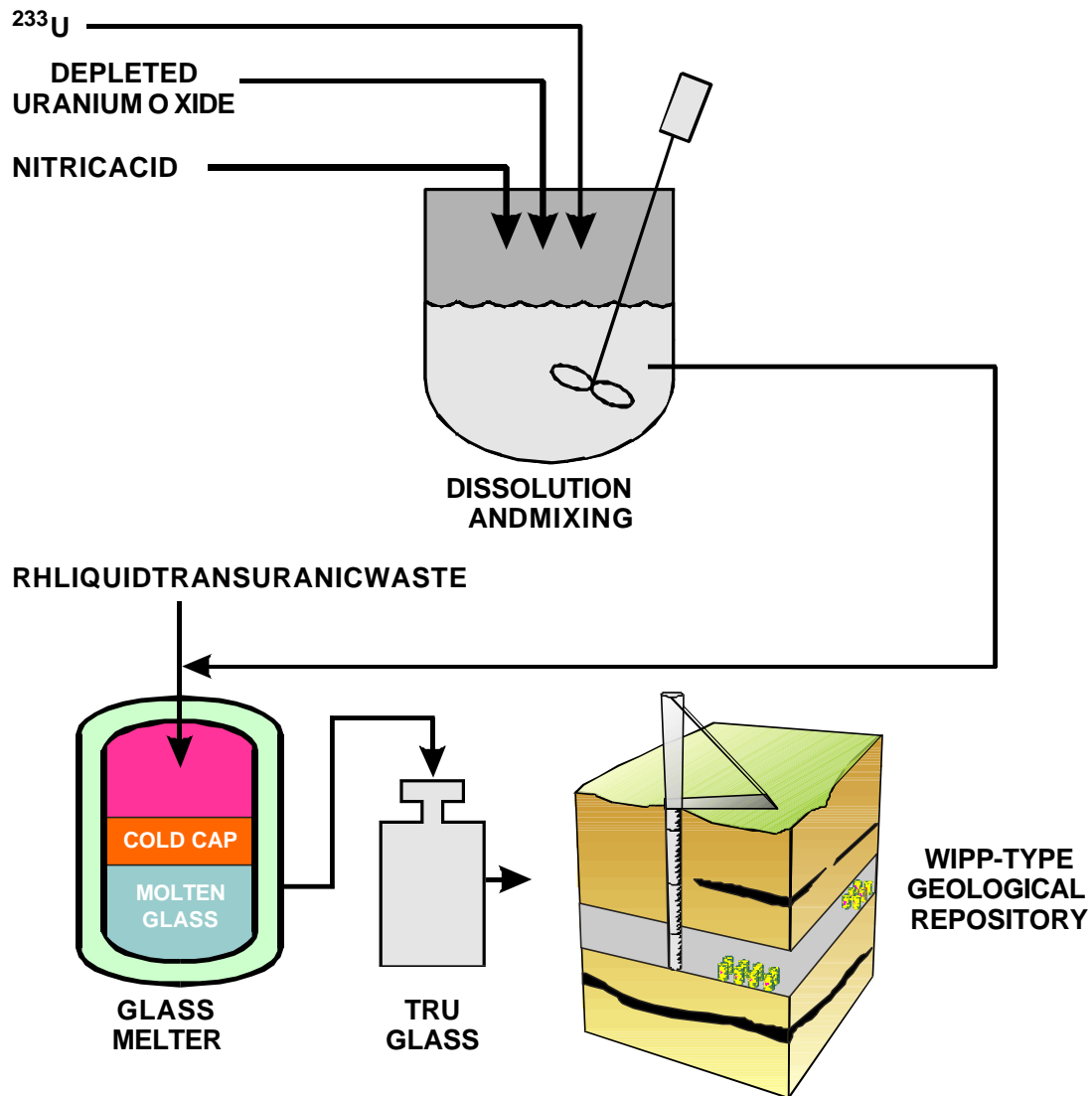

Fig.4.15. Co-processing of liquid RH TRUW and ^{233}U for disposition in a WIPP-type repository.

4.9 CH TRUW PROCESSING (DISPOSAL)

The United States is considering the building of one or more CH TRUW processing facilities to (1) convert untreated CH TRUW into treated CH TRUW suitable for disposal at WIPP and (2) reduce the volume and cost of waste transport and disposal. Some of the potential treatment technologies would allow simultaneous feeding of ^{233}U , DU, and CH TRUW to the process with isotopic mixing of the ^{233}U and DU within the process. Not all treatment processes are capable of achieving this objective. As a consequence, the viability of this option depends upon (1) a decision by DOE to build a CH TRUW treatment facility and (2) selection of a technology that assures isotopic mixing of ^{233}U and DU. Table 4.14 summarizes this option.

A CH TRUW treatment facility is being built at INEEL; however, the processes chosen for that facility are not capable of isotopically mixing ^{233}U with DU (see Sect. 4.6, "Waste Threshold Options"). Decisions have yet to be made at a number of sites on whether to build CH TRUW treatment facilities.

An example of a CH TRUW treatment process that would be usable for disposition of ^{233}U is the plasma torch process (Fig. 4.16). Pilot-plant experiments (S. D. Poling et al. March 9, 1994; R. L. Gillins and S. D. Poling, May 10, 1994; G. R. Hassel, R. M. Geimer, J. A. Batdorf, and G. L. Leatherman, May 10, 1994) have been conducted on this technology for CH TRUW treatment. In this process, the wastes are heated by a plasma torch to sufficiently high temperatures that organics are pyrolyzed and other wastes are converted to a glassy slag. A plasma torch heats the wastes. After the organics have been oxidized or pyrolyzed and a slag has formed, the slag flows through a hole at the bottom of the hearth into a waste container.

Isotopic dilution is assured by codissolution of the ^{233}U and DU into the slag. The slag provides a good matrix to contain the ^{233}U . The dense slag also provides significant radiation shielding against ^{232}U decay product gamma radiation. There are several unresolved issues for this and other candidate process options:

- *WIPP acceptance.* The plasma torch process can accept CH TRUW, but not high concentrations of uranium. Too much uranium would raise the melting point of the slag until the molten slag could not flow into the WP. There are similar technical constraints with most other CH TRUW treatment options. This implies that such options would require spreading the ^{233}U over a large number of WPs that also contain TRUW. Because of the large number of packages, it would not be desirable to add this material to existing ^{233}U waste storage areas. It should be directly shipped to WIPP. WIPP is authorized to accept TRUW and TRUW containing ^{233}U , but not ^{233}U wastes. In this case, the processing option mixes two previously separate streams. The regulatory status of such processed wastes must be clarified.

Table 4.14. Summary: Convert ^{233}U to CH TRUW form^a

Application	Disposal
Acceptable ^{233}U feeds	LWBR, All?
Method to convert to non-weapons-usable ^{233}U	Isotopic dilution, chemical dilution
Disposal site	WIPP-type repository
Criticality control strategy	Isotopic dilution
Technical description	Excess ^{233}U , DU, and CH TRUW are coprocessed into a processed CH final waste form.
Assessment	
Advantages	Potentially a low-cost option
Disadvantages	The option may increase radiation levels associated with CH TRUW. Radiation exposures probably limit option to LWBR ^{233}U unless other ^{233}U is processed with large volumes of CH TRUW.
	The option co-mixes ^{233}U and existing CH TRUW. There are uncertainties in whether such material can be accepted by WIPP.
Evaluation	The option exists only if CH TRUW processing facilities are built and the technology for such facilities is suitable for ^{233}U isotopic dilution with DU.
	No decisions are expected in the near-term.

^aThis option, when applied to LWBR ^{233}U , can be considered a variant of the waste threshold option.

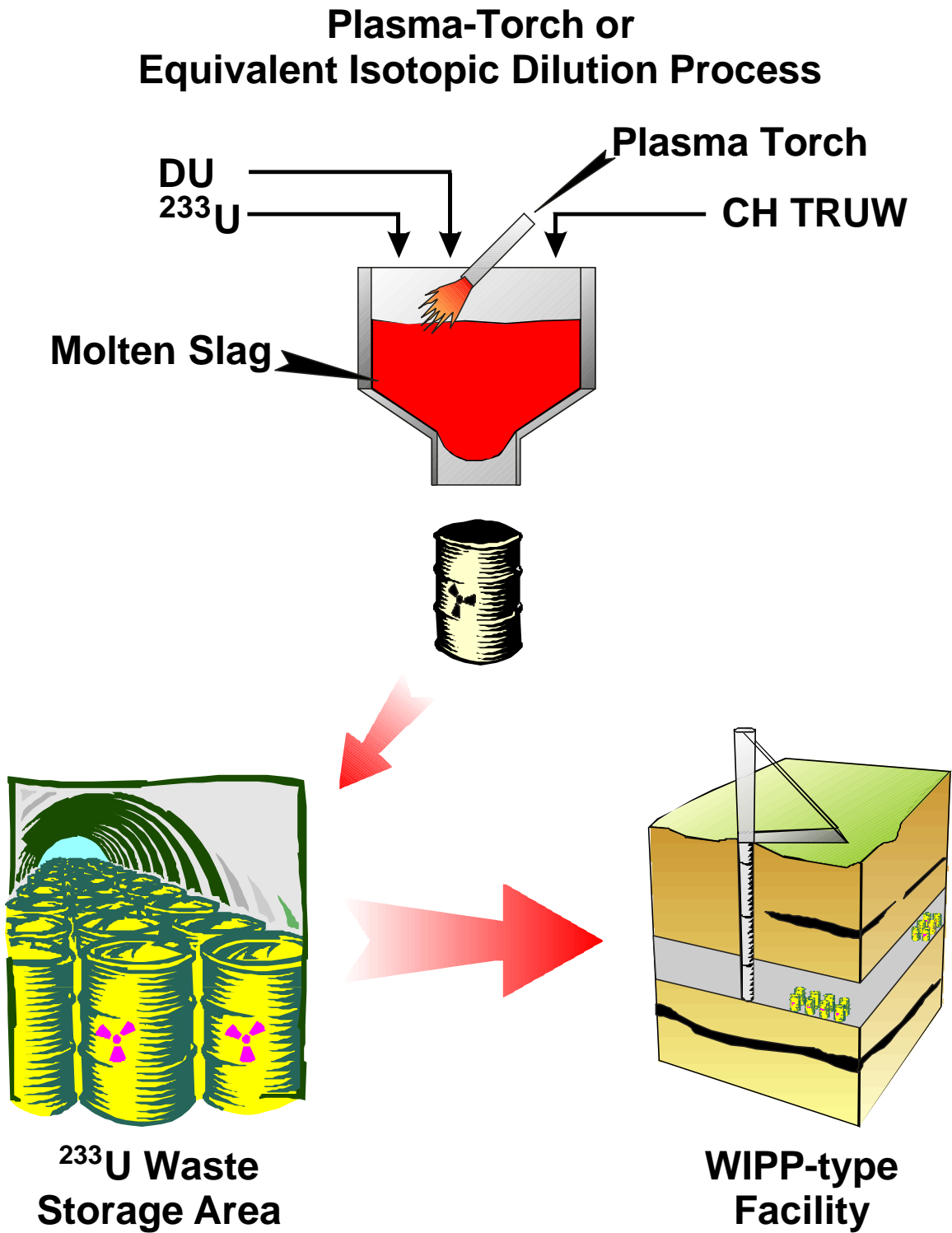

Fig.4.16. Uranium-233 disposition by co-processing with CHTRUW.

- *Radiation exposure.* Radiation levels are limited by dilution and self shielding. However, this option may increase total occupational exposure. The potential problems with radiation exposure are strongly dependent upon the ^{233}U feed material. The LWBR ^{233}U has the lowest radiation levels, and, thus, would be the most acceptable feed.

4.10 LWR FRESH FUEL (DISPOSAL)

4.10.1 General Description

One option for the disposition of ^{233}U is to use it in the fabrication of LWR fuel and its subsequent irradiation in a commercial nuclear reactor. To effect this option, the surplus ^{233}U would be blended with either DU or enriched, commercial-grade uranium to produce suitable fuel material. Table 4.15 summarizes the option.

The blending of ^{233}U -containing materials with DU (or enriched, commercial-grade uranium) is unique because of the unusual isotopes involved (most notably, ^{232}U and ^{233}U). The relatively small quantities of ^{233}U (as compared to the U.S. HEU inventory) would result in an expensive, special campaign. However, some of the ^{233}U materials are similar to HEU (i.e., they contain primarily ^{235}U). As a result, it is reasonable to consider the inclusion of these materials in a special campaign that is being planned for some HEU materials.

One specific option examined in this section is the blending of the surplus ^{233}U with DU and the surplus, off-specification HEU in storage at SRS, INEEL, and Y-12. This off-specification HEU has a high isotopic content of ^{234}U and ^{236}U (McWhorter 1995). Once irradiated, fuel containing the surplus ^{233}U would be destined for permanent disposal in the SNF repository.

The down-blending of HEU with DU results in a material with characteristics different from those of LEU produced directly through the enrichment process. Most notably, this down-blended material will have a higher isotopic content of ^{234}U than that of the LEU produced directly from enrichment. Additionally, the surplus, off-specification HEU has a high ^{236}U content which will in turn results in a high ^{236}U content in the LEU that is produced from this material. As a result, a special campaign is being planned to down-blend the off-specification HEU to LEU.

Three different scenarios for the blending of the surplus ^{233}U with off-specification HEU have been analyzed: (1) disposition of ^{233}U that is in storage at the Y-12 facility in Oak Ridge, Tennessee; (2) disposition of the CEUSP ^{233}U ; and (3) disposition of the entire ^{233}U inventory (i.e., all ^{233}U -containing materials). The ^{233}U in storage at Y-12 is primarily HEU and is similar to the material being considered for down-blending at SRS. The scenario for the CEUSP ^{233}U provides an analysis of the worst (in terms of ^{232}U content) material in the ^{233}U inventory. Finally, the scenario for the entire ^{233}U inventory provides an upper-bound analysis for disposition of ^{233}U with off-specification HEU. The results from these analyses are summarized in the following subsections. A schematic of the general option is shown in Fig. 4.17.

Table 4.15. Summary: Convert ^{233}U to LWR fuel

Application	Disposal
Acceptable ^{233}U feeds	Y-12 ^{233}U
Method to convert to non-weapons-usable ^{233}U	Isotopic dilution, radiation
Disposal site	YM-type repository
Criticality control strategy	Isotopic dilution
Technical description	Excess ^{233}U is dissolved in acid; purified; isotopically diluted with DU, natural or LEU; converted into UO_2 pellets; fabricated into fuel assemblies; and sent to power reactors as fresh fuel. The SNF is sent to the YMR.
Assessment	
Advantages	Clear path to final repository disposal
	Medical isotopes can be recovered during the purification process.
Disadvantages	Except for the ^{233}U stored at the Y-12 plant, this is an expensive option because existing fuel fabrication plants can not accept ^{233}U due to the radiation levels.
	The Y-12 ^{233}U inventory consists of very pure ^{233}U diluted with high-grade HEU. The radiation levels of this material are sufficiently low that it could be fabricated into fuel in existing facilities.
Evaluation	This is a potentially attractive disposition option for one small lot of ^{233}U which could be processed in existing facilities. It is an expensive option for the remaining ^{233}U because special fuel fabrication facilities would be required.

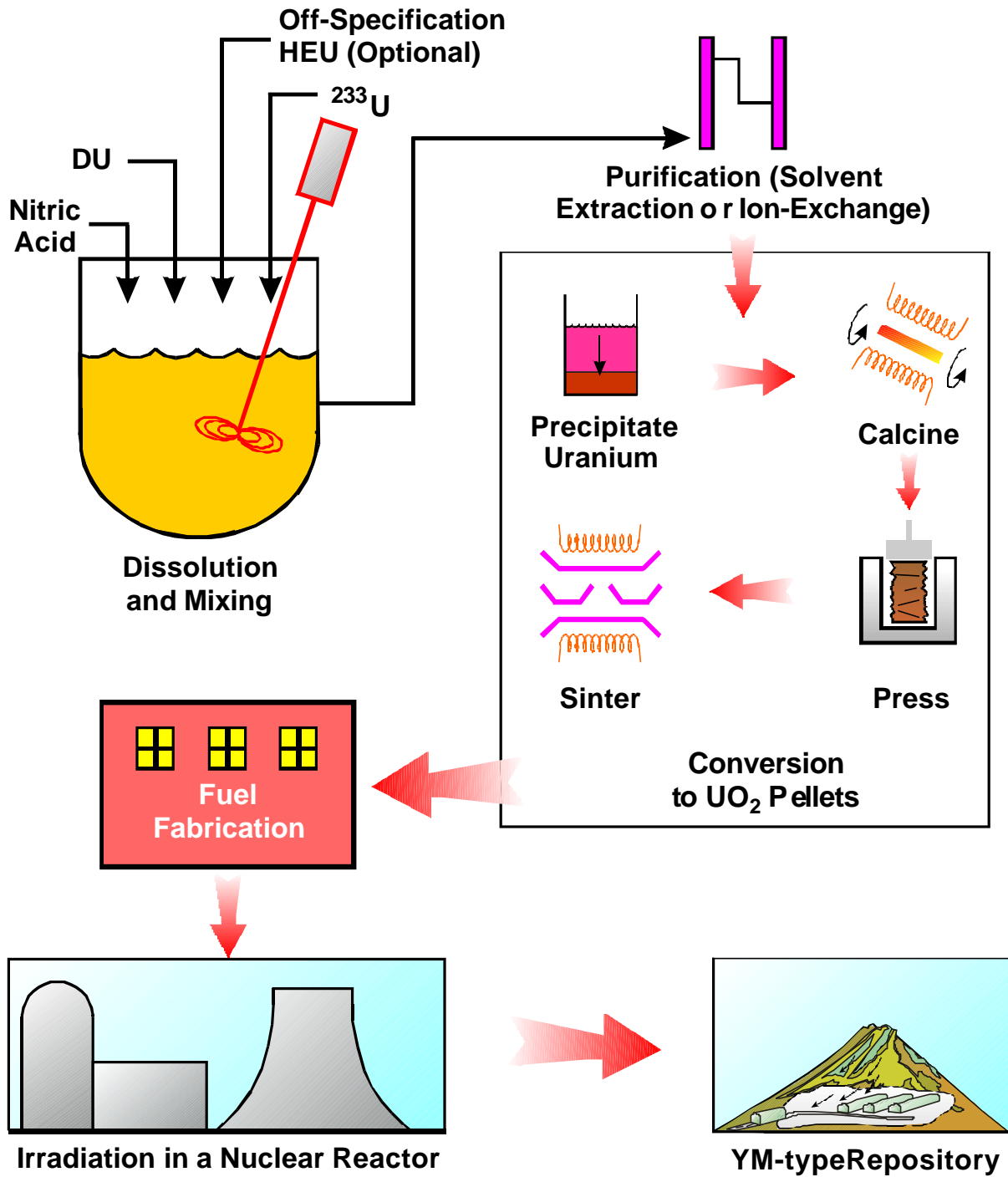

Fig.4.17. Conversion of ^{233}U to LWR fuel, irradiation, and disposal of the SNF in YM.

4.10.2 Past Experience

The United States has experience in the manufacture and irradiation of ^{233}U -based fuels. The Shippingport Atomic Power Station, located near Beaver, Pennsylvania, was the first large-scale central-station nuclear power plant in the United States. It was started up in 1957, was shut down in 1982, and was decommissioned over the ensuing few years (DOE July 1992). Shippingport was initially an enriched ^{235}U -fueled pressurized LWR, but it was converted in 1977 to an LWBR based on the ^{233}U -thorium fuel cycle.

To minimize the radiological dose to workers during Shippingport fuel fabrication, the ^{233}U nitrate solution, processed at ORNL, was purified by ion exchange to remove the ^{232}U decay products and to provide a window of time during which the radiation field from the material produced was significantly reduced. The resulting solution was then converted to oxide and shipped, not more than 1 week to 10 d following purification, to Bettis Atomic Power Laboratory for fuel fabrication in a relatively low radiation field. It is noteworthy that the largest radiation exposure of personnel under the Naval Reactors Program occurred in 1975. The combined cumulative dose to all navy program personnel was 15 times greater than the amount reported in 1994—primarily because of the fabrication of the LWBR core for Shippingport (Mangeno and Burrows March 1995). Some of the ^{233}U in inventory today is of better quality than the Shippingport material; however, a significant quantity of the current inventory has higher ^{232}U impurities and higher radiation levels than the material that was processed. The experience gained from handling ^{233}U materials indicates that control of radiation doses is the major issue.

4.10.3 Conversion of Off-Specification HEU and ^{233}U to LWR Fuel

DOE and the Tennessee Valley Authority (TVA) have signed a Memorandum of Understanding (MOU) regarding the conversion of SRS off-specification HEU to commercial nuclear reactor fuel. This MOU could lead to disposition of as much as 30 t of off-specification HEU (Nuclear Fuel February 10, 1997; McWhorter April 29, 1997). The HEU will be diluted with natural uranium in order to meet TVA LEU specifications.

It is anticipated that test fuel assemblies containing the down-blended, off-specification HEU will be fabricated by the spring of 1999. These assemblies will be irradiated for about 6 months in a reactor and then removed for testing. The results of these tests will be used to obtain permission from the NRC to use the down-blended, off-specification HEU in TVA nuclear reactors (McWhorter April 15, 1997).

The composition of the SRS HEU and that of the materials for the three scenarios studied are shown in Table 4.16. The SRS DU is ~0.27 wt % ^{235}U and ~99.73 wt % ^{238}U (McWhorter April 29, 1997). The SRS HEU will be down-blended with DU to obtain ~4.9 wt % LEU. It is estimated that about 108 t of SRS DU will be required. The resulting composition of the SRS LEU is presented in Table 4.17. Also presented in Table 4.17 are the compositions for the three proposed blends of materials containing ^{233}U (i.e., Y-12 ^{233}U , CEUSP ^{233}U , and all ^{233}U -containing materials) and the SRS LEU. For blending the Y-12 ^{233}U , no additional DU would be required. However, to maintain an enrichment of 4.9 wt %, for the examples of the CEUSP ^{233}U and all ^{233}U -containing materials, about 19.7 and 44.5 t of SRS DU would have to be added, respectively. In each of the scenarios analyzed, the fissile isotopes ^{233}U and ^{235}U are blended with the SRS LEU. Therefore, the enrichment is defined in terms of the equivalent ^{235}U enrichment and is given by the following formula:

$$\text{Equivalent } ^{235}\text{U enrichment} = \frac{\text{mass of } ^{235}\text{U} + \left(\frac{20}{12}\right) (\text{mass of } ^{233}\text{U})}{\text{total mass of U}} \times 100\% \quad (4)$$

This formula provides an estimate of the equivalent mass of ^{235}U for the ^{233}U present.

In Table 4.18, the proposed blends are compared with American Society of Testing and Materials (ASTM) specifications. These specifications are industry standards used by LWR fuel fabricators and are used to address three primary issues: (1) neutronics, (2) alpha activity, and (3) gamma activity.

4.10.3.1 Neutronics

Uranium-236 is a neutron poison, and the basis for its specification is rooted in neutronics considerations (Cagle June 25, 1997). The presence of ^{236}U in a fuel (above the specification) would require a special analysis of the fuel performance. For each of the scenarios examined, the ^{236}U content would be well above the specification. However, this off-specification condition is already being addressed by the SRS disposition program by its fabrication and testing of fuel assemblies for NRC approval. Additionally, the concentration of ^{236}U in the resulting LEU could be reduced by further blending the LEU with enriched, commercial-grade uranium.

Table 4.16. Composition of candidate materials for down-blending by mixing with SRS DU

Radionuclide	Composition (kg)			Total ²³³ U-containing materials ^{c,d}
	SRS HEU ^{a,b}	Y-12 ²³³ U ^c	CEUSP ²³³ U ^{c,d}	
²³² U	1.80×10^{-4}	4.80×10^{-6}	0.15	0.16
²³³ U	0	0.8	101.1	789.2
²³⁴ U	108	0.0	0.0	0.0
²³⁵ U	5,445	38.7	796.4	835.2
²³⁶ U	2,133	0.0	0.0	0.0
²³⁸ U	<u>1,314</u>	<u>3.1</u>	<u>145.0</u>	<u>174.9</u>
Total U	9,000	42.6	1,042.6	1,799.5

^aMcWhorter, D. L., April 15, 1997. Westinghouse Savannah River Company, Savannah River Site, Aiken, S.C., personal communication to A. S. Icenhour, Lockheed Martin Energy Research Corp., Oak Ridge National Laboratory, Oak Ridge, Tennessee.

^bThis material also contains ~200 disintegrations per minute plutonium and 11 ppm ⁹⁹Tc.

^cForsberg, C. W. and A. M. Krichinsky, January 1998. *Strategy for the Future Use and Disposition of Uranium-233: Overview*, ORNL/TM-13550, Lockheed Martin Energy Research Corp., Oak Ridge National Laboratory, Oak Ridge, Tennessee.

^dThe CEUSP material contains ~287 kg of cadmium.

Table 4.17. Composition of proposed blends

Radionuclide	Composition (kg)			
	Blended SRS LEU ^a	Blended SRS LEU and Y-12 ²³³ U ^b	Blended SRS LEU and CEUSP ²³³ U ^c	Blended SRS LEU and ²³³ U-containing materials ^d
²³² U	1.80 × 10 ⁻⁴	1.85 × 10 ⁻⁴	0.15	0.16
²³³ U	0	0.8	101.1	789.2
²³⁴ U	108	108	108	108
²³⁵ U	5,737	5,775.7	6,586.6	6,692.4
²³⁶ U	2,133	2,133	2,133	2,133
²³⁸ U	<u>109,100</u>	<u>109,103.1</u>	<u>128,891.8</u>	<u>153,654.8</u>
Total U	117,078	117,120.6	137,820.6	163,377.5

^aObtained by blending 9,000 kg of SRS HEU with 108,078 kg of SRS DU.

^bObtained by blending the SRS LEU and the 42.6 kg of Y-12 HEU.

^cObtained by blending the SRS LEU, 1,042.6 kg of CEUSP HEU, and an additional 19,700 kg of SRS DU.

^dObtained by blending the SRS LEU, 1,799.5 kg of ²³³U-containing materials, and an additional 44,500 kg of SRS DU.

Table 4.18. Comparison of proposed blends with ASTM specifications

Radionuclide or quantity	Specification ^a	Blended SRS LEU	Blended SRS LEU and Y-12 ²³³ U	Blended SRS LEU and CEUSP ²³³ U	Blended SRS LEU and ²³³ U-containing materials
²³² U	0.05 µg/g U	0.002	0.002	1.060	1.002
²³⁴ U	2,000 µg/g U	922	922	784	661
²³⁵ U	≤5 wt %	4.90	4.93	4.90	4.90
²³⁶ U	250 µg/g U	18,219	18,212	15,477	13,056
Alpha activity ^{c,d}	3,300 Bq/kg	2.58 × 10 ⁸	2.60 × 10 ⁸	1.32 × 10 ⁹	2.71 × 10 ⁹

^a“Standard Specification for Uranium Hexafluoride Enriched to Less Than 5% ²³⁵U,” ASTM Standard C996-96, American Society for Testing and Materials, West Conshohocken, Pennsylvania, 1996.

^bIncludes contribution from ²³³U as equivalent ²³⁵U.

^cThe alpha activity presented here is compared with the specification for neptunium and plutonium (3,300 Bq/kg U). For purposes of this comparison, the alpha activity is estimated from the amounts of ²³²U, ²³³U, ²³⁴U, ²³⁶U, and their daughters.

^dThe alpha activity for typical HEU is about 2.38 × 10⁹ Bq/kg U, while it is about 2.68 × 10¹² Bq/kg Pu for WGP.

4.10.3.2 Alpha Activity

The alpha activity specification is designed for the radiological protection of workers, particularly during fuel fabrication. High levels of alpha activity would dictate special handling and protective requirements. The alpha activity specification presented in the ASTM Standard is based on the activity of neptunium and plutonium in the material. For purposes of comparison, the alpha activity for the scenarios analyzed is estimated from the amounts of ^{232}U , ^{233}U , ^{234}U , ^{236}U , and their decay products. Because the alpha activity for the blended SRS LEU is significantly higher than the specification for normal LEU fuel fabrication, this high activity may dictate special handling requirements for the SRS LEU. The addition of the Y-12 ^{233}U to the SRS LEU increases the alpha activity only slightly, while the alpha activity is increased by about a factor of 5 with the addition of the CEUSP ^{233}U and about a factor of 10 with the addition of all ^{233}U -containing materials. The alpha activity varies with time, primarily because of the decay of ^{232}U and the ingrowth of ^{232}U daughters. For a material initially containing only ^{232}U , the alpha activity will peak after about 10 years of decay.

The alpha activity specification is for LEU LWR fuel fabrication. It should be noted that the alpha activity for typical HEU is about 2.38×10^9 Bq/kg U (Duerksen May 19, 1997) and is about 2.68×10^{12} Bq/kg Pu for WGP (Albright, Berkhout, and Walker 1997). There is a large experience base at DOE facilities in handling both HEU and WGP. In addition, there is a large experience base at commercial (i.e., NRC-licensed) facilities in handling HEU for U.S. Navy reactors and for research reactors. As a result, the high alpha activity estimated for the scenarios analyzed should not preclude the fabrication of LWR fuel.

4.10.3.3 Gamma Activity

The gamma activity of a material is a concern with respect to radiological protection of personnel. A large gamma activity can result in significant radiation fields during all aspects of LWR fuel fabrication and handling before to loading the fuel into a reactor.

A unique feature of ^{233}U is that it contains ^{232}U . The ^{232}U contaminant in ^{233}U can result in a large gamma activity and dose. A daughter of ^{232}U , ^{208}Tl , emits a 2.6 MeV gamma with a half-life of about 3 min. Similar to the alpha activity, the gamma activity will peak after about 10 years of decay. The concentration of the ^{232}U determines the gamma activity and ultimately determines the potential dose to workers. The ^{232}U content of the proposed blend of SRS LEU and Y-12 HEU would be well under the specification. However, for the CEUSP and all ^{233}U -containing materials blends, the ^{232}U specification would be exceeded.

4.10.4 Conclusions

Of the three scenarios considered, only the Y-12 ^{233}U appears to be a viable candidate material for disposition with the SRS off-specification HEU as LWR fuel. The resulting blend would be almost indistinguishable from the proposed SRS LEU blend and should have no significant impact on operations because of its unique characteristics (i.e., it is primarily HEU with a small amount of ^{232}U and ^{233}U). No legal barrier has been identified that would prevent the blending of the Y-12 ^{233}U with the off-specification HEU and DU.

For the CEUSP and all ^{233}U -containing materials, the ASTM specifications are significantly exceeded for both ^{232}U content and alpha activity. Hence, these materials present a radiological problem for both gamma and alpha radiation that likely could not be addressed by the current plans for processing the off-specification HEU to LWR fuel. Before their processing, these materials could be purified by removing the ^{232}U decay products, thereby reducing radiation levels and thus affording a window of opportunity for processing the ^{233}U in a lower radiation field. However, because the ^{232}U decay products would build up rather rapidly, such an option would require close coordination and strict schedules. It is unlikely that it would be possible to purify the material (by removing ^{232}U decay products), blend the resulting material with the off-specification HEU and DU, convert the blend to oxide, fabricate pellets and fuel, and install the fuel assembly in a reactor before the radiation levels increased significantly. Therefore, the CEUSP ^{233}U and all ^{233}U -containing materials are not viable options for blending with the SRS off-specification HEU. Furthermore, because of the high gamma radioactivity, it is likely (based on earlier experience) that only a custom-built, remote-operated, fuel-fabrication facility could convert these materials to LWR fuel.

4.11 DEEP BOREHOLE (DISPOSAL)

This section describes the deep borehole concept for geologic disposal of immobilized excess ^{233}U -bearing material. It is summarized in Table 4.19. The concept is based on a method of direct geologic disposal. Most of the discussion presented about this concept is based on a documented analysis by Lawrence Livermore National Laboratory (LLNL) for the disposition of WGP (Wijesinghe et al. August 23, 1996) and information provided by LLNL staff involved with that analysis (Halsey August 6, 1998; Wijesinghe August 6, 1998).

Table 4.19. Summary: Characteristics of deep borehole disposal

Application	Disposal
Acceptable ^{233}U feeds	All
Method to convert to non-weapons-usable ^{233}U	Immobilization and isolation in deep underground boreholes
Disposal site	Deep underground boreholes in geologically stable rock. (One borehole may be enough for the disposition of all excess domestic ^{233}U -bearing materials.)
Criticality control strategy	Chemical form and physical dilution
Technical description	Excess ^{233}U -bearing materials are packaged in canisters and placed about 2 to 4 km down into an underground borehole dug into geologically stable rock formation. The emplaced ^{233}U canisters are cemented in place, and then the isolation zone above the canisters in the borehole shaft is filled with appropriate backfill materials to provide a significant transport barrier from the biosphere.
Assessment	
Advantages	<p>Uses relatively few bulk processing steps</p> <p>Requires modest transportation requirements</p> <p>Offers fewer material accounting uncertainties and fewer opportunities for theft than other alternatives</p> <p>Provides potentially permanent isolation from the biosphere</p> <p>One borehole could be enough for the disposition of all ^{233}U-bearing materials declared excess.</p> <p>Could expect only small amounts of water migration from a deep-level emplacement region.</p>
Disadvantages	<p>Difficult for such a facility to gain public acceptance and obtain licensing approval because of perceived political sensitivities and problems in dealing with another federal geologic repository that would be following the WIPP and the YMR.</p> <p>Difficult to demonstrate subcriticality over geologic time</p>
Evaluation	Technically viable, but with major institutional problems. Siting and licensing a new waste disposal facility has historically required a multidecade, multibillion dollar effort.

4.11.1 General Description

The deep-borehole concept for geologic disposal of excess ^{233}U -bearing material includes the emplacement of the excess material into the lower part of one or more underground boreholes, each of which is drilled into a stable rock formation. The stability of the rock formation must be based on appropriate criteria that cover tectonic, hydrology, thermal, and geochemical characteristics. Application of deep boreholes as a disposition option for excess WGP was studied extensively by LLNL and is documented in *Alternative Technical Summary Report for Immobilized Disposition in Deep Boreholes*, UCRL-LR-121736 (Wijesinghe et al. August 23, 1996).

If the borehole disposition concept is adopted, ^{233}U -bearing materials would be emplaced and sealed in a region of stable rock that lies 2 to 4 km below the surface. This region is called the emplacement zone. A suitable rock identified for borehole emplacement is granite. Following emplacement, the region above the disposed material, extending from the top of the emplacement zone to the ground surface (and called the isolation zone), is filled and sealed with appropriate backfill materials. The isolation zone provides a large transport barrier to any disposed material.

As noted in the LLNL disposition study for WGP (Wijesinghe et al. August 23, 1996), the deep borehole-emplacement depths can be several thousands of meters greater than those of mined geologic repositories. At such depths, the groundwater is expected to be relatively stagnant and have temperatures of 75 to 150°C, pressures of 7,500 to 15,000 psi, and dissolved salt content of up to 40 wt %.

Table 4.19 summarizes the major features of the deep borehole application for the disposition of ^{233}U -bearing materials. Figure 4.18 shows the general features of the option.

4.11.2 Waste Form and Site Characteristics

Desired characteristics of waste forms suitable for immobilized disposition in deep boreholes include a stable solid form, high resistance to dissolution by subsurface brines, thermal stability, and compositional stability over the long periods of time. The host rock formation into which the excess material is buried should be a plutonic-metamorphic, crystalline rock (e.g., granite) in a tectonically, hydrologically, thermally, and geochemically stable region (Wijesinghe et al. August 23, 1996).

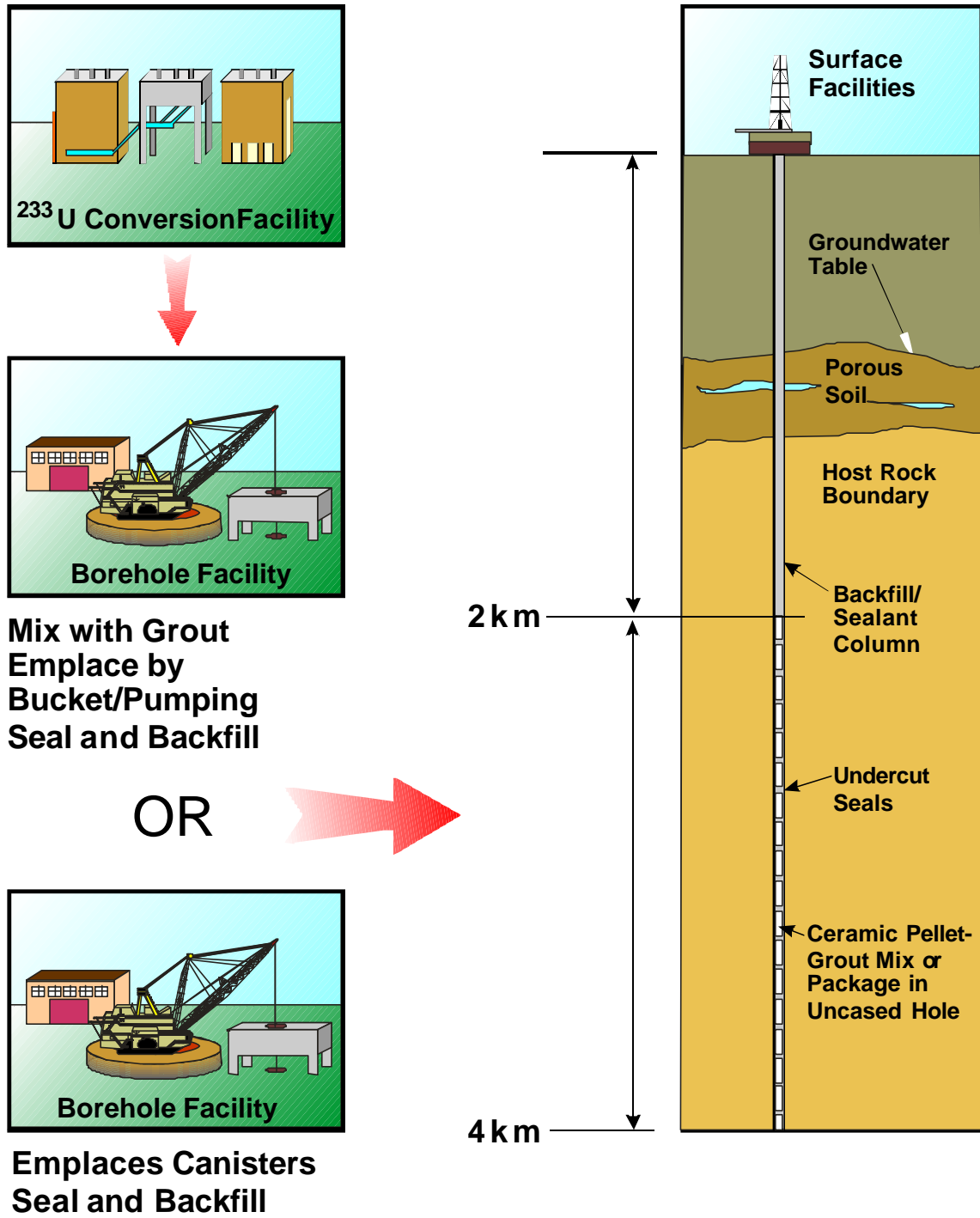

Fig.4.18. Borehole disposal of ^{233}U .

4.11.3 Deep-Borehole Alternative Applications

Two alternatives have been identified for the deep-borehole disposal option (Wijesinghe et. al August 23, 1996): immobilized disposition and direct disposition. Process flow diagrams for these alternatives are given in Fig. 4.19. Both alternatives require the transport of excess materials for disposition to a facility for conversion and repackaging before these materials are transferred to the borehole facility for emplacement, sealing, and backfill. In the immobilized disposition alternative, an additional step is included in the conversion phase to immobilize the material before borehole emplacement. The type of immobilization used would depend on the particular waste form and could include any (or a combination) of the following processes: grouting, encapsulation in ceramic pellets, or vitrification. Figure 4.20 illustrates the concept for the immobilized disposal of coated ceramic pellets in grout. For most of the domestic ^{233}U inventory, little material conversion and some repackaging would be necessary. Consequently, the appropriate application of the deep borehole option for any excess ^{233}U -bearing materials would be the direct disposition alternative.

4.11.4 Issues

An evaluation of the deep-borehole option for plutonium disposition was made with other alternatives and documented by DOE's Office of Arms Control and Nonproliferation in the report, *Final Nonproliferation and Arms Control Assessment of Weapons-Usable Fissile Material Storage and Excess Plutonium Disposition Alternatives*, (DOE January 1997). Several major advantages and disadvantages of the deep-borehole option have been identified.

A major advantage of the borehole option is that the isolation zone provides a large transport barrier to any disposed material. For all practical purposes, this material can be expected to remain permanently isolated from the biosphere. This feature assumes the availability and selection of a facility that is located in a geologically stable location which has stagnant groundwater at deep emplacement depths. The borehole option also uses relatively few processing steps in transforming the material into a form for disposition. Transportation requirements are also modest. The borehole option also has lower material accounting uncertainties and fewer opportunities for theft than other alternatives.

Primary disadvantages of the deep-borehole option are related to political sensitivities and public perception. The deep-borehole option requires the availability and selection of a facility that is located in a very geologically stable location that has stagnant groundwater at deep emplacement depths. It may be difficult for a deep borehole facility to acquire public acceptance and obtain licensing approval because of problems in these areas experienced from licensing geologic repositories like WIPP and the YMR. A borehole facility for the disposition of ^{233}U -bearing materials would be another federal waste geologic disposal facility that would require public review and approval for licensing. Another problem with the deep borehole option involves criticality verification. In the deep-borehole environment, it would be difficult to demonstrate or verify subcriticality of the disposed materials over geologic time.

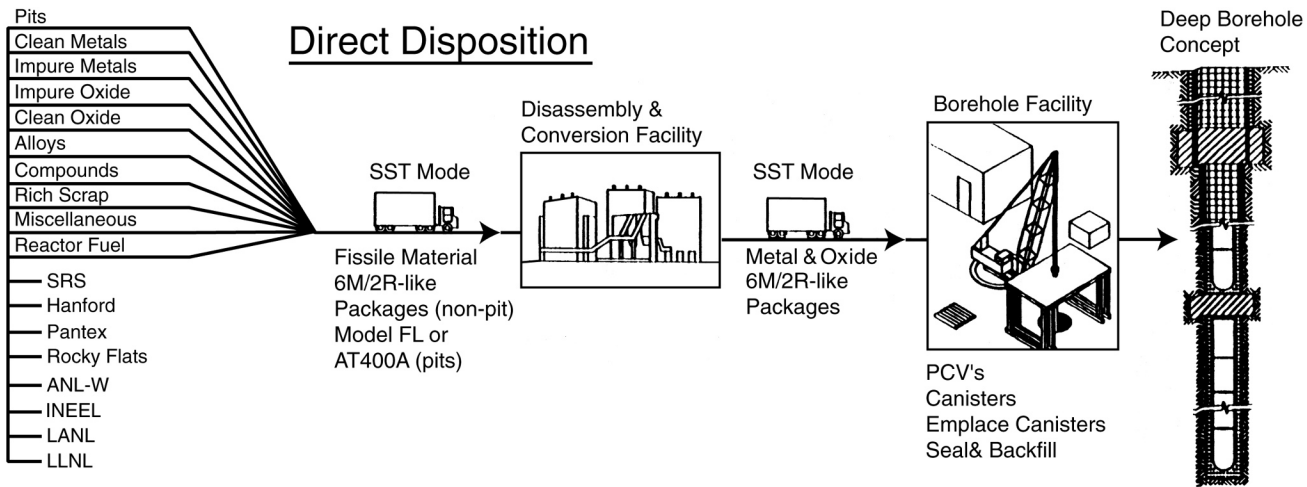
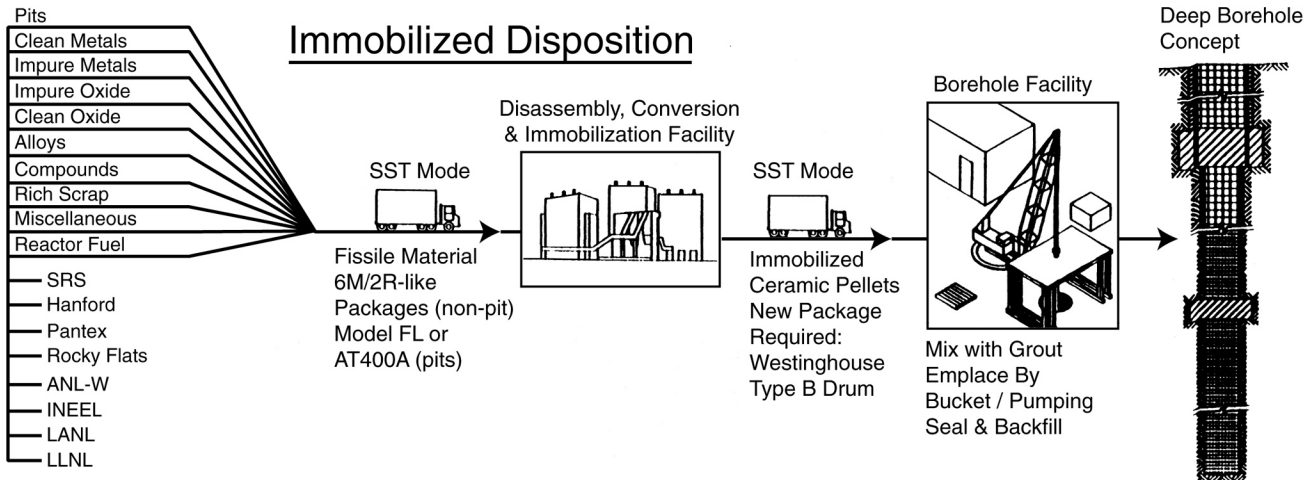

Fig. 4.19. Process flow diagrams for the immobilized and direct deep borehole disposition alternatives. [Courtesy of LLNL (Wijesinghe et al. August 23, 1996.)]

TYPICAL ARRANGEMENT OF DEEP BOREHOLE WITH EMPLACED CERAMIC PELLET-GROUT MIX

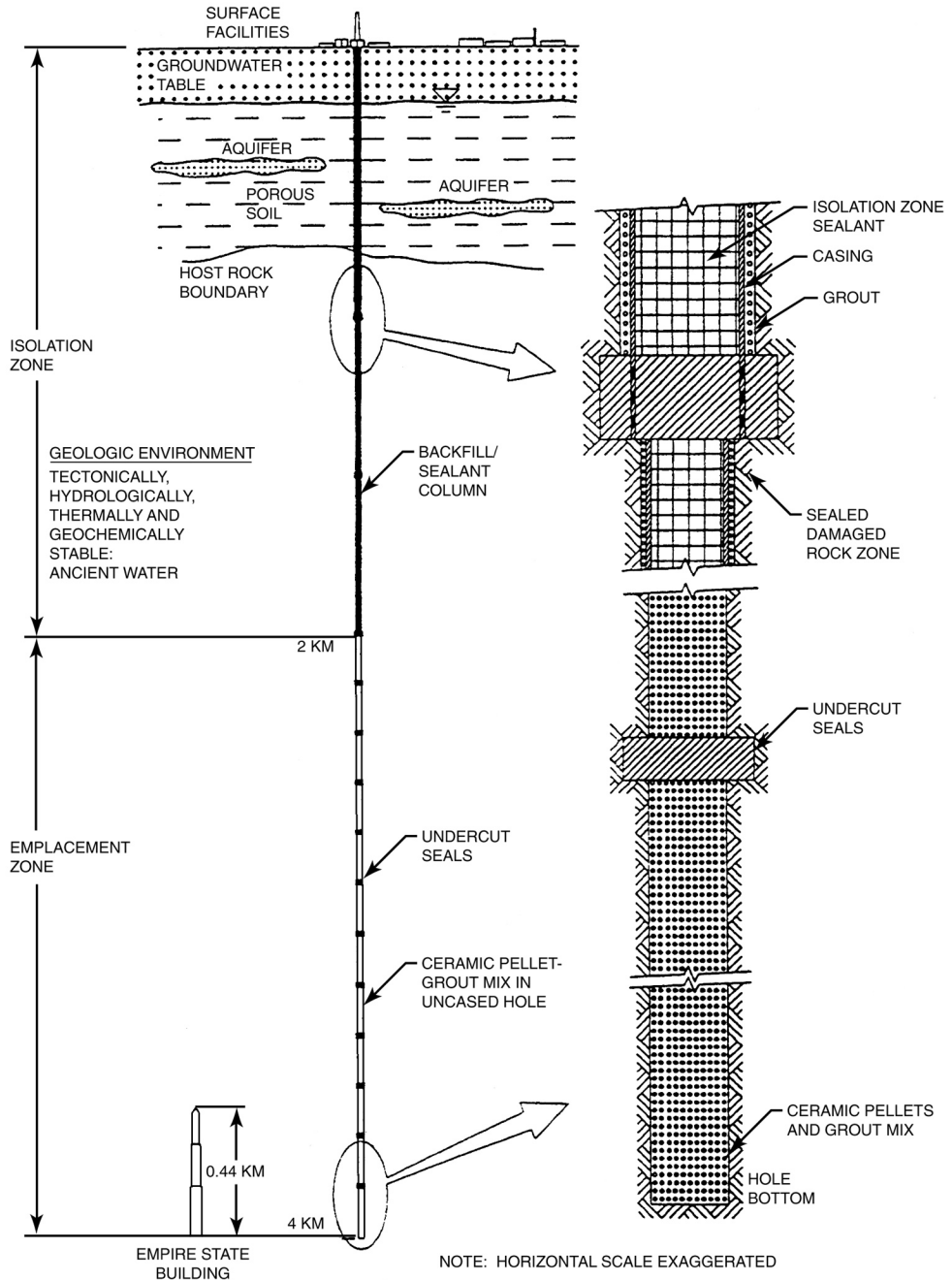

Fig. 4.20. The deep borehole disposal concept for immobilized disposal of coated ceramic pellets in grout.

4.11.5 Conclusions

The deep-borehole concept is a technologically viable option. The drilling technology exists, and some existing sites could be modified and developed to support this option. A major incentive for the deep-borehole option is that it potentially provides permanent isolation of the disposed material from the biosphere. However, there are significant hurdles to clear regarding politics, public approval, and licensing before the deep borehole option could be implemented for ^{233}U -bearing materials. It is not a practical option for the small quantities of ^{233}U .

4.12 GREATER CONFINEMENT DISPOSAL (GCD) (DISPOSAL)

The Nuclear Waste Policy Act (1982) and the Nuclear Waste Policy Amendments Act (1987) stipulate the requirements for disposing of radioactive wastes. HLWs are to be disposed of in a geologic repository (e.g., the proposed YM site). Many LLWs are suitable for near-surface disposal (e.g., trenches at the facility in Barnwell, South Carolina). However, some LLWs are not suitable for near-surface disposal (i.e., the GTCC or special-case wastes). To provide more isolation of and protection from these wastes, they may be disposed of at depths that are intermediate between those of near-surface disposal and those of a geologic repository. GCD was implemented by DOE to provide an intermediate-depth disposal option. It is no longer used. It may be a potential future disposition option for ^{233}U . Table 4.20 summarizes this option.

The Nevada Test Site (NTS) has, in the past, operated a GCD disposal facility. As discussed below, that facility is currently shut down. In addition, the NTS operates several large LLW burial sites. Among these sites are deep craters from nuclear weapons tests that are being used as disposal sites. Some of these disposal sites have technical characteristics similar to a GCD disposal facility. The NTS does not necessarily exclude the disposal of GTCC wastes. In the NTS waste acceptance document (DOE September 1996), DOE states:

“Disposition of commercial or DOE-generated waste designated as Greater-than-Class C, as defined in 10CFR61.55, may be evaluated for disposal on a case-by-case basis depending on the site-specific waste classification limits. This review may involve considering non routine disposal operations (i.e., controlling depth of disposal, considering other waste forms and package integrity, limiting the other types of wastes disposed nearby) or the development of a specific radiological performance assessment.”

Uranium-233 wastes could be classified as GTCC wastes. However, it is noted that the NTS does not accept TRUW. While ^{233}U is not legally defined as TRUW, it has many of the characteristics of TRUW.

Table 4.20. Summary: GCD of ^{233}U

Application	Disposal
Acceptable ^{233}U feeds	All
Method to convert to non-weapons-usable ^{233}U	Isotopic dilution
Disposal site	GCD facility
Criticality control strategy	Isotopic dilution, chemical dilution
Technical description	Excess ^{233}U is isotopically diluted with DU and disposed of in intermediate depth boreholes. Any one of several technologies may be used to isotopically dilute ^{233}U with DU.
Assessment	
Advantages	The construction costs for building a GCD facility should be less than for a repository.
Disadvantages	The single GCD facility (NTS) in the United States has been shut down by the regulator. No performance assessment (PA) has been done to determine the capability of this disposal option for alpha wastes including ^{233}U . Long-term performance of such a disposal option is unknown. Major development work would be required to develop the technology and address performance uncertainties.
Evaluation	Significant resources (time and money) would be required to determine if this is available option. There is no current or planned program to develop GCD site technology. A PA to determine if the single, existing, shutdown facility will require remediation will not be complete until FY 1999. No currently available data to indicate whether such a disposal site would be acceptable for ^{233}U .

GCD was used at the NTS from 1983 through 1989 to dispose of wastes considered unsuitable for shallow land burial. The GCD disposal units (Fig.4.21) consist of 36-m deep, 3-m-diam boreholes that were drilled into the desert alluvium. The boreholes were unlined, except for the top 3 m of each, which was lined with a corrugated steel culvert. A borehole was filled with WPs to a depth of about 21 m. The remaining 15 m of the borehole were filled with native soil and a 1.8-m long concrete monument that indicated the location and contents of the borehole. These boreholes were initially used to dispose of TRUW, high-specific activity tritium waste, irradiated fuel-rod cladding, and sealed sources. Wastes disposed of from September 1988 through 1989 contained only ^3H and DU. Thirteen GCD boreholes have been prepared. The first borehole, known as the GCD test, was experimental. Seven boreholes were filled and closed, while three more have been partially filled. Three other boreholes are empty (Shott et al. June 1995). During operation, there were no specific WAC (as established by a PA) for the facility. Instead, worker protection requirements (e.g., radiation protection) served as disposal criteria (Ginanni September 22, 1997; Cochran September 22, 1997).

In 1989, Nevada determined that the boreholes at the GCD facility were injection wells, which are prohibited by the state. Consequently, DOE suspended operation of the facility and currently has no plans to resume operations (Ginanni September 22, 1997). In 1994, a preliminary PA of the 4 TRU-containing boreholes was prepared to evaluate any effects on the public and the environment that could result from leaving these wastes in place. The final PA for the 4 boreholes is to be issued during FY 1999 (Cochran September 22, 1997).

If GCD were to be considered for ^{233}U disposition, the technology would have to be fully developed to meet current waste management requirements. Specifically, a detailed PA is required. The PA is a methodology to predict the long-term performance of a disposal facility. If the predicted performance does not match requirements, the design must be altered until the requirements are met. Current information does not indicate whether a GCD facility such as the earlier facility at Nevada would be acceptable for ^{233}U or what the requirements are for a ^{233}U waste form sent to such a facility. Waste management requirements would likely include acceptable chemical form and require isotopic dilution to avoid criticality issues. In particular, recent NRC (June 1997) studies suggest the need for isotopic dilution of any ^{233}U sent to a GCD facility. The NRC analyzed the long-term potential for nuclear criticality at the Envirocare Site in Utah for disposal of certain radioactive wastes that contained small quantities of HEU. The Envirocare site is a shallow-land, dry, disposal site that is somewhat similar to the NTS. The results of that analysis indicated the potential for nuclear criticality due to geochemical concentration of enriched uranium. Isotopic dilution would be the only viable method for criticality control if such a facility had significant quantities of fissile uranium isotopes.

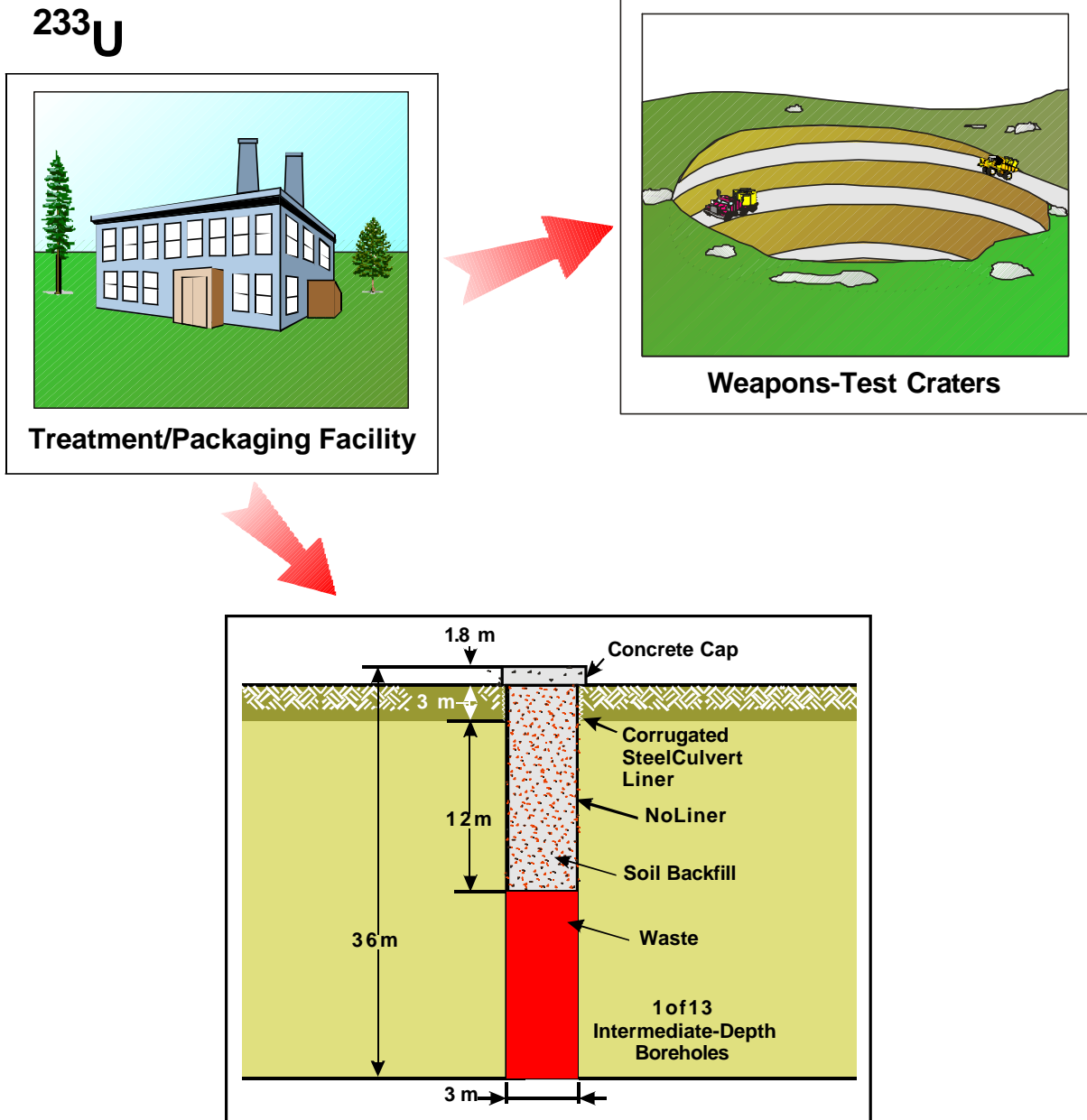

Fig. 4.21. GCD options for ^{233}U .

4.13 SPACE (DISPOSAL)

Disposal of excess ^{233}U -bearing materials in outer space is an option that potentially offers the goal of permanently isolating these materials from the earth's environment. Table 4.21 and Fig. 4.22 summarize the option. The possibility of disposal of radioactive waste materials in outer space has been studied extensively by the National Aeronautics and Space Administration (NASA), DOE, and European sources (Cosman January 1985).

Several evaluations have been made of space disposal of radioactive wastes, most notably those documented by Boeing Aerospace Company (BAC) (BAC 1981*a*, 1981*b*, 1982*a*, 1982*b*) for NASA. These studies identified and examined all of the major areas associated with the space disposal concept, including mission and operations analysis and systems integration and evaluation and various options for space disposal destinations, space transportation, flight support systems, launch sites, launch vehicles, orbit transfer systems, payload protection, and payload rescue techniques.

4.13.1 General Description

Space disposal of ^{233}U -bearing materials, like space disposal for other radioactive waste, would involve disposal by means of space transportation, not necessarily disposal in outer space itself. Several options have been identified with this method of disposal, and they are described below.

Disposal of ^{233}U -bearing materials in space would need to include those activities previously identified for the space disposal of radioactive materials (Coopersmith August 1992): solidifying the material (if necessary); embedding the material in an explosion-proof delivery vehicle; and launching that delivery vehicle into a designated orbit (earth, lunar, or solar). Different orbits are associated with several options for space disposal.

4.13.2 Waste Form Characteristics

Characteristics of waste forms suitable for space disposal have been identified and discussed in several sources (BAC 1982*b*, McCallum et al. January 1983, and Rice and Priest 1981). Waste forms suitable for space disposal should be based on chemical and physical compatibility with the required engineered protection systems. The major space disposal payload requirements identified for candidate radioactive wastes that also pertain to candidate ^{233}U -bearing materials include:

- Ease of fabrication into a desired form
- Economics
- High thermal conductivity
- High waste material loading
- Nuclear criticality control
- Resistance to leaching, oxidation, and thermal shock
- Strength of material (i.e., toughness compared with other waste forms)
- Strong thermochemical stability

Table 4.21. Summary: Space disposal

Application	Disposal
Acceptable ^{233}U feeds	All
Method to convert to non-weapons-usable ^{233}U	Isolation in outer space
Disposal site	Outer space (beyond earth's atmosphere)
Criticality control strategy	Chemical form
Technical description	Excess ^{233}U -bearing materials are packaged and placed into the cargo area of either a booster rocket or space shuttle for transport and disposition into outer space. Such materials would need to be solidified (if necessary) and embedded in an explosion-proof section of a delivery vehicle, which would be launched for disposition into a designated orbit (earth, lunar, or solar). The feasibility of this type of disposition is strongly dependent upon the technical capabilities of NASA space program.
Assessment	
Advantages	Provides a mode of permanent disposition that includes complete isolation from the earth's environment
Disadvantages	<p>Uncertainty in the stability of disposal orbits</p> <p>Risk of release of material to the atmosphere, either from a launch failure or a bad orbit, causing a potentially severe environmental impact with possible international implications</p> <p>Restrictive launch characteristics: waste payload system, launch system and site, and required orbit transfer system</p> <p>High energy requirements and total costs for space missions</p>
Evaluation	Viable only if there is significant incentive to use outer space for the disposition of other types of wastes as well as ^{233}U -bearing materials. Very high costs. Significant environmental, safety, and health (ES&H) questions about launch safety.

ORNLDWG98C-482R

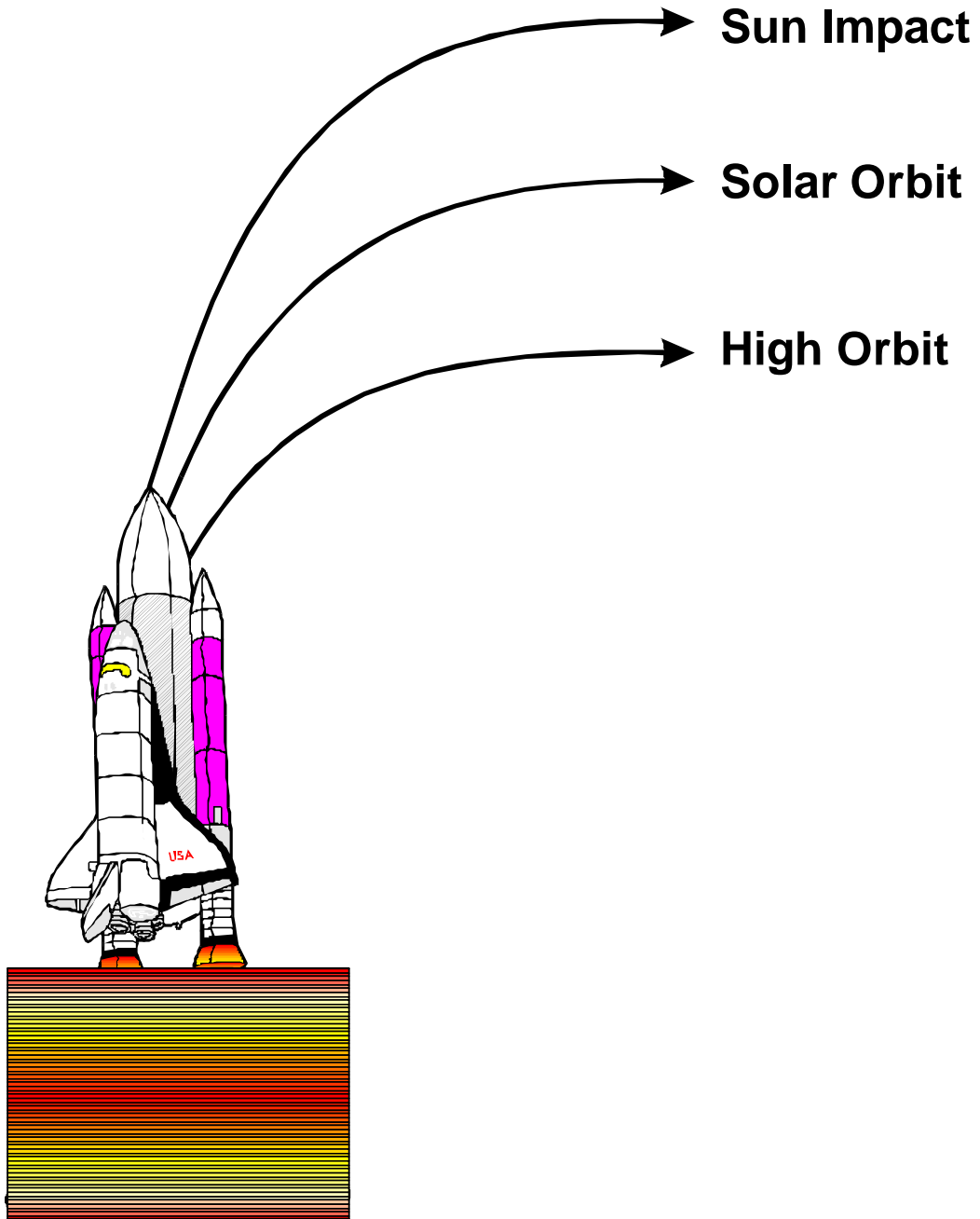

Fig. 4.22. Spacedisposal of ^{233}U .

One candidate material form that has been identified for space disposal is cermet, a waste form in which ceramic particles are uniformly dispersed throughout a metal iron-nickel-copper based matrix. As discussed in Aaron, Quinby, and Kobisk 1979, advantages of cermet include high material loading, high thermal conductivity, good corrosion resistance, good leach resistance, high durability, and high mechanical strength. These features make cermet an attractive shipping form. A comparison of cermet with other waste forms is provided in Table 4.22 (Rice and Priest 1981).

4.13.3 Space Disposal Options and Destinations

Varied disposal concepts under the space disposal option include:

- Disposal in the Van Allen Belt around the earth by Delta V rocket
- Disposal in high earth orbit by Delta V rocket
- Disposal by Space Shuttle in low earth orbit

For some disposal schemes, several alternative propulsion systems have also been proposed: mass drivers, solar sailing, and solar-powered thermionic propulsion (Cosman January 1985). One destination that has been selected in studies (BAC 1981*b*) as a reference has been the 0.85 astronomical unit heliocentric orbit destination, which did not require the removal of the protective shield container.

4.13.4 Issues

As described in various sources (notably, Coopersmith August 1992), the benefits of such a disposal system include the obvious safe, permanent disposal of the material. However, before this objective can be achieved, several concerns need to be addressed in the consideration of each space disposal option (Friedlander et al. 1991; Angelo and Buden 1987, and BAC 1982*b*):

- Stability of disposal or storage orbits
- Long-term risk of reentry of the material into earth's atmosphere
- Establishment of a supporting technology infrastructure
- Launch characteristics: waste payload system, launch system and site, and required orbit transfer system
- Rescue mission requirements

Disposal of all radioactive wastes (especially SNF) in space is not practicable because of the high launch rate required, resulting environmental impacts, high energy requirements, and high costs (Rice and Priest 1981). A proper selection of a mix of radioactive wastes for space disposal involves consideration of both the technical and economic factors affected by the energy requirements and total costs of the space mission(s). Technical factors considered in the waste-mix payload selection affect launch rates and heat loads. These factors include:

Table 4.22. Potential forms for nuclear waste in space disposal^{a,b}

Factor	ORNL cermet	ICPP glass ceramic	Sandia National Laboratory titanate ceramic	Borosilicat e glass	Metal matrix (coated particle)	Hot-pressed supercalcine
High waste loading	M	M	M	L	L	H
High thermal conductivity	H	L	L	L	H	L
Resistance to thermal shock	H	H	H	L	H	H
Thermochemical stability (fabrication temperature), °C	1450	1100	1100	1100	1000 ^c	1100
Resistance to leaching	H	H	H	H	H	H
Toughness	H	M	M	L	H	M
Applicability to commercial and defense (Hanford) waste mixes	H	L	L	L	H	L
Fabrication of waste into desired shape and size	M	L	L	H	M	L
Economics	M	M	M	H	L	M
Resistance to oxidation	L	H	H	H	L	H

^aFrom Rice and Priest 1981.

^bPotential is rated as H = high, M = moderate, or L = low.

^cCopper.

- Radionuclide composition and mass content
- Specific activities (and half-lives)
- Material transport properties
- Potential biological effects

A major issue with space disposal has been its difficulty in addressing concerns regarding a high (or at least significant) launch risk. The environmental impact of a future launch failure like that of the 1986 Challenger space shuttle disaster is potentially large, depending in large part upon the characteristics of the payload of radioactive material.

4.13.5 Conclusions

To ensure success, a wide range of technical choices needs to be evaluated along with a combination of societal, economic, and political factors that must be addressed (Coopersmith August 1992). At best, most of the concepts considered will not represent viable alternatives to earth-based disposal until well into the twenty-first century (Cosman January 1985).

Based on the economic and risk assessments made in studies of the space disposal of radioactive wastes (notably, Rice, Denning, and Friedlander February 1982), in order for the space disposal option to be viable for ^{233}U -bearing materials, it would need to be demonstrated that the overall long-term risks associated with this activity would be significantly less than the long-term risk associated with any earth disposal of the current total ^{233}U inventory. In addition, the long-term risk benefit associated with the space disposal of ^{233}U materials must be achieved within an acceptable short-term and overall program cost.

A major incentive for space disposal (McCallum et al. January 1983) is that it offers a perception of reduced risks rather than an actual significant reduction. Incremental costs for treating, storing, and transporting radioactive wastes and ^{233}U materials for space disposal are substantial. A likely space disposal scenario involving a payload of ^{233}U -bearing materials would be one in which the ^{233}U materials would be included in the payload along with other forms of radioactive waste.

Cost, schedule, and risk considerations eliminate this option as a viable option at the current time.

4.14 SUBSEABED (DISPOSAL)

Uranium-233 may be disposed of by converting it to a stable form and disposing of it under the ocean seabed. Placement under the ocean seabed can be accomplished using a drill ship or by tunnelling from small oceanic islands. Table 4.23 summarizes this option.

Table 4.23. Summary: Subseabed disposal

Application	Disposal
Acceptable ^{233}U feeds	All
Method to convert to non-weapons-usable ^{233}U	Isotopic dilution and/or geological isolation
Disposal site	Subseabed
Criticality control strategy	Isotopic dilution or geology
Technical description	Excess ^{233}U is converted to a stable waste form and disposed of under the ocean seabed.
Assessment	
Advantages	Recovery of final ^{233}U waste form would be a lengthy, costly, and visible to the international community. Creates the option for an international repository for SNF with reduced proliferation risks from civilian nuclear power.
Disadvantages	Development of a site is a decade-long, multibillion dollar effort requiring significant international cooperation and support.
Evaluation	The option is not viable for small quantities of materials such as ^{233}U because of high development costs, long development times, and complex regulatory issues that must be addressed.

This disposal option has been examined by multiple international programs. The results of such studies are that there are major technical (environmental) and long-term institutional (nonproliferation) advantages of such an option, but significant financial resources and multiple international agreements would be required to implement such an option. It is, thus, not a viable stand-alone option for the relatively small quantities of ^{233}U . A further description follows.

4.14.1 Engineering Description

There are two variants for subseabed disposal (Organization for Economic Co-operation Development 1988; Forsberg January 1993). The first is direct emplacement of the packaged waste from a floating offshore platform into the clay layer on the ocean seabed (Fig. 4.23). This option involves the use of current technologies for offshore drilling of oil. The second option is to construct a repository under a small oceanic island and under the nearby seabed. This option also includes the possibility of constructing a man-made island. The technology is well understood because many conventional mines are constructed under lakes and the ocean by continental seashores. Construction of an ocean island repository would be no different than construction of a conventional repository on land.

For both variants there are the requirements that sites with stable geology and appropriate geological formations for waste isolation be selected. There is also a specific set of technical requirements for an ocean island repository including a groundwater level near sea level, an isolated site, and a site where there is significant ocean-water mixing. The basis for these requirements are discussed herein. Large islands (such as the island of Hawaii) would not meet these requirements and would not be considered ocean-island repositories because disposal of wastes on islands of such size as Hawaii is similar to disposal of wastes on continents. Most candidate ocean islands that meet the requirements have land areas of only a few square kilometers. Many such islands are uninhabited because of the lack of fresh water.

4.14.2 Performance Capabilities

The objective of any radioactive disposal site is to isolate radionuclides from man and the environment until the radionuclides decay to nonradioactive elements or to such low levels of radioactivity that there is minimal risk to the public and environment. The expected failure mode of a repository is groundwater-leaching of the waste, movement of the groundwater to the open environment, and subsequent radioactive contamination of food or water. Conventional continental geological repositories and subseabed repositories have many of the same features to ensure waste isolation: (1) insoluble waste forms; (2) long-lived WPs; (3) deep underground burial [to prevent radionuclide release by natural phenomenon (glaciers, erosion, etc.) and man-made conditions (terrorists, accidents, etc.)]; (4) radionuclide exchange with local rock; and (5) geology with low groundwater flow.

The potential attraction of subseabed disposal is that the long-term repository performance may be significantly better than can be achieved by other disposal options (Fig. 4.24). There is an important caveat. The most important parameter in determining repository performance is the local site geology. A good site anywhere can provide high assurances of protection of public health and safety. The differences in long-term performance are described herein.

Deep Sea Borehole

Island Repository

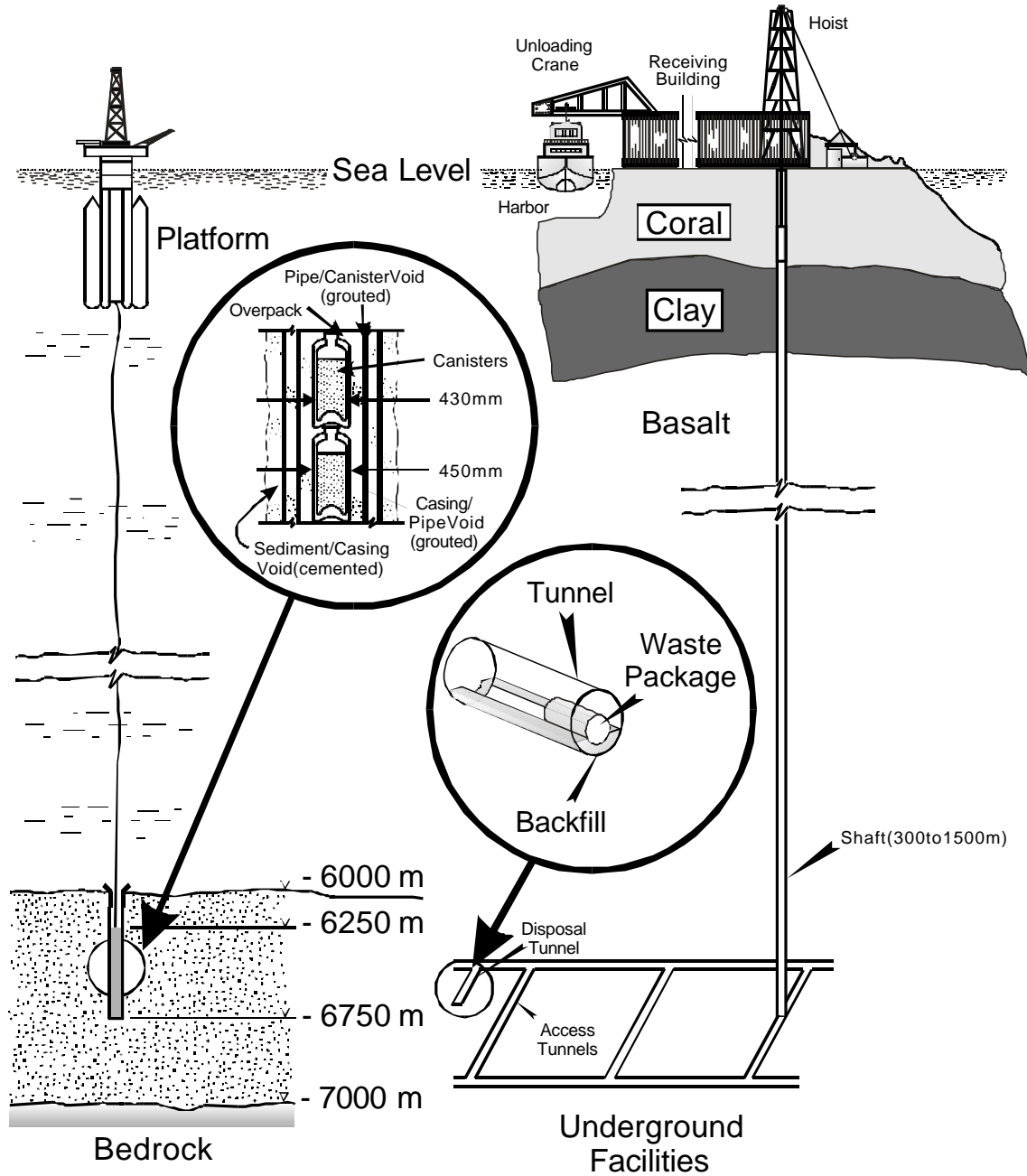
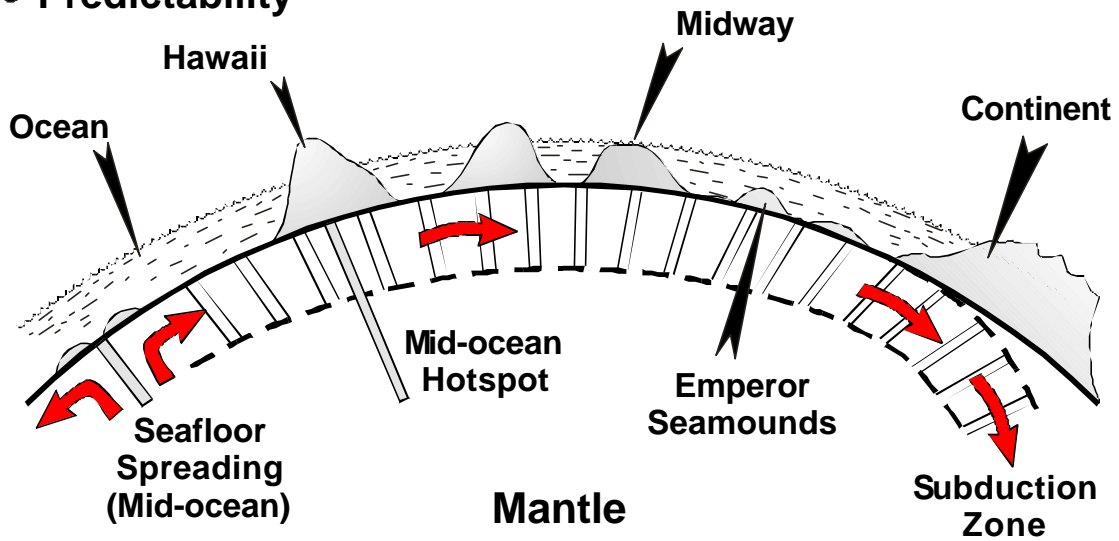
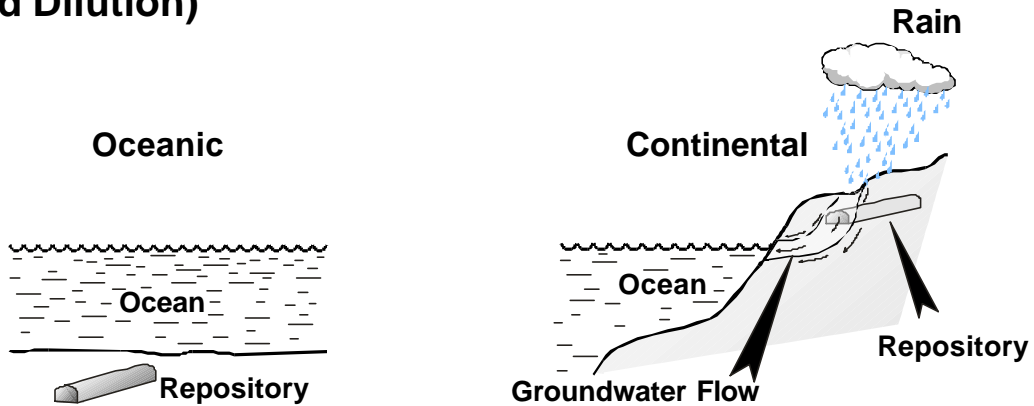

Fig. 4.23. Subseabed disposal options.

- **Predictability**



- **Intrinsic Isolation (No Gravity-Driven Water Movement and Dilution)**



- **Waste Form Stability**

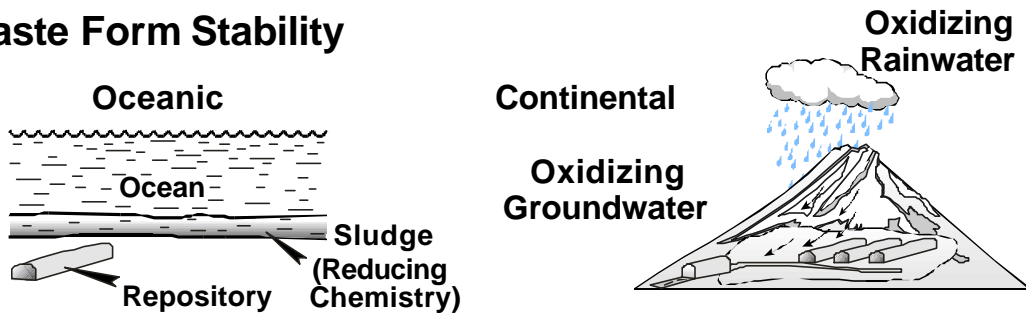

Fig.4.24.Characteristicsof seabed disposal options.

4.14.2.1 Predictability

The performance of a site is only as good as the capability to reliably predict performance. The ocean seabed and midocean islands have the most predictable environments on earth. Ocean seabed is formed at midocean spreading centers by volcanic activity. The seabed moves from these midocean spreading centers to subduction zones located at the edge of continents. At the edge of the continents, the seabed is subducted into the earth's crust. The process requires tens of millions of years.

Hot spots under the ocean seabed create volcanic islands such as Hawaii. Because of seabed spreading, the volcanic cones are carried by the ocean seabed into subduction zones. This results in chains of islands. For example, in the Hawaiian islands, the island of Hawaii is an active volcano. As one progresses northwest, the remaining islands are dead volcanos—each older and dead longer than the earlier island. The dead volcanos slowly sink into the ocean seabed which results in each island becoming smaller with time. The Hawaiian chain is above the level of the Pacific Ocean until it reaches Midway Island. Beyond Midway, the dead volcanos are totally submerged and are called the Emperor Seamounts. If one wants to predict how the island of Hawaii will look in x -million years, one examines an island or seamount that is x -million years old in the same island chain. The same is true of the oceanic crust.

Because the ocean seabed is under the ocean, changes in climate do not significantly impact subseabed conditions. This avoids the complications of predicting the effects of climate on a disposal site.

4.14.2.2 Intrinsic Isolation

Subseabed repositories have several mechanisms in addition to those of continental repositories that isolate radionuclides from the environment.

The ocean reduces the potential for radionuclide leakage from a repository because of geohydrological factors. The long-term natural mechanism for repository radionuclide release is by groundwater moving through the repository and then being transported to the open environment. There are two requirements for water movement: (1) a water-permeable rock (local geology) and (2) a hydraulic gradient to push the water through the rock from the waste form to the biosphere. The water table of the ocean and a small island is that of sea level; thus, there is little or no hydraulic gradient to move groundwater and any radionuclides dissolved in the groundwater. Groundwater moves on the continents because differences in land elevation above sea level create hydraulic gradients that cause water to flow to the sea. A waste disposal site, depending upon the local geology, can also create a thermal hydraulic plume from radioactive decay heat; however, many WPs are designed to last beyond the period of significant radioactive decay heat. The desirability of avoiding hydraulic gradients (hence, moving groundwater) is the basis for the island-repository requirement that the island have a groundwater table near sea-level.

The potential for human intrusion is significantly lower for island and subseabed sites.

- *Resources.* Ocean islands and the ocean subseabed are made of basalt—the most common rock on this planet which covers >50% of the planet's surface. Mineral deposits and oil are not found in this type of rock. In both environments, there is no fresh water, hence, no drilling for water.
- *Accessibility.* Small island repositories and subseabed sites are the most inaccessible locations on earth. Subseabed sites are accessible only with special deep-ocean capabilities. Small islands have no fresh water and require significant logistical support to conduct mining operations under such islands.

4.14.2.3 Independent Isolation Mechanisms

When very-high levels of safety or environmental protection are desired, a facility is designed (1) to minimize the possibility of failure and (2) to be fail safe. Fail safe, as an engineering concept, refers to designs that provide for the facility to converge to a safe state if unexpected failures or unfavorable conditions should occur.

The fail-safe characteristic of an ocean island or subseabed repository is the protective mechanism of diluting any unplanned releases of radionuclides from the repository by ocean dilution. This is the basis for the ocean island and subseabed requirement to avoid sites with limited ocean mixing. This environmental protection mechanism, which is unique to ocean-based concepts, is based on the observations that (1) the radioactive waste toxicity is small compared with the natural radioactive toxicity of the oceans and (2) very little of the natural or man-made radioactivity in the ocean reaches man via any pathway, and (3) ocean dilution usually reduces radiotoxicity to biologically insignificant levels.

The advantages of ocean dilution as an independent barrier for a repository have been explicitly noted by the National Academy of Sciences (December 1983) and British Royal Commissions (September 1976). The benefits have also been theoretically quantified. The analysis (Cohen 1980) indicates that if radionuclides were uniformly distributed in the upper continental crust at repository depths, the fraction of radionuclides that would enter the human food chain each year would be between 10^{-11} and 10^{-12} . For radionuclides dumped directly into the ocean, the fraction of radionuclides that would enter the human food chain each year is between 10^{-9} and 10^{-10} . This type of generic analysis indicates that ocean dilution as a barrier for radionuclide transport to man is within several orders of magnitude as good as continental geological disposal. The ocean is an excellent, independent, alternative mechanism, backup to either oceanic island or subseabed disposal.

As an aside, it is noted that the natural radioactivity in the ocean exceeds all radioactivity generated by man. It is estimated that if world electrical demand doubles, all electricity is from nuclear power, nuclear process is used for 100 y [10^5 GW (electric)-year of electricity is generated], and all radioactive wastes were dumped into the ocean, the average radiation dose to marine life would increase by <1% over natural background radiation levels.

4.14.3 Institutional Considerations

There have been many multinational studies of off-shore repositories to address political, economic, and environmental issues. Such studies have considered such repositories for national use, national repositories that accept foreign radioactive wastes, and international repositories. There are three major incentives to operate such a facility as an international repository for all types of radioactive waste:

- *Economics.* A large repository has economies of scale. It is particularly attractive for small countries to work together to minimize costs.
- *Environmental.* Different countries have different environmental standards. International repositories are expected to follow international standards that ensure high-levels of environmental protection.
- *Political.* An international repository can be used to forward nonproliferation goals by providing a location for disposal of SNF or fissile materials under appropriate safeguards (Weinberg 1985). This would be a large-scale implementation of the U.S. policy of accepting return of HEU SNF that was originally manufactured in the United States as part of our non-proliferation goals. Return of small quantities of foreign SNF has been controversial. Off-shore repositories offer the possibility of large-scale international disposal of SNF.

4.14.4 Issues

From technical, economic, and nonproliferation perspectives, there has been a continuous interest in ocean island and subseabed disposal. However, politically the option is difficult to implement. Several reasons have been identified for this perspective.

- *History.* Nuclear weapons testing was conducted in the Pacific by several countries. This resulted in serious long-term contamination of several islands, deaths of some fishermen, and created a large political legacy.
- *Institutional.* If an international repository is to be built, major international institutions must be created. This requires a major commitment by national leaders of multiple countries.
- *Technical.* The technical development requirements for either an ocean island repository or a subseabed repository are significant. With the ocean island repository option, there are significant siting constraints. For example, islands such as Bikini (a former test site) might be politically attractive, but they do not have acceptable geological structures. Other islands that meet the technical requirements may be considered politically unacceptable. The technical basis has improved recently with the French decision to declassify geological data on their two Pacific island underground test sites (International Advisory Committee 1998). These reports provide detailed data applicable to most Pacific islands.

4.15 DISPOSAL AS SNF (DISPOSAL)

The United States is formulating policies for the disposal of research reactor and other miscellaneous SNF. Much of this fuel contains HEU. Some of this fuel has very low burnup with low associated radiation fields. The CEUSP and some of the clean ^{233}U have higher radiation levels than does this SNF. The LWBR ^{233}U consists of unirradiated fuel assemblies, fuel rods, and pellets. It has the chemical and mechanical characteristics of nuclear fuel. These considerations raise the question of whether the material could be disposed of as SNF. Figure 4.25 and Table 4.24 summarize this option.

SRS is responsible for managing aluminum-clad miscellaneous SNF; INEEL is responsible for managing other miscellaneous SNF. A draft EIS (DOE December 1998) is being issued on long-term management options for aluminum-clad SNF—including low-burnup HEU SNF. Options that are being evaluated include direct disposal, aluminum melt-dilute (see Sect. 4.2.2), and aqueous processing. Some of these options involve isotopic dilution of the HEU with DU to convert the HEU to non-weapons-usable LEU. Other options, such as direct disposal, do not require conversion of weapons-usable material to a non-weapons-usable form. A decision on the preferred management option is expected in FY 1999. If direct disposal of HEU SNF is chosen, this becomes a potential option for some ^{233}U materials. If direct disposition is not chosen, the option may or may not be viable—depending upon whether a major problem with this option has been identified. If the option is considered viable for HEU SNF but is not chosen, costs to develop the option for ^{233}U will be much higher since the technology is not being developed for both HEU SNF and ^{233}U .

DOE is considering direct disposal of the LWBR irradiated SNF. The baseline option for this and other miscellaneous SNF is codisposal in a repository WP containing five canisters of HLW glass. Repository criticality safety issues are associated with disposal of this SNF. It is proposed to address these issues by limiting the amount of SNF per WP by including it in a package containing HLW but no other SNF (SNF Task Team Report March 1997). In the case of the LWBR SNF, a WP could contain up to (1) one ^{233}U LWBR blanket SNF assembly with 11.8 kg of ^{233}U before irradiation or (2) one ^{233}U standard LWBR SNF assembly with 21 kg of ^{233}U before irradiation. Detailed repository criticality analysis has not been done; thus, it is uncertain whether these quantities of material are acceptable. If unirradiated ^{233}U were to be disposed of, a similar approach would likely be adopted.

For disposal of separated ^{233}U , there are several issues.

- The repository criticality issue has not been addressed for the LWBR SNF; hence, it is uncertain whether this material is acceptable for the repository. Because this SNF will be in storage for many decades, there is not an immediate need to address this issue.

Package ^{233}U

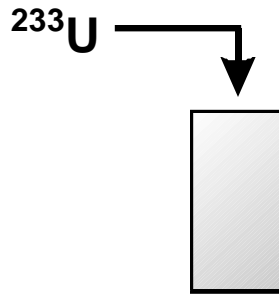

Steel Container

Place In HLW Package

77.5-in. OD

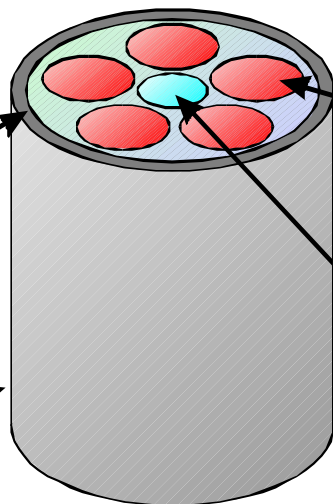

5 Each 24-in. Diameter HLW Glass Canisters

Repository Waste Package

17-in. Diameter Spent Fuel Canister

Disposal

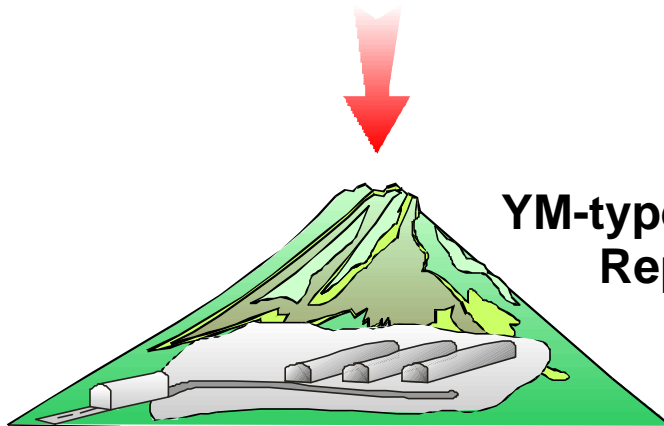

YM-type Geological Repository

Fig.4.25. Co-disposal of ^{233}U (defined as SNF)with HLW.

Table 4.24. Summary: Dispose as SNF

Application	Disposal
Acceptable ^{233}U feeds	All
Method to convert to non-weapons-usable ^{233}U	Isolation in geological repository
Disposal site	YM-type repository
Criticality control strategy	Package mass limit
Technical description	Excess ^{233}U is managed as HEU SNF by placing the material in special packages and then placing the packages into a WP containing multiple HLW canisters.
Assessment	
Advantages	Defined path to final repository.
Disadvantages	The ^{233}U does not meet the conventional definition of SNF. The option may not meet the Spent Fuel Standard
Evaluation	Major policy questions must be addressed. It is a low-cost option if DOE's SNF program adopts this strategy for disposal of miscellaneous SNF.

- The LWBR ^{233}U is not technically SNF. It has not been irradiated in a reactor. The legal status of treating the material as SNF is unclear. Like plutonium, it is a product of irradiation of targets with neutrons in nuclear reactors. Any determination on whether plutonium or ^{233}U could be considered SNF would be applicable to both. This has important implications for ^{233}U and plutonium because there are multiple regulatory requirements for managing SNF.
- The ^{233}U may not meet the SNF standard (see Sect. 4.6, "Waste Threshold Option").

Decisions on disposal of miscellaneous SNF in FY 1999 will likely determine whether this is a viable option for any ^{233}U . This is an expensive option to develop for a small quantity of material.

4.16 SHALLOW-LAND BURIAL (DISPOSAL)

Shallow-land disposal is disposal of wastes in a near-surface structure or trench. It is used to dispose of low-level radioactive wastes, municipal wastes, and some hazardous wastes. A characteristic of most LLW that may be disposed of in such facilities is that most LLW becomes nonradioactive in a relatively short time period. Waste isolation is required only for a limited time period. The quantities of long-lived radionuclides allowed in a shallow-land disposal site are typically limited to <100 nCi/g.

The radiation characteristics of ^{233}U are similar to those of TRU elements such as plutonium. The primary hazard is from alpha radiation. The United States requires geological disposal of wastes containing significant quantities of plutonium to minimize the risks from alpha radiation. By definition, plutonium wastes containing in excess of 100 nCi of plutonium per gram (about 1 ppm) require geological disposal. If the alpha activity is lower, shallow land disposal as LLW is acceptable. Based on health-physics considerations, a similar policy would be expected for ^{233}U . A ^{233}U disposition option based on this assumption is shown in Table 4.25 and Fig. 4.26.

Table 4.25. Summary: Shallow-land disposal as LLW

Application	Disposal
Acceptable ^{233}U feeds	All
Method to convert to non-weapons-usable ^{233}U	Chemical dilution
Disposal site	Shallow-land disposal
Criticality control strategy	Isotopic dilution and chemical dilution
Technical description	Excess ^{233}U is diluted by a factor of 100,000 with inert materials, DU is added, and the mixture is disposed of as LLW in a shallow-land disposal site.
Assessment	
Advantages	Meets the Spent Fuel Standard.
Disadvantages	High costs are associated with processing and there are significant uncertainties on how it would be done. Significant institutional questions on the acceptability of dilution as a method to change the classification of a waste form.
Evaluation	There are major institutional issues with this option compared to most other disposition options.

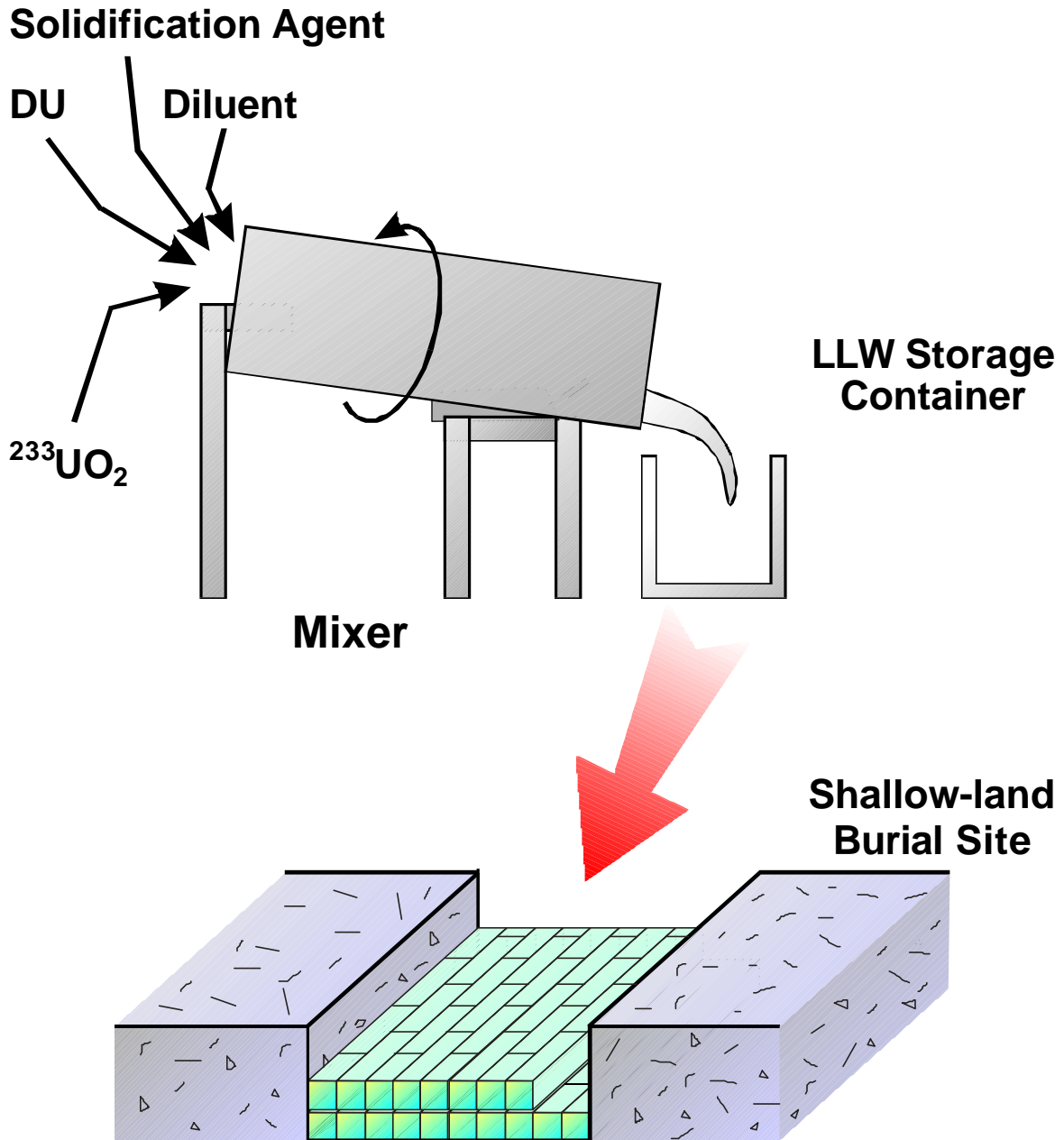

Fig. 4.26. Disposition of ^{233}U by dilution to LLW (<100 nCi/g) with shallow-land disposal.

The specific activity of ^{233}U is 9.6×10^6 nCi/g. To dilute ^{233}U to alpha-radiation levels allowed in shallow-land disposal facilities, the ^{233}U would have to be diluted by about a factor of 100,000. Assuming that the soil density is 2 g/cm^3 , the waste volume would be $\sim 50,000 \text{ L/kg}$ of ^{233}U .

Diluting ^{233}U with large quantities of other materials would be a significant engineering task; however, the difficulty of large-scale mixing operations and the large quantities of diluent required suggest that the diluted ^{233}U would meet the Spent Fuel Standard. Based on recent analysis of shallow-land burial grounds by the NRC (Toran et al. June 1997), DU would need to be added to the waste for criticality control. It would probably not be necessary to isotopically mix the ^{233}U with the DU. The different uranium isotopes could be physically mixed with the solidification agent. The natural mechanisms of uranium dissolution and transport would be expected to isotopically mix the uranium isotopes over time.

Several factors suggest that this option would be expensive and difficult to implement compared to other ^{233}U disposition options.

- *Definition of acceptable ^{233}U concentrations in LLW.* The dividing line on the allowable content of alpha-emitting radionuclides in LLW to be disposed of in a shallow-land burial ground was developed for plutonium. Uranium-233 was not considered when this dividing line was established. Uranium in oxidizing environments, as is often found in shallow-land disposal sites, is more mobile than plutonium in groundwater. If large quantities of ^{233}U were to be disposed of, an evaluation of the acceptability to dispose of LLW containing $<100 \text{ nCi/g}$ would be required. There is a potential that the allowable concentration of ^{233}U acceptable for shallow-land burial would be lower.
- *Dilution as a waste management strategy.* Dilution of radioactive waste to change the waste classification and allow shallow-land disposal is restricted unless there are special conditions. Any decision on ^{233}U could have a large institutional and economic implications for the disposal of TRUW since there are large quantities of TRUW with somewhat $>100 \text{ nCi/g}$ of TRU elements. Consequently, addressing the institutional issues with this option would be complex.
- *Economics.* The option has high processing and potentially high transport and disposal costs. This is a direct result of the large final waste volumes. The costs of shallow-land disposal is strongly dependent on the site. Currently, the NTS accepts wastes with characteristics that are closest to ^{233}U (bomb debris) and that have low disposal costs. For this favorable site, the cost is $\$265/\text{m}^3$ ($\$7.50/\text{ft}^3$). This implies ^{233}U disposal costs in excess of $\$13 \times 10^6/\text{ton}$ of ^{233}U .

4.17 ELECTROMETALLURGICAL PROCESSING (STORAGE AND DISPOSAL)

Uranium-233 may be down-blended with DU using an electrometallurgical process to produce a uranium metal form for (a) disposal at a YM-type or WIPP-type repository or (b) a long-term storage. Table 4.26 summarizes the option. Figure 4.27 shows the process

Table 4.26. Summary: Electrometallurgical process

Application	Storage, disposal
Acceptable ^{233}U feeds	LWBR, Clean, CEUSP
Method to convert to non-weapons-usable ^{233}U	Isotopic dilution of ^{233}U
Disposal site	YM- or WIPP-type repository
Criticality control strategy	Isotopic dilution
Technical description	^{233}U oxides converted to metal with lithium. ^{233}U and DU metal dissolved in molten salt. Uranium metal electroplated on cathode as final product for storage and disposal.
Assessment	
Advantages	May use partly completed facility at Argonne National Laboratory (ANL) (West)
Disadvantages	It is unknown if the product (metallic uranium) can meet repository WACs.
	Complex process
Evaluation	A version of the process is under development to process SNF where the uranium is recovered for reuse. There are major technical and institutional uncertainties on whether the process is viable for ^{233}U where the waste form is uranium metal

Reduction to Metal

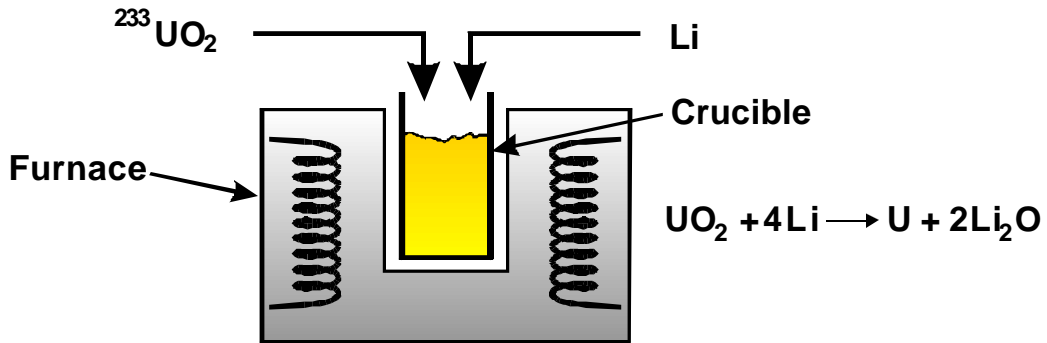

Dissolve in Salt/Electrolytic Recovery of Uranium Metal

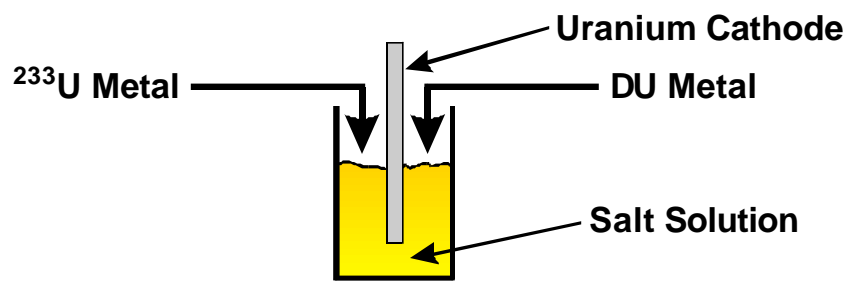

Weld Lid

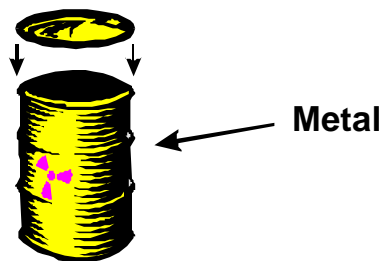

Storage (Use/Throw)



Existing ^{233}U Waste Storage Facility

Disposal

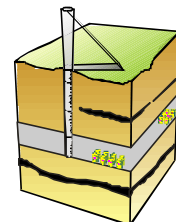

WIPP or YM-type Geological Repository

Fig.4.27. Disposition of ^{233}U by isotopic dilution with DU using the electrometallurgical process.

The original process was developed at ANL to recycle uranium and actinides from sodium-bonded, breeder reactor, SNF into new nuclear fuel. In the electrometallurgical process, metallic SNF is dissolved in a molten lithium-chloride—potassium-chloride (LiCl-KCl) salt solution. Uranium metal is recovered from this molten salt by electrolysis for eventual refabrication into fuel for recycling back into the reactor. The process is currently being investigated for another use—processing certain DOE SNF (National Research Council 1998) into waste forms acceptable for disposal in a YM-type repository. The uranium from the SNF is recovered for future use while the fission products and actinides are converted into acceptable repository waste forms. For this application, the ^{235}U is to be down-blended with DU in the process to produce LEU as a waste or storage form.

For down-blending of ^{233}U , the ^{233}U and DU metal would be dissolved in the molten salt and then the ^{233}U and the DU would be codeposited on the cathode in an electrolytic cell as uranium metal. The uranium metal would be the final product for storage or disposal as a waste form.

The electrometallurgical process is based on the dissolution of the elemental (metal) actinide fuels in LiCl-KCl molten salt. For those feed materials that are not elemental (metallic) uranium, a front-end process must be used to reduce the actinide compounds in the fuel material to the elemental state which can then be dissolved in the molten salt. This requires additional front-end processing for essentially all the ^{233}U in the inventory:

- *Clean and CEUSP ^{233}U* . The clean and CEUSP ^{233}U are in the form of uranium oxides. These forms would be processed using the same methods developed for oxide SNF. Typically, for oxide fuels, elemental lithium is used as the reductant to convert the uranium oxide to uranium metal. The oxidized lithium is then converted back to the elemental state for use in the next reduction cycle. Stainless steel and Zircaloy cladding are not dissolved by this process. The fuel is chopped so that the fuel meat can be leached from the Zircaloy or stainless steel hulls by the molten salt. The hulls are then managed as solid, LLW and discarded.
- *LWBR ^{233}U* . This material is in the form of a high-fired U-Th oxide. It is proposed (J. Laidler March 5, 1999) that LWBR fuel could be processed by chopping the fuel rods to expose the pellets, grinding the pellets to submicron size to make it more reactive with the elemental lithium, reducing the uranium and thorium oxides with lithium metal to the elemental state, and then dissolving the uranium and thorium in the molten salt mixture.

With current technology, it is estimated that ~1 kg/d of uranium could be processed. Some laboratory-scale experiments have demonstrated processing “low-fired” U-Th oxide ceramics. Questions still must be resolved as to whether the process could, in a reasonable time, convert the “high-fired” ceramics from the LWBR ^{233}U oxides to metal. It has been demonstrated that the uranium could be separated from the thorium in the electrolytic cell by adjusting the electrolytic-cell deposition conditions.

This process is probably capable of treating the ^{233}U inventory, including the LWBR ^{233}U . However, there are technical uncertainties that would strongly impact economics. There have been no full system tests processing high-fired ceramic fuel pellets. The process is complex compared to most other alternative processes for down-blending ^{233}U .

Moreover, there are significant uncertainties if the uranium product is to be a waste. In all other uses of this technology, the uranium is a product for reuse. No testing of such a uranium-metal waste form for a YM-type repository has occurred. It is an unusual waste form. For the CEUSP ^{233}U , which contains cadmium, it is unclear whether the final product would be acceptable to a YM-type repository which prohibits chemically hazardous waste forms. It is unknown too, if ^{229}Th (the isotope with potentially useful medical applications) could be recovered during processing of the clean or CEUSP ^{233}U . Uranium metal is allowed as a storage form although U_3O_8 is preferred because it is less chemically reactive.

5. CONCLUSIONS

Alternative storage and disposition options have been identified and described. Each option has different technical, institutional, schedule, and economic characteristics. All of the storage and disposal options could be implemented; however, the resources (financial, technical, time, and institutional) to implement the different options vary by orders of magnitude.

5.1 SPECIAL CHARACTERISTICS OF ^{233}U

There are several important caveats when considering ^{233}U storage and disposal options.

- *Characteristics.* Uranium-233 has fundamentally different characteristics than HEU and plutonium. With modern ES&H requirements, most of the ^{233}U will require hot-cell processing because of the buildup of ^{232}U decay products that emit high-energy gamma rays. Storage and disposition options suitable for HEU or plutonium are not necessarily suitable for ^{233}U .
- *Quantities.* The quantities of ^{233}U are small compared to HEU and plutonium. In total, there is <2 t of uranium in somewhat <20 t of material.
- *Categories.* There are three categories of ^{233}U with fundamentally different characteristics: clean, CEUSP, and LWBR ^{233}U . Many storage and disposal options are only viable for one or more categories.
- *Institutional constraints.* There are a set of unique institutional issues associated with ^{233}U disposition options because ^{233}U is the orphan fissile material. Much of the institutional structure that exists for HEU and plutonium does not exist for ^{233}U . This includes such items as a lack of an official definition of weapons-usable ^{233}U to constraints on disposal sites because enabling legislation did not consider the existence of ^{233}U materials or wastes.
- *Criticality control strategy.* Criticality control strongly influences costs and feasibility of various disposition options. In many cases, adding additional DU to minimize nuclear criticality constraints minimizes costs by minimizing waste volumes.

5.2 STORAGE AND PROCESSING OPTIONS

There are three storage strategies: (1) store as weapons-usable material for future use, (2) store as non-weapons-usable material for future use, and (3) store for future waste disposal. Weapons-usable ^{233}U must be stored in a Category I facility to prevent potential theft of material. If the ^{233}U is to be stored as non-weapons-usable material for future use, it must be isotopically diluted to <12 wt % ^{233}U in ^{238}U . Isotopically diluted material may be stored in facilities with industrial-type security. If the ^{233}U is to be stored as a waste, it should be isotopically diluted to 0.66 wt % ^{233}U in ^{238}U to convert it to non-weapons-usable material and minimize the potential for nuclear criticality. This material may be stored in existing ^{233}U waste storage areas with ultimate disposal in a WIPP-type geological repository.

Five technologies have been identified for isotopically diluting ^{233}U with DU. Two processes have been used on a large-scale: (1) aqueous dissolution and (2) dry blend with sintering. Three processes have been demonstrated in the laboratory using uranium, but not on an industrial scale: fusion melt, uranium-aluminum alloy, and electrometallurgical. The borate fusion melt process may be the lowest cost process to isotopically dilute ^{233}U with DU—if this is the only goal. The uranium-aluminum process can not handle LWBR ^{233}U because this ^{233}U contains large quantities of ThO_2 which is incompatible with the process.

5.3 DISPOSAL OPTIONS

Seventeen disposal options were identified. Each of the disposal options has different characteristics:

- The HLW option has the fewest institutional constraints of any option. The disposal costs of the LWBR ^{233}U may be high due to complications from the thorium in this feed material.
- The uranium-aluminum melt blend options depend upon successful development of the technology for treating aluminum-clad SNF. The option can not process LWBR ^{233}U .
- The aqueous process option is the only fully demonstrated process, is the most versatile option which allows for the recovery of special isotopes, and can produce multiple waste forms that are acceptable for disposal in a YM- or WIPP-type disposal facility. There are cost uncertainties.
- The borate-fusion melt option is probably the lowest-cost option for isotopically diluting ^{233}U , but there are technical uncertainties that could impact costs as well as institutional issues associated with disposal. It is also a potential pretreatment option to place ^{233}U in HLW tanks.
- The grind, dry-blend, and sinter option is potentially a lower cost option.
- The waste threshold option is probably the lowest-cost disposal option for the LWBR ^{233}U and a low-cost option for other ^{233}U . There are policy issues associated with this option.
- The can-in-canister option is conceptually identical to the can-in-canister plutonium disposition option. Because of the radiation levels associated with the ^{233}U , the plutonium facility could only process the LWBR ^{233}U .
- The RH TRUW processing option is potentially attractive if DOE builds an appropriate RH TRUW facility. No such facility is planned in the near term.
- The CH TRUW processing option is potentially attractive if DOE builds an appropriate CH TRUW facility. No such facility is planned in the near term.
- The LWR fuel option for ^{233}U has been demonstrated in the past. Because of the radiation levels of this feed material, existing fuel fabrication facilities can not process ^{233}U . A new custom-built facility would be needed. This would include hot-cell handling facilities. It is an expensive option. There is one exception to this conclusion. The Y-12 ^{233}U is HEU with small quantities of high-purity ^{233}U . It may be convertible into LWR fresh fuel without special facilities.

- The borehole-disposal option is identical to that proposed and then dropped for disposal of plutonium. The ^{233}U variant has the same advantages and disadvantages as the plutonium borehole option. It is a long-term and expensive option if used to dispose of a single waste.
- The GCD option is highly uncertain. It is unclear whether this option can meet current environmental requirements for disposal of long-lived radioactive materials.
- The space-disposal option has a very high cost and would require many years to develop. There are serious questions about rocket-launch safety.
- The subseabed disposal option is environmentally attractive, but it is a long-term and an expensive option if used to dispose of a single waste.
- Direct disposal of ^{233}U as SNF is potentially a low-cost option; but, there are questions whether this option meets the Spent Fuel Standard. Only the LWBR ^{233}U is a potential candidate for this disposal option.
- Disposal of ^{233}U as LLW (after dilution by a factor of 100,000) has major technical, cost, and institutional barriers.
- Processing and disposal of the ^{233}U electrometallurgical process is complex. It is unclear whether the final product is acceptable for YM-type repository disposal.

For all disposal options, there are multiple regulatory and other institutional issues that must be addressed. Those disposal options that coprocess ^{233}U with other waste forms have the fewest regulatory uncertainties. These include HLW glass disposal, the uranium-aluminum melt-dilute options, and can-in-canister.

6. REFERENCES

- Aaron, W. S., T. C. Quinby, and E. H. Kobisk, 1979. "Development of Cermets for High-Level Radioactive Waste Fixation," pp. 164–168 in *Ceramics in Nuclear Waste Management*, CONF-790420-10, DOE National Technical Information Service, Oak Ridge, Tennessee.
- Adams, T. M., H. B. Peacock, Jr., and F. C. Rhode, September 9, 1998. "Microstructure and Physical Metallurgy in Melt-Dilute Treatment Technology Development," pp. 23–30 in *Proc. Third Topical Meeting on DOE Spent Nuclear Fuel and Fissile Materials Management*, Charleston, South Carolina, September 8–11, 1998, American Nuclear Society, La Grange Park, Illinois.
- Albright, D., F. Berkhout, and W. Walker, 1997. *Plutonium and Highly Enriched Uranium 1996: World Inventories, Capabilities, and Policies*, Oxford University Press, Inc., New York.
- Angelo, Jr., J. A. and D. Buden, 1987. "Post-Operational Disposal of Space Nuclear Reactors," pp. 265–274 in *Proc. of Symposium Waste Management '87, Tucson, Arizona, March 1–5, 1987*, Vol. 1, University of Arizona, Nuclear Engineering Department, Tucson, Arizona.
- Barlow, M. W., September 9, 1998. "The Alternative Technology Program for Aluminum Research Reactor Spent Fuel," pp. 1–5 in *Proc. Third Topical Meeting on DOE Spent Nuclear Fuel and Fissile Materials Management*, Charleston, South Carolina, September 8–11, 1998, American Nuclear Society, La Grange Park, Illinois.
- Belle, J., ed., 1961. *Uranium Dioxide: Properties and Nuclear Applications*, U.S. Atomic Energy Commission, Washington, D.C.
- Belle, J., et al., January 1976. *ThO₂ and ThO₂-²³³UO₂ High Density Fuel Pellet Manufacture for the Light Water Breeder Reactor (LWBR) Development Program*, WAPD-TM-1244(L), Westinghouse Bettis Atomic Power Laboratory, West Mifflin, Pennsylvania.
- Bereolos, P. J., C. W. Forsberg, D. C. Kocher, and A. M. Krichinsky, April 1998. *Strategy for Future Use and Disposition of Uranium-233: Technical Information*, ORNL/TM-13552, Oak Ridge National Laboratory, Oak Ridge, Tennessee.
- Bereolos, P. J., C. W. Forsberg, S. N. Storch, and A. M. Krichinsky, June 1998. *Strategy for the Future Use and Disposition of Uranium-233: History, Inventories, Storage Facilities, and Potential Future Uses*, ORNL/TM-13551, Lockheed Martin Energy Research Corp., Oak Ridge National Laboratory, Oak Ridge, Tennessee.
- Boeing Aerospace Company, 1981a. *Analysis of Space Systems Study for the Space Disposal of Nuclear Waste—Study Report and Executive Summary*, Vol. 1, NASA-CR-161867, Seattle, Washington.
- Boeing Aerospace Company, 1981b. *Analysis of Space Systems Study for the Space Disposal of Nuclear Waste—Study Report and Technical Report*, Vol. 2, NASA-CR-162029, Seattle, Washington.

Boeing Aerospace Company, 1982a. *Analysis of Space Systems for the Space Disposal of Nuclear Waste Follow-On Study—Executive Summary*, Vol. 1, D180-26777-1, Seattle, Washington.

Boeing Aerospace Company, 1982b. *Analysis of Space Systems for the Space Disposal of Nuclear Waste Follow-On Study—Technical Report*, Vol. 2, D180-26777-2, Seattle, Washington.

Bunn, M., November 23, 1998. *Thinking About the Spent Fuel Standard: Presentation to the NAS Panel on the Spent Fuel Standard*, National Academy of Sciences, Washington, D.C.

Cagle, G. W., June 25, 1997. Lockheed Martin Energy Systems, Inc., Y-12 Plant, Oak Ridge, Tennessee, personal communication to A. S. Icenhour, Lockheed Martin Energy Research Corp., Oak Ridge National Laboratory, Oak Ridge, Tennessee.

Chellew, N. R. and G. A. Bennett, 1961. “The Melt Refining of Irradiated Uranium: Application to EBR-II Fast Reactor Fuel XII, The Behavior of Rhenium, Molybdenum, Palladium, Rhodium, Technetium, Antimony, Cadmium, and Tellurium,” *Nuc. Sci. and Eng.*, **9**:87–90.

Chellew, N. R., G. A. Bennett, and V. G. Trice, 1961. “The Melt Refining of Irradiated Uranium: Application to EBR-II Fast Reactor Fuel VIII, The Behavior of Rare Earths, Yttrium, Barium, Strontium, and Cesium,” *Nuc. Sci. and Eng.*, **9**:64–70.

Cochran, J. R., September 22, 1997. Sandia National Laboratory, Albuquerque, New Mexico, personal communication to A. S. Icenhour, Oak Ridge National Laboratory, Oak Ridge, Tennessee.

Cohen, B., 1980. “Ocean Dumping of High-Level Waste—An Acceptable Solution That We Can ‘Guarantee,’” *Nucl. Technol.* **47**, 163.

Coopersmith, Jonathan, August 1992. “Disposal of High-Level Nuclear Waste in Space,” IAA-92-0222, 43rd Congress of the International Astronautical Federation, August 28–September 5, 1992, Washington, D.C.

Cosman, Bard C., January 1985. *Space Disposal of Radioactive Wastes: A Literature Review and Bibliography*, American Institute of Aeronautics and Astronautics, Technical Information Service, New York, New York.

Cox, S., July 1995. *Criteria for the Safe Storage of Enriched Uranium at the Y-12 Plant*, Y/ES-015, Oak Ridge Y-12 Plant, Martin Marietta Energy Systems, Inc., Oak Ridge National Laboratory, Oak Ridge, Tennessee.

Dalle Donne, M., S. Dorner, and G. Schumacher, July 1978. “Development Work for a Borax Internal Core-Catcher for Gas-Cooled Fast Reactor,” *Nucl. Technol.*, **39**, 138–154.

Defense Nuclear Facilities Safety Board, May 26, 1994. *Recommendation 94-1 to the Secretary of Energy*, Washington, D.C.

Defense Nuclear Facilities Safety Board, March 3, 1997. *Recommendation 97-1 to the Secretary of Energy*, Washington, D.C.

Duerksen, W. K., May 19, 1997. Lockheed Martin Energy Systems, Y-12 Plant, Oak Ridge, Tennessee, personal communication to A. S. Icenhour, Lockheed Martin Energy Research Corp., Oak Ridge National Laboratory, Oak Ridge, Tennessee.

Duguid, J., V. Vallikat, J. McNeish, D. Cresap, and H. Loo, September 10, 1998. "Performance Assessment of DOE Spent Nuclear Fuel and Surplus Plutonium," pp. 401–407 in *Proc. Third Topical Meeting on DOE Spent Nuclear Fuel and Fissile Materials Management, Charleston, South Carolina, September 8–11, 1998*, American Nuclear Society, La Grange Park, Illinois.

Ebbinghaus, B. B., C. Cicero-Herman, L. Gray, and H. Shaw, February 1999. *Plutonium Immobilization Project Baseline Formulation*, UCRL-ID-133089, Lawrence Livermore National Laboratory, Livermore, California.

Elam, K. R., C. W. Forsberg, C. M. Hopper, and R. Q. Wright, November 1997. *Isotopic Dilution Requirements for ^{233}U Criticality Safety in Processing and Disposal*, ORNL/TM/13524, Lockheed Martin Energy Research Corp., Oak Ridge National Laboratory, Oak Ridge, Tennessee.

Feinendegen, L. E. and J. J. McClure (editors), May 30–31, 1996. *Workshop: Alpha-Emitters for Medical Therapy, Denver, Colorado*, DOE/NE-0113, U. S. Department of Energy, Germantown, Maryland.

Forsberg, C. W., January 1993. "An Ocean Island Geological Repository—A Second-Generation Option for Disposal of Spent Fuel and High-Level Waste," *Nucl. Technol.*, **101**, 40–53.

Forsberg, C. W., G. W. Parker, J. C. Rudolph, I. W. Osborne-Lee, and M. A. Kenton, June 1–4, 1997. "COMSORS: A Light-Water-Reactor Chemical Core Catcher," *2nd International Topical Meeting on Advanced Reactor Safety, Orlando, Florida*, American Nuclear Society, La Grange Park, Illinois.

Forsberg, C. W., October 31, 1997. *Trip Report: Disposition of Excess ^{233}U , Savannah River Site Visit, October 14, 1997*, Lockheed Martin Energy Research Corp., Oak Ridge National Laboratory, Oak Ridge, Tennessee.

Forsberg, C. W. and A. M. Krichinsky, January 1998. *Strategy for the Future Use and Disposition of Uranium-233: Overview*, ORNL/TM-13550, Lockheed Martin Energy Research Corp., Oak Ridge National Laboratory, Oak Ridge, Tennessee.

Forsberg, C. W., C. M. Hopper, J. L. Richter, and H. C. Vantine, March 1998. *Definition of Weapons-Usable Uranium-233*, ORNL/TM-13517, Lockheed Martin Energy Research Corp., Oak Ridge National Laboratory, Oak Ridge, Tennessee.

Forsberg, C. W., S. N. Storch, and L. C. Lewis, July 7, 1998. *Uranium-233 Waste Definition: Disposal Options, Safeguards, Criticality Control, and Arms Control*, ORNL/TM-13591, Oak Ridge National Laboratory, Oak Ridge, Tennessee.

Frankhauser, W. L., et al., February 1967. *Fabrication of Fuel Rods Containing U-233 Pelletized Oxide Fuels*, WAPD-TM-588, Westinghouse Bettis Atomic Power Laboratory, West Mifflin, Pennsylvania.

Friedlander, A. L., et al., 1991. "Disposal Methods," pp. 445–456 in *Nuclear Thermal Propulsion: A Joint NASA/DOE/DOD Workshop in Cleveland, Ohio, July 10–12, 1990*, NASA-CP-10079, CONF-9007234, Science Applications International Corporation, La Jolla, California.

Geerlings, M. W., R. van der Hout, F. M. Kaspersen, and C. Apostolides, 1993. "The Feasibility of ^{225}Ac as a Source of Alpha-Particles in Radioimmunotherapy," *Nucl. Med. Commun.*, **14**(2), 121.

Gillins, R. L. and S. D. Poling, May 10, 1994. "Plasma Hearth Waste Treatment Demonstration for Radioactive Mixed Waste," *Proc. 1994 Incineration Conference*, Houston, Texas.

Ginanni, J. M., September 22, 1997. U.S. Department of Energy, Nevada Operations Office, Las Vegas, Nevada, personal communication to A. S. Icenhour, Oak Ridge National Laboratory, Oak Ridge, Tennessee.

Gray, W. J., September 11, 1998. "Corrosion of Aluminum-Based Spent Nuclear Fuel Under Geological Disposal Conditions," pp. 697–698 in *Proc. Third Topical Meeting on DOE Spent Nuclear Fuel and Fissile Materials Management, Charleston, South Carolina, September 8–11, 1998*, American Nuclear Society, La Grange Park, Illinois.

Hall, J. C., July 22, 1998. Letter to H. R. Canter et al., *Commercial Reuse of DP Excess Material Stored at ORNL*, Oak Ridge Operations Office, U. S. Department of Energy, Oak Ridge, Tennessee.

Halsey, W. G., August 6, 1998. Lawrence Livermore National Laboratory, Livermore, California, personal communication to Stephen N. Storch, Oak Ridge National Laboratory, Oak Ridge, Tennessee.

Hanson, B. D., July 1998. "The Burnup Dependence of Light-Water Reactor Spent Fuel Oxidation," PNNL-11929, Pacific Northwest National Laboratory, Richland, Washington.

Harmon, R., C. V. Smith, and R. Henry, 1998. "Dry Milling and Blending of High-Enriched Uranium Trioxide," pp. 304–309 in *Proc. Third Topical Meeting on DOE Spent Nuclear Fuel and Fissile Material Management, September 8–11, 1998, Charleston, South Carolina*, American Nuclear Society, La Grange Park, Illinois.

Hassel, G. R., R. M. Geimer, J. A. Batdorf, and G. L. Leatherman, May 10, 1994. "Evaluation of the Plasma Hearth Process for Mixed Waste Treatment Applications," *Proc. 1994 Incineration Conference*, Houston, Texas.

Hodges, M. E. and M. L. Hyder, September 9, 1998. "Off-gas Studies for the Melt-Dilute Program," pp. 40–43 in *Proc. Third Topical Meeting on DOE Spent Nuclear Fuel and Fissile Materials Management, Charleston, South Carolina, September 8–11, 1998*, American Nuclear Society, La Grange Park, Illinois.

Howell, J. P. and J. F. Zino, September 9, 1998. "Fission Product Release from Spent Nuclear Fuel During Melting," pp. 31–39 in *Proc. Third Topical Meeting on DOE Spent Nuclear Fuel and Fissile Materials Management, Charleston, South Carolina, September 8–11, 1998*, American Nuclear Society, La Grange Park, Illinois.

Huizenga, D. G., August 17, 1998. *DOE Memorandum to Henry F. Dalton, Assistant Manager for Material Stabilization, Rocky Flats Field Office*, U. S. Department of Energy, Washington, D.C.

Hyland, R. E., 1970. "Evaluation of Criticality Mass for Open-Cycle, Gas-Core Rocket Reactor," *Am. Nucl. Soc. Trans.*, **13**(1), 15.

International Advisory Committee, 1998. *The Radiological Situation at the Atolls of Mururoa and Fangataufa*, International Atomic Energy Agency, Vienna, Austria.

International Atomic Energy Agency, August 1993. *The Physical Protection of Nuclear Materials*, INFCIRC/225/Rev. 3, Vienna, Austria.

Knapp, Jr., F. F. and S. Mirzadeh, 1994. "The Continuing Important Role of Radionuclide Generator Systems for Nuclear Medicine," *Eur. J. Nucl. Med.*, **21**(10), 1151.

Krupa, J. F., September 9, 1998. "Spent Nuclear Fuel Alternative Cost Update," pp. 44–47 in *Proc. Third Topical Meeting on DOE Spent Nuclear Fuel and Fissile Materials Management, Charleston, South Carolina, September 8–11, 1998*, American Nuclear Society, La Grange Park, Illinois.

Laidler, J., March 5, 1999. *Telephone conversation between J. Laidler (Argonne National Laboratory) and L. Lewis (Idaho National Engineering and Environmental Laboratory)*, Idaho Falls, Idaho.

Lam, P., R. L. Sindelar, and H. B. Peacock, Jr., September 10, 1998. "Vapor Corrosion of Aluminum Cladding Alloys," pp. 536–540 in *Proc. Third Topical Meeting on DOE Spent Nuclear Fuel and Fissile Materials Management, Charleston, South Carolina, September 8–11, 1998*, American Nuclear Society, La Grange Park, Illinois.

Lantz, E. and W. Mayo, 1972. "A Small 1400°K Reactor for Brayton Space Power Systems," *Am. Nucl. Soc. Trans.*, **15**(1), 4, American Nuclear Society, La Grange Park, Illinois.

Leitnaker, J. M., M. L. Smith, and C. M. Fitzpatrick, April 1972. *Conversion of Uranium Nitrate to Ceramic-Grade Oxide for the Light Water Breeder Reactor: Process Development*, ORNL-4755, Oak Ridge National Laboratory, Oak Ridge, Tennessee.

Louthan, Jr., M. R., B. J. Wiersma, and J. I. Mickalonis, September 10, 1998. "Development of Test Protocols For Geologic Disposal of Aluminum Based Spent Nuclear Fuel," pp. 525–529 in *Proc. Third Topical Meeting on DOE Spent Nuclear Fuel and Fissile Materials Management, Charleston, South Carolina, September 8–11, 1998*, American Nuclear Society, La Grange Park, Illinois.

Ludwig, H., et al., 1989. *Small Propulsion Reactor Design Based on Particle Bed Reactor Concept*, BNL-41450, Brookhaven National Laboratory, Upton, New York.

McCallum, E. W., May 15, 1998. *DOE Memorandum for David G. Huizenga, Deputy Assistant Secretary, Nuclear Material and Facility Stabilization, Office of Environmental Management*, U. S. Department of Energy, Washington, D.C.

McCallum, R. F. et al., January 1983. *Waste-Mixes Study for Space Disposal*, ONWI-422, Pacific Northwest National Laboratory, Richland, Washington.

McEachern, R. J. and P. Taylor, 1998. "A Review of the Oxidation of Uranium Dioxide at Temperatures Below 400°C," *J. Nucl. Mater.*, **254**, 87–121.

McWhorter, D. L., 1995. *HEU Downblending Program, Savannah River Site Capabilities Report*, NMP-PLS-950357, Revision 0, Westinghouse Savannah River Company, Savannah River Site, Aiken, South Carolina.

McWhorter, D. L., April 15, 1997. Westinghouse Savannah River Company, Savannah River Site, Aiken, South Carolina, personal communication to A. S. Icenhour, Lockheed Martin Energy Research Corp., Oak Ridge National Laboratory, Oak Ridge, Tennessee.

McWhorter, D. L., April 29, 1997. Westinghouse Savannah River Company, Savannah River Site, Aiken, South Carolina, personal communication to A. S. Icenhour, Lockheed Martin Energy Research Corp., Oak Ridge National Laboratory, Oak Ridge, Tennessee.

MacFarlane, D., 1963. *A 200-watt Conduction-Cooled Reactor Power Supply for Space Application*, ANL-6694, Argonne National Laboratory.

Mangeno, J. J. and C. W. Burrows, March 1995. *Occupational Radiation Exposure from Naval Reactors' Department of Energy Facilities*, NT-95-3, U. S. Department of Energy, Naval Nuclear Propulsion Program, Office of Naval Reactors, Washington, D.C.

National Research Council, 1998. *Electrometallurgical Techniques for DOE Spent Nuclear Fuel Treatment: Spring 1998 Status Report on Argonne National Laboratory's R&D Activity*, National Academy Press, Washington, D.C.

Nuclear Fuel, February 10, 1997. "DOE, TVA Sign Off-Spec. HEU Memo," McGraw-Hill, New York, pp. 16–17.

Nuclear Waste Policy Act, 1982. *Nuclear Waste Policy Act*, Pub. L. 97–425.

Nuclear Waste Policy Amendments Act, 1987. *Nuclear Waste Policy Amendments Act*, Pub. L. 100–203.

Oak Ridge National Laboratory, February 18, 1994. *ORNL Nuclear Criticality Safety Program Procedures NCS-1.0, Rev 0, Appendix A: Control Limits on Fissionable Nuclides at ORNL*, Oak Ridge, Tennessee.

Oak Ridge National Laboratory, July 13, 1995. *Storage and Disposition of Weapons-Usable U-233 by Aqueous Nitrate Blending with Natural or Depleted Uranium to 2% Enrichment in the Radiochemical Development Facility at the Oak Ridge National Laboratory*, ORNL/MD/LTR-25, Rev 0, Lockheed Martin Energy Systems, Oak Ridge National Laboratory, Oak Ridge, Tennessee.

Oak Ridge National Laboratory, July 19, 1995a. *Storage and Disposition of Weapons-Usable U-233 by Dry Powder Blending with Natural or Depleted Uranium to 2% enrichment in the Radiochemical Development Facility at the Oak Ridge National Laboratory, Predecisional Draft*. ORNL/MD/LTR-29, Rev. 0, Lockheed Martin Energy Systems, Oak Ridge National Laboratory, Oak Ridge, Tennessee.

Oak Ridge National Laboratory, July 27, 1995. *Storage and Disposition of Weapons-Usable U-233 by Dry Melt Blending with Natural or Depleted Uranium in the Radiochemical Development Facility (Building 3019 Complex) at the Oak Ridge National Laboratory (ORNL)*, ORNL/MD/LTR-24, Rev. 1, Lockheed Martin Energy Systems, Oak Ridge National Laboratory, Oak Ridge, Tennessee.

Olander, D. L., 1976. *Fundamental Aspects of Nuclear Fuel Elements*, TID-26711-P1, Energy Research and Development Administration, Technical Information Center, U.S. Department of Commerce, Springfield, Virginia.

Organization for Economic Co-operation and Development, Nuclear Energy Agency, 1988. *Feasibility of Disposal of High-Level Radioactive Waste into the Seabed*, OECD Publications Service, Paris, France.

Paperiello, Carl J., Director, Office of Nuclear Material Safety and Safeguards, January 25, 1999. *Letter to Lake H. Barrett, Acting Director, Office of Civilian Radioactive Waste Management, U.S. Department of Energy, Subject: U.S. Department of Energy Plans for Disposal of Surplus Weapons Plutonium*, U.S. Nuclear Regulatory Commission, Washington, D.C.

Peacock, H. B., Jr., T. M. Adams, and N. C. Iyer, September 9, 1998. "Development of the Melt-Dilute Treatment Technology for Aluminum-Based DOE Spent Nuclear Fuel," pp. 18–22 in *Proc. Third Topical Meeting on DOE Spent Nuclear Fuel and Fissile Materials Management*, Charleston, South Carolina, September 8–11, 1998, American Nuclear Society, La Grange Park, Illinois.

Poling, S. D., et al., March 9, 1994. *Conceptual Design Report for the Plasma Hearth Process (PHP) Bench-Scale Radioactive System*, SAIC-94/1003, Scientific Applications International Corporation, Idaho Falls, Idaho.

Rice, E. E. and C. C. Priest, 1981. "An Overview of Nuclear Waste Disposal in Space," pp. 370–386 in *The Technology of High-Level Nuclear Waste Disposal—Advances in the Science and Engineering of the Management of High-Level Nuclear Waste*, Vol. 1, DOE/TIC-4621, U. S. Department of Energy, Technical Information Center, Oak Ridge, Tennessee.

Rice, E. E., R. S. Denning, and A. L. Friedlander, February 1982. *Preliminary Risk Assessment for Nuclear Waste Disposal in Space*, Vol. 2, Technical Report, NASA/CR-162029, Battelle Columbus Laboratories, Columbus, Ohio.

Royal Commission on Environmental Pollution, September 1976. *Sixth Report, Nuclear Power and the Environmental Pollution*, Her Majesty's Stationery Office, London.

Savannah River Site, April 1997. *Alternative Aluminum Spent Nuclear Fuel Treatment Technology Development Status Report*, WSRC-TR-97-0084, Westinghouse Savannah River Company, Aiken, South Carolina.

Shott, G. J. et al., June 1995. *Performance Assessment for the Area 5 Radioactive Waste Management Site at the Nevada Test Site, Nye County, Nevada*, DOE/NV/11432-196, U. S. Department of Energy, Nevada Operations Office, Las Vegas, Nevada.

SNF Task Team, March 1997. *Technical Strategy for Managing of INEEL Spent Nuclear Fuel*, Idaho National Engineering and Environmental Laboratory, Idaho Falls, Idaho.

Toran, L. E., et al., June 1997. *The Potential for Criticality Following Disposal of Uranium at Low-Level Waste Facilities*, NUREG/CR-6505, U.S. Nuclear Regulatory Commission, Washington, D.C.

U.S. Congress, October 30, 1992, *Waste Isolation Pilot Plant Land Withdrawal Act*, Public Law 102-579, Washington, D.C.

U.S. Congress, 1996. *Waste Isolation Pilot Plant Land Withdrawal Act, Public Law 102-579*, as amended.

U.S. Department of Energy, July 1992. *Characteristics of Potential Repository Wastes*, DOE/RW-0184-R1, Vol. 2, Washington, D.C.

U.S. Department of Energy, August 30, 1994. *Waste Form Requirements for the Potential Disposition of Weapons-Usable Fissile Materials in a Deep Geological Repository*, A00000000-00811-1708-00004, Rev. 00C, Washington, D.C.

U.S. Department of Energy, March 29, 1995. *Summary Report of the Screening Process*, DOE/MD-0002, Washington, D.C.

U.S. Department of Energy, October 1995. *Final Environmental Impact Statement: Interim Management of Nuclear Materials*, DOE/EIS-0220, U. S. Department of Energy, Savannah River Site, Aiken, South Carolina.

U.S. Department of Energy, December 12, 1995. *Record of Decision, Notice of Narrowing of Alternatives, and Notice of Preferred Alternatives*, U. S. Department of Energy, Savannah River Operations Office, Aiken, South Carolina.

U.S. Department of Energy, February 8, 1996, *Record of Decision: Materials Stabilization*, U.S. Department of Energy, Savannah River Operations Office, Aiken, South Carolina.

U.S. Department of Energy, April 1996. *Waste Acceptance Criteria for the Waste Isolation Pilot Plant*, DOE/WIPP-069, Rev. 5, Carlsbad, New Mexico.

U.S. Department of Energy, Office of Fissile Materials Disposition, June 1996a. *Disposition of Surplus Highly-Enriched Uranium Final Environmental Impact Statement*, DOE/EIS-0240, Washington, D.C.

U.S. Department of Energy, June 1996b. *Technical Strategy for the Treatment, Packaging, and Disposal of Aluminum-Based Spent Nuclear Fuel*, Washington, D.C.

U.S. Department of Energy, July 29, 1996. *Record of Decision for the Disposition of Surplus Highly-Enriched Uranium Final Environmental Impact Statement*, Washington, D.C.

U.S. Department of Energy, Nevada Operations Office, September 1996. *Nevada Test Site Waste Acceptance Criteria—Revision O*, NVO-325, Rev. 2, Las Vegas, Nevada.

U.S. Department of Energy, January 1997. *Final Nonproliferation and Arms Control Assessment of Weapons-Usable Fissile Material Storage and Excess Plutonium Disposition Alternatives*, DOE/NN-0007, DOE Office of Arms Control and Nonproliferation, Washington, D.C.

U.S. Department of Energy, Carlsbad Area Office, September 1997. *Waste Isolation Pilot Plant Disposal Phase Final Supplemental Environmental Impact Statement*, DOE/EIS-0026-S-2, Carlsbad, New Mexico.

U.S. Department of Energy, September 25, 1997. *Implementation Plan for Defense Nuclear Facilities Safety Board Recommendation 97-1: Safe Storage of Uranium-233*, U. S. Department of Energy, Washington, D.C.

U.S. Department of Energy, Idaho Operations Office, November 1997. *Plutonium Focus Area Technical Advisory Panel Recommendation: The United States Should Adopt a Single Policy for the Safeguards Termination Limits on Fissile Materials*, DOE/ID-10611, Idaho Falls, Idaho.

U.S. Department of Energy, December 1997. *Integrated Data Base Report—1996: U. S. Spent Nuclear Fuel and Radioactive Waste Inventories, Projections, and Characteristics*, DOE/RW-0006, Rev 13, Washington, D.C.

U.S. Department of Energy, August 1998. *Final Environmental Impact Statement on Management of Certain Plutonium Residues and Scrub Alloy Stored at the Rocky Flats Environmental Technology Center*, DOE/EIS-0277E, Washington, D.C.

U.S. Department of Energy, December 1998a. *Report on the Savannah River Site Aluminum-Based Spent Nuclear Fuel Alternatives Case Study*, Savannah River Operations Office, Aiken, S.C.

U.S. Department of Energy Office of Arms Control and Nonproliferation, December 1998b. *Nonproliferation Impacts Assessment for the Management of the Savannah River Site Aluminum-Based Spent Nuclear Fuel*, Washington, D.C.

U.S. Department of Energy, December 1998c. *Savannah River Site Spent Nuclear Fuel Management Draft Environmental Impact Statement*, DOE/EIS-0279D, Washington, D.C.

U.S. Department of Energy, December 1998d. *Proposed: DOE Standard: Criteria for Packaging and Storing Uranium-233-Bearing Materials*, DOE-STD-3025-98, Washington, D.C.

U.S. Department of Energy, Office of Fissile Material Disposition, December 1998e. *Acceptance Criteria for Plutonium-Bearing Materials to be Dispositioned by Immobilization*, DOE/MD-0011, Rev. 0, Washington, D.C.

U.S. Department of Energy Office of Fissile Materials Management, 1999. *Summary Report of the Screening Process to Determine Reasonable Alternatives for Disposition of Uranium-233*, DOE/MD-0012, Washington, D.C.

U.S. Department of Energy, Office of Environmental Management, January 1999. *Advanced Mixed Waste Treatment Project Final Environmental Impact Statement*, DOE/EIS-0290, Idaho Operations Office, Idaho Falls, Idaho.

U.S. Department of Energy, Assistant Secretary for Environmental Affairs, February 11, 1999. *Second Record of Decision on Management of Certain Plutonium Residues and Scrub Alloy Stored at the Rocky Flats Environmental Technology Site*, Washington, D.C.

U.S. National Academy of Sciences, December 1983. *A Study of the Isolation System for Geologic Disposal of Radioactive Wastes*, National Academy Press, Washington, D.C., p. 12.

U.S. Nuclear Regulatory Commission, June 1997. *The Potential for Criticality Following Disposal of Uranium at Low-Level Waste Facilities*, NUREG/CR-6505, Vol. 1, Washington, D.C.

U.S. Nuclear Waste Technical Review Board, 1996. *Report to the U.S. Congress and the Secretary of Energy: 1995 Findings and Recommendations*, Arlington, Virginia.

Voorheis, G. M., April 2, 1998. "Letter to K. A. Klein, Deputy Manager for Technical Programs, U.S. Department of Energy, Rocky Flats Field Office," 98-RF-01743, Rocky Flats Environmental Technology Site, Rocky Flats, Colorado.

Weinberg, A., M. Alanso, and J. N. Barkenbus, Eds., 1985. *The Nuclear Connection: A Reassessment of Nuclear Power and Nuclear Proliferation*, Paragon House Publishers, New York.

Wiersma, B. J., J. I. Mickalonis, and J. R. Louthan, Jr., September 10, 1998. "Evaluation of Test Methodologies for Dissolution and Corrosion of Al-SNF," pp. 516–524 in *Proc. Third Topical Meeting on DOE Spent Nuclear Fuel and Fissile Materials Management, Charleston, South Carolina, September 8–11, 1998*, American Nuclear Society, La Grange Park, Illinois.

Wijesinghe, A. M., et al., August 23, 1996. *Alternative Technical Summary Report for Immobilized Disposition in Deep Boreholes*, UCRL-LR-121736, Lawrence Livermore National Laboratory, Livermore, California.

Wijesinghe, A. M., August 6, 1998. Lawrence Livermore National Laboratory, Livermore, California, "Re: Request for Borehole Evaluation Report," correspondence to Stephen N. Storch, Oak Ridge National Laboratory, Oak Ridge, Tennessee.

Appendix A
RADIATION LEVELS FROM ²³³U

The radiation levels from ^{233}U determine (1) many of the facility requirements for its processing, (2) its transport requirements, and (3) the waste-handling requirements of any ^{233}U product. For example, if the ^{233}U is classified as TRUW, it may be either CH or RH waste depending upon the external radiation levels. For TRUW and most other wastes, the dividing line between CH and RH is 200 mrem/h at the surface of the container. The radiation levels from ^{233}U , as discussed in Sect. 2, depend upon (1) the impurities in ^{233}U , particularly ^{232}U and its decay products; (2) the age of the ^{233}U since the gamma-emitting decay products have been removed from the ^{233}U and ^{232}U impurity; and (3) other materials that the ^{233}U is mixed with. This appendix provides some additional information on expected radiation levels.

A set of calculations was made to determine the radiation dose from a 55-gal (208-L) drum near the surface of the drum. Radiation doses were calculated 1 cm from the drum as an approximation for surface measurements on the drum (minimize numerical instabilities in radiation calculations). The following assumptions were used.

- *Uranium-233 impurity level.* The ^{233}U was assumed to have 100 ppm ^{232}U . The ^{233}U inventory has materials with ^{232}U concentrations from a few ppm to somewhat >100 ppm.
- *Uranium-232 age.* The primary radiation from ^{233}U in storage is from the ^{232}U decay product, ^{208}Tl . This decay product emits a 2.6-MeV gamma ray. If the uranium has been purified, the ^{208}Tl builds up over time and then decays as the ^{232}U decays. The time of maximum radiation levels is 10.3 years after separation of the decay products from the uranium. The radiation calculations herein are for this particular time of maximum radiation.
- *Drum characteristics.* The drum height is 35 in., the diameter is 24 in., and the wall thickness is 1/16-in. carbon steel.
- *Uranium chemical form.* The uranium is assumed to be U_3O_8 in the form of a loose powder with a density of 1.5 g/cm^3 . The drum contains ~ 390 kg of oxide.

If the ^{233}U is isotopically diluted with DU to become non-weapons-usable ^{233}U (1 part ^{233}U with 7.407 parts DU containing 0.2 wt % ^{235}U), the external radiation doses calculated 1 cm from the drum will be 141 R/h. The ^{232}U concentration would have to be <0.1 ppm to be CH material (<200 mrem/h). In this specific example, a neutron absorber would have to be added to the drum for criticality control.

If the ^{233}U is isotopically diluted with DU to minimize criticality concerns (1 part ^{233}U with 188 parts DU containing 0.2 wt % ^{235}U), the external radiation doses calculated 1 cm from the drum will be 6.247 R/h. The ^{232}U concentration would have to be reduced to <3 ppm to reduce the radiation levels to those of CH waste (<200 mrem/h). This implies that a CH drum (without special features) can contain up to a few tens of grams of ^{233}U with high concentrations of ^{232}U (>100 ppm ^{232}U) or a few hundred grams of ^{233}U with lower ^{232}U concentrations (105 ppm ^{232}U).

Appendix B

RECOVERY OF ^{229}Th FROM ^{233}U FOR MEDICAL USE

B.1 MEDICAL USES OF BISMUTH-213

One potential large-scale use of ^{233}U involves one of its decay products, ^{213}Bi (Bereolos et al. June 1998). Over the past decade, there has been considerable research in the area of radioimmunotherapy using alpha receptors. Specifically of interest are antitumor antibodies radiolabeled with an alpha emitter (Knapp and Mirzadeh 1994; Geerlings 1993). In this method, the isotopes are attached to antibodies that specifically target the cancer cell, after which the resulting alpha emissions kill these cells with high efficiency.

Previous work in this area focused on using ^{212}Bi , which is produced by the decay chain of ^{232}U (or ^{228}Th). However, the undesirable side effect of ^{212}Bi is the 2.6-MeV gamma radiation emitted during the decay of ^{208}Tl . The radiation level from this decay could prove to be a debilitating hazard to the patient and an unacceptable risk to the patient's family members and the medical staff involved in the treatment. There are also particular concerns about the long-term dose levels to medical personnel who treat multiple patients.

A potential solution to this dilemma is the use of ^{213}Bi produced from the decay chain of ^{233}U (Pippen 1995). Bismuth-213 has the unique properties of being primarily an alpha emitter (by way of ^{213}Po) and having only a 2% probability of decaying to ^{209}Tl , which emits a 1.5-MeV gamma-ray. This compares with 36% probability for ^{212}Bi to decay to ^{208}Tl , which emits a 2.6-MeV gamma ray. Still, it is chemically identical to ^{213}Bi , with a similar half-life.

B.2 BISMUTH RECOVERY PROCESS

Recovery of ^{213}Bi involves a three-step process, as shown in Fig. B.1.

- *Recovery of ^{229}Th from ^{233}U .* The ^{233}U is dissolved in acid, and ^{229}Th and its decay product are separated from the uranium by ion exchange in a shielded process facility with appropriate safeguards. The resulting thorium-bearing solution contains essentially no fissile uranium; has no nuclear weapons use; and, therefore, poses no complications in terms of safeguards or nuclear critically.
- *Recovery of ^{225}Ac from ^{229}Th .* The ^{225}Ac is separated from ^{229}Th and the other decay products. This chemical separation is done in a shielded process facility. No safeguards are required because there is no fissile material. Because actinium is not a part of the decay chain of ^{232}U , this separation removes the undesirable product, ^{208}Tl , and its precursors. The ^{225}Ac is packaged in a biomedical generator system and is sent to the hospital.
- *Recovery of the ^{213}Bi product.* At the hospital, the ^{213}Bi is recovered from the ^{225}Ac , converted into the appropriate chemical form, and injected into the patient. The ^{213}Bi has a short half-life (45.6 minutes). The transport times are too long for separation of the ^{213}Bi at a central site; therefore, the final separations and chemical processing are done at the hospital.

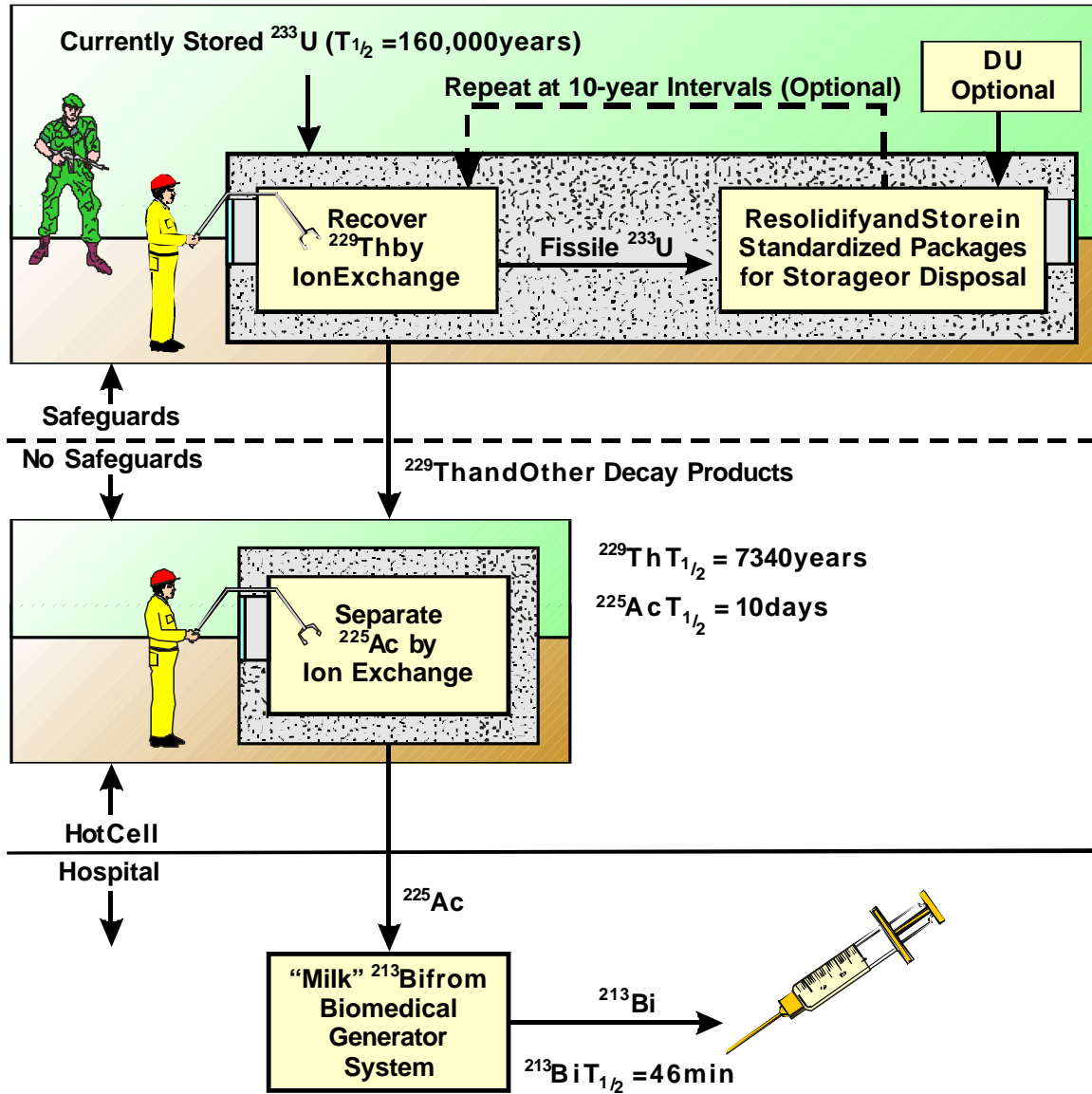

Fig.B.1. Flowsheet for ^{213}Bi production for treatment of cancer.

Currently, ^{229}Th produced from the decay of ^{233}U is the only source of ^{213}Bi . Additionally, ^{229}Th could be produced by irradiation of ^{226}Ra in a nuclear reactor (Feinendegen and McClure 1996). This alternative production route would allow added production of ^{213}Bi ; however, the levels of the contaminant, ^{228}Th , produced by irradiation of radium, are much higher than those from decay of $^{233}\text{U}/^{232}\text{U}$ mixtures in inventory.

B.3 RECOVERY OF THORIUM-229 FROM URANIUM-233

After 30 years of storage, 1 kg of ^{233}U will contain ~20 mg of ^{229}Th . The ^{233}U currently stored at ORNL contains ~40 g of ^{229}Th (Feinendegen and McClure 1996). Thorium-229 can be recovered from the uranium as a separate process or as a step in an isotopic dilution process using the aqueous nitrate blend method. Recovery of the ^{229}Th involves dissolving the uranium in nitric acid and passing the solution through an ion-exchange column to remove the thorium. After the recovery step, the ^{233}U nitrate solution could be either converted back to oxide and stored in standardized packages for future use or disposal or diluted with DU solution prior to conversion to oxide. The entire process may be repeated after several years for in-growth of ^{229}Th and other decay products. It is likely that the isotopic dilution of the ^{233}U would have little effect on this application. The decay chain of ^{238}U , which would be used as the blend-down material, does not contain actinium. Therefore, the third separation step in the recovery of ^{213}Bi would still isolate the desired part of the ^{233}U decay chain.

Separation of ^{229}Th from ^{233}U has been successfully demonstrated on a small scale using an anion ion-exchange resin. The separation is accomplished by first dissolving the ^{233}U in nitric acid to give a concentration of 200 to 400 g U/L in 8 to 9 M nitric acid solution. The solution is then passed through an anion ion-exchange resin, during which time the thorium and a portion of the uranium collect on the resin. The uranium is washed from the resin with a volume of 8 M nitric acid, which is about equal to the volume of solution processed. The ^{229}Th is then recovered by washing the ion-exchange resin with 0.1 M nitric acid. Further processing would be required to prepare the ^{229}Th for medical use as previously described. Uranium solution from the thorium removal process is in a form suitable for isotopic dilution by the aqueous nitrate blending process (ORNL 1995) and/or conversion to oxide for storage or disposal as previously described. The process will work on ^{233}U -containing neutron absorbers such as cadmium and gadolinium.

B.4. REFERENCES FOR APPENDIX B

Bereolos, P. J., L. C. Lewis, C. W. Forsberg, S. N. Storch, and A. M. Krichinsky, June 1998. *Draft: Strategy for Future Use and Disposition of Uranium-233: History, Inventories, Storage Facilities, and Potential Future Uses*, ORNL/TM-13551, Lockheed Martin Energy Research Corp., Oak Ridge National Laboratory, Oak Ridge, Tennessee.

Fienendegen, L. E. and J. J. McClure (eds.), May 1996. *Workshop: Alpha-Emitters for Medical Therapy, Denver, Colorado, May 30–31, 1996*, DOE/NE-0113, U.S. Department of Energy, Germantown, Maryland.

Knapp, Jr., F. F. and S. Mirzadeh, 1994. "The Continuing Important Role of Radionuclide Generator Systems for Nuclear Medicine," *Eur. J. Nucl. Med.*, **21**(10), 1151.

Geerlings, M. W., R. van der Hoot, F. M. Kaspersen, and C. Apostolides, 1993. "The Feasibility of ^{225}Ac as a Source of Alpha-Particles in Radioimmunotherapy," *Nuclear Medical Communications*, **14**(2):121.

Oak Ridge National Laboratory, July 13, 1995. *Storage and Disposition of Weapons-Usable U-233 by Aqueous Nitrate Blending with Natural or Depleted Uranium to 2% Enrichment in the Radiochemical Development Facility at the Oak Ridge National Laboratory*, ORNL/MD/LTR-25, Rev. 0, Lockheed Martin Energy Systems, Oak Ridge National Laboratory, Oak Ridge, Tennessee.

Pippen, C. G., et al., 1995. "Recovery of ^{213}Bi from an ^{225}Ac Cow: Application to the Radiolabeling of Monoclonal Antibodies with Alpha-Emitter ^{213}Bi ," *Proc. 206th Am. Chem. Soc. Mtg.*, August 22–27, 1993, Chicago, Illinois, American Chemical Society, Washington, D.C.

Appendix C

RECOVERY OF URANIUM FROM CEUSP CANS

C.1. INTRODUCTION

Approximately one-half the inventory of ^{233}U is stored in CEUSP cans, including the single largest batch of ^{233}U and another batch of ^{233}U . This storage can is unique among packages used for fissile material storage. Most fissile materials are stored as loose solids in cans. The uranium in CEUSP cans is stored as a solid, monolithic U_3O_8 integral with the can. The can may be cut open, but the uranium will not fall out. As such, it is an excellent storage form. However, special methods are required for removal from the can, and most of the disposition options require such removal. Aqueous dissolution removal of ^{233}U from CEUSP cans is described herein. It is the only demonstrated technology for emptying these cans.

C.2 FILLING OF CEUSP CANS

The CEUSP cans are part of a process developed and used at ORNL to convert liquid solutions of ^{233}U nitrates into monolithic solids for storage. The uranium nitrate solutions contained uranium, gadolinium, and cadmium nitrates. The gadolinium and cadmium were used as neutron absorbers in the liquid solutions to prevent nuclear criticality in storage. In the solidification process, a stainless steel CEUSP can is placed in a vertical tube furnace at $\sim 800^\circ\text{C}$. The uranium nitrate solution is slowly added to the can. In the can, the solution evaporates to dryness, the nitrates decompose to oxides, and a monolithic solid product integral with the can is produced. The uranium product is U_3O_8 . After solidification, a lid is welded onto the can to provide a sealed storage can. The can is a relatively robust form of storage, and many of its design characteristics are dictated by the need for the can to withstand high-temperature processing operations. Figure C.1 shows a full CEUSP can.

C.3 REMOVAL OF URANIUM FROM CEUSP CANS

A method has been demonstrated by which the U_3O_8 , CdO , and Gd_2O_3 monoliths contained in the CEUSP cans can be removed by dissolution with nitric acid in the product can. The removal method was originally used to (1) dissolve and recycle uranium solutions during development of the CEUSP process and (2) recycle CEUSP cans during development of the CEUSP process.

The CEUSP material is contained in stainless steel cans (3-in.-diam by 24-in.-high with an internal volume of about 3 L). Each can contains ~ 4.1 kg of oxide with an ~ 50 vol % void fraction. Initially, the can has about 1.5 L of void space to which nitric acid can be added to dissolve the oxide.

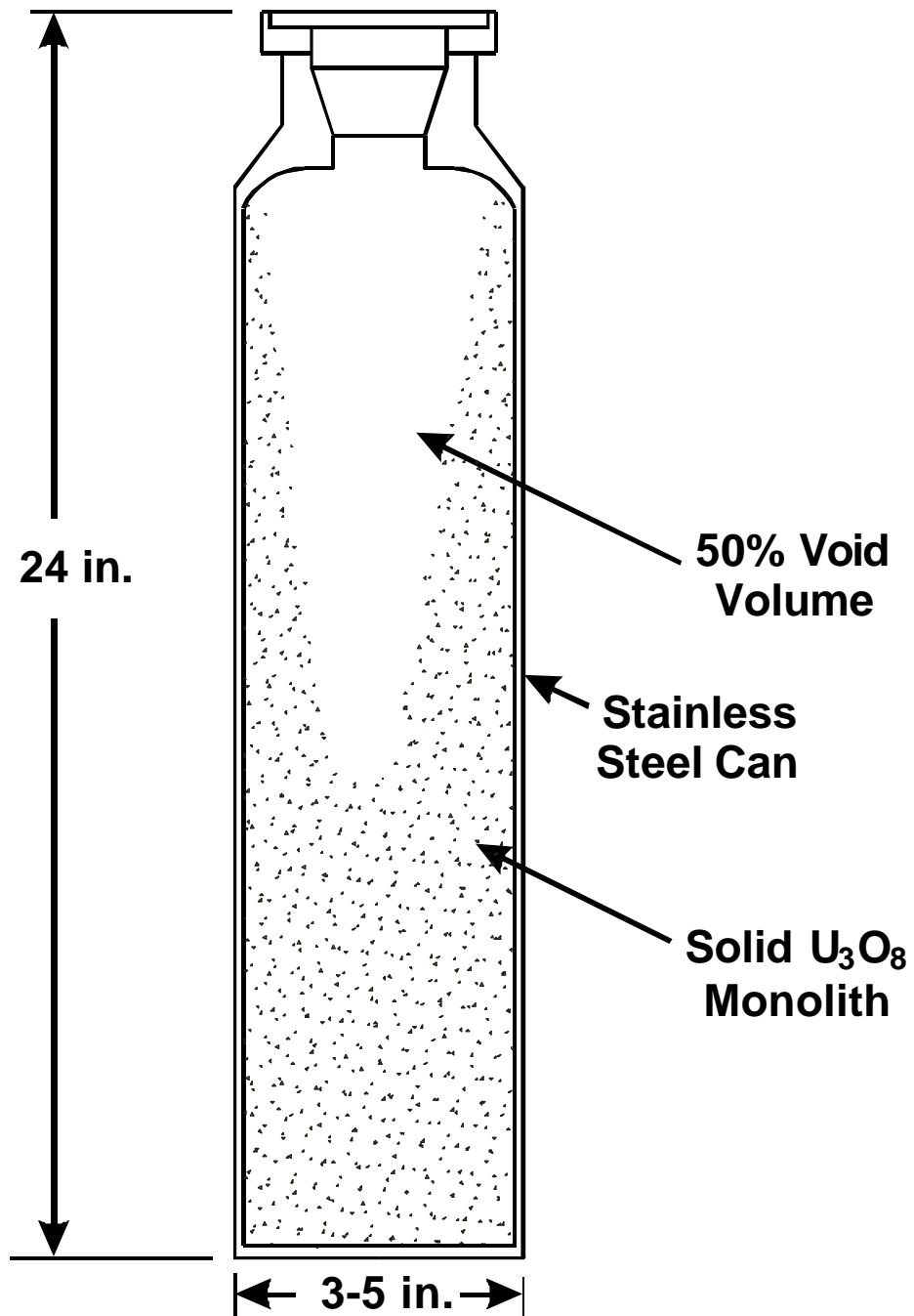

Fig.C.1. CEUSP can assembly for monolithic uranium oxide storage.

In-can dissolution tests were conducted using surrogate CEUSP product made from DU, cadmium, and gadolinium oxides by the same method as that used in the CEUSP process. The cans were opened at the top, and an air-sparge tube was inserted into the void space for agitation. The void space was filled with 6 to 8 *M* nitric acid at room temperature. In these tests, the off-gas from the can, which did not appear to cause problems, was sent to the cell exhaust system. After reacting for a predetermined time, the acid was decanted, and fresh acid was added until dissolution was completed. Approximately 1 to 2 d were required to dissolve the material under the conditions used.

Appendix D

CURRENT TECHNICAL CONSTRAINTS FOR WIPP

D.1 INTRODUCTION

This appendix is a discussion of the technical constraints and limitations on the disposition of ^{233}U -bearing materials in a geologic repository like WIPP.

For disposal, TRUW containing ^{233}U is acceptable at WIPP if it meets the WAC documented in the latest version of the WIPP WAC report (DOE Carlsbad Area Office April 1996). For a waste to be certified as TRUW, its TRU content must exceed 100 nCi/g. If that requirement is met, other radionuclides such as ^{233}U may be present as co-contaminants. A waste stream with only ^{233}U as a contaminant would not be acceptable for WIPP. As a provision of DOE Order 5820.2A (DOE September 26, 1988) indicates, sites may elect to handle (i.e., treat, transport, and store) wastes contaminated with ^{233}U as TRUW based on the potential hazards. However, according to the WIPP Land Withdrawal Act (U.S. Congress 1996), such materials cannot be shipped to WIPP for disposal.

Also, a significant inventory of wastes exist containing ^{233}U with no TRU radionuclides (Forsberg, Storch, and Lewis July 7, 1998). Although these wastes cannot go to WIPP, the WIPP WAC document provides the best current (but not legally binding) definition of waste form and packaging requirements for eventual disposal of ^{233}U wastes. WIPP is designed for wastes for which the primary hazard is alpha radiation. The primary hazard of ^{233}U is alpha radiation; thus, WIPP is technically suitable for accepting ^{233}U wastes and has suitable WAC for this purpose.

By law (U.S. Congress 1996), WIPP is authorized to receive and dispose of 175,600 m³ of TRUW generated from defense operations. In its EIS for WIPP (DOE September 1997), DOE has determined that another 142,000 m³ of wastes may require disposal by 2033 in a geologic disposal facility such as WIPP. Much of this waste does not yet exist in packaged form; it will be generated as old cold-war facilities are decontaminated and decommissioned. These wastes include added defense TRUW, other government TRUW generated from nondefense activities, and other wastes that may require geological disposal. The other wastes include *existing* wastes containing ^{233}U that are in storage—primarily at ORNL and INEEL (Forsberg, Storch, and Lewis July 7, 1998). Because of the 142,000 m³ of other wastes that ultimately will require disposal, (1) a second WIPP-type facility must be built, (2) WIPP must be expanded with congressional authorization to accept these other materials, or (3) some new option must be identified.

D.2 WACs FOR ^{233}U

Based on the WIPP WAC, Table D.1 lists the controlling WAC for a ^{233}U waste authorized for disposal in a WIPP-type repository. Section D.3 provides a more detailed description of the WIPP WAC that were used to derive Table D.1. Three criteria limit the amount of ^{233}U that can be placed in a 55-gal drum:

- *Weight (or mass).* Total drum weight (i.e., weight of both the drum itself and the waste content) is limited by the capacity of WIPP waste-handling equipment and vehicle-weight limits.
- *Nuclear criticality.* The WIPP facility uses a criticality control strategy dependent upon mass limits of fissile materials in WPs. For CH waste, this limit is 200 g ^{233}U in a 55-gal drum. In the current design of the RH waste canister, which can hold up to three 55-gal drums, there is also a container limit of 325 g. This limit is imposed by the specific transport vehicle and is not a repository limit. With an alternative transport system, each 55-gal drum of RH waste could accept 200 g of ^{233}U .

The WIPP facility is technically designed for alpha wastes, which include ^{233}U . Unlike plutonium and most other fissile materials, ^{233}U can be isotopically diluted with DU as an alternative method to eliminate criticality problems. The WIPP WAC do not consider isotopic dilution as a criticality control strategy because no significant quantities of ^{233}U were expected to be disposed of in this facility. However, this alternative criticality control strategy, which is applicable only to fissile uranium isotopes, eliminates all mass criticality limits for ^{233}U .

- *Alpha activity limits.* The WIPP WAC limit the quantity of alpha materials per container with different limits for untreated vs treated wastes. These criteria are designed to limit the potential consequences of certain types of accidents.

As is evident from Table D.1, WIPP criticality criteria control the maximum quantities of ^{233}U in a WP if mass limits are used as a criticality control strategy for ^{233}U . This limit is 200 g of ^{233}U per drum. If the ^{233}U is isotopically diluted with DU, this limit no longer applies.

If criticality criteria do not control the amount of ^{233}U in a WP, other WAC would limit the ^{233}U per 55-gal drum. For untreated CH waste, the alpha activity limit of 1.3 kg ^{233}U /55-gal drum is limiting. For CH-treated waste, the maximum container weight limit, ~450 kg/55-gal drum, controls the ^{233}U content per drum. To control nuclear criticality by isotopic dilution, ~188 kg of DU (0.2 wt % ^{235}U) is required per kilogram of ^{233}U . If the drum weight limit is ~450 kg and the waste form is assumed to be solid uranium metal, the drum can contain ≤ 2.2 kg of ^{233}U . For RH wastes, the weight limits and alpha activity limits are by coincidence almost identical with the slightly more restrictive alpha activity limits, which restrict the ^{233}U per container to 16 kg ^{233}U or 5.3 kg per equivalent 55-gal drum.

Table D.1. Summary of WIPP WAC as applied to ²³³U

Constraint	Waste category	
	CH	RH
Container	55-gal drum	RH container (accepts three 55-gal drums)
Weight limit (gross)	450 kg	3,600 kg
Criticality control strategy		
Mass limits	200 g/drum	325 g/container
Isotopic dilution	No limit	No limit
Activity limits		
Untreated waste	1.3 kg ²³³ U	16 kg ²³³ U
Solidified waste	29 kg ²³³ U	16 kg ²³³ U
Radiation dose limit	≤200 mrem/h	>200 mrem/h and <1,000 mrem/h

D.3 WIPP WAC

The WIPP WAC document identifies the requirements that must be met by participating sites before any TRUWs are shipped for disposal to the WIPP facility. As stated in the “Executive Summary” of the WIPP WAC document, “The WIPP Project will comply with applicable federal and state regulations and requirements, including those in Titles 10, 40, and 49 of the *Code of Federal Regulations* (CFR). The WAC document, DOE/WIPP-069, serves as the primary directive for assuring the safe handling, transportation, and disposal of defense TRU wastes in the WIPP and for certification of these wastes. The WAC document identifies the requirements that must be met by participating Sites before these TRU wastes may be shipped for disposal in the WIPP facility.”

As a consequence of this commitment, the WIPP Project is required to comply with the following title sections of the CFR:

- NRC and DOE standards in CFR Title 10
- EPA standards in CFR Title 40
- DOT standards in CFR Title 49.

The WIPP WAC reports separate criteria for CH and RH TRUWs. For RH TRUW, the WACs reported in the WIPP WAC document are preliminary in nature. For CH TRUW, all weight criteria must be met, and these are summarized in Table D.2. WIPP WAC packaging configurations, authorized for CH TRUW shipments, are given in Table D.3. Different payload configurations are restricted by different weight requirements for CH TRUW payload containers, TRU package transporter Type II (TRUPACT-II) shipments, and loaded TRUPACT-IIs. For example, a payload assembly of fourteen 55-gal drums may not exceed 3,300 kg (7,265 lb) even through the maximum weight of a 55-gal drum may be 450 kg (1,000 lb).

The WIPP WAC also mentions that although the maximum weight of a payload assembly must not exceed 3,300 kg (7,265 lb), the weight available for the CH TRUW payload assembly will be less depending on the as-built weight of a TRUPACT-II to be used. [The average as-built weight of production TRUPACT-II's is 5,670 kg (12,705 lb).] The weight available for the CH TRUW waste payload assembly is obtained by subtracting the as-built weight of a TRUPACT-II from the maximum gross weight, which as Table D.2 shows, is 8,730 kg (19,250 lb). The maximum gross weight per TRUPACT-II is based on an approximate as-built weight of 5,920 kg (13,050 lb) and an average payload weight of 2,810 kg (6,200 lb), which is usually the limiting weight for two TRUPACT-II's per shipment. DOT's limit of 36,300 kg (80,000 lb) gross vehicle-weight rating must also be met; this is the limiting weight for three TRUPACT's per shipment.

Several criteria reported in the WIPP WAC are based on parameters normalized to the radiological properties of ^{239}Pu . A comparison of some pertinent radiological properties of uranium isotopes with those of ^{239}Pu is provided in Table D.4. This table indicates that the fissile gram equivalent (FGE) of ^{233}U is 0.9 that of ^{239}Pu (Chapman July 23, 1998). However, Appendix 1.3.7 (Table 10.1) of the TRUPACT-II safety analysis report (SAR) (DOE Carlsbad Area Office 1994) indicates a value of 1.00 for the FGE of both ^{233}U and ^{239}Pu . To be conservative, the latter value (expressing ^{233}U 's equivalence with ^{239}Pu) is used for the FGE of ^{233}U in this assessment.

Several TRUW acceptance criteria specified in the WIPP WAC document directly impact the thresholds of ^{233}U -bearing waste materials. Separate summaries of these requirements are provided for CH TRUW in Table D.5a and for RH TRUW in Table D.5b. The criticality data for CH-TRUW in Table D.5a are based on the WIPP WAC specifications for the maximum allowable fissile material for the standard shipping container (TRUPACT-II). These specifications are given for various payload containers in Table D.6.

As previously indicated, the RH TRUW requirements listed in Table D.5b are preliminary in nature. Current plans are to ship RH TRUWs in a specially designed container called the RH TRU 72-B Cask. The design specifications and requirements of this shipping package are reported in the current SAR for the RH TRU 72-B Shipping Cask (DOE Carlsbad Area Office September 1996).

Table D.2. WIPP CH TRUW container and assembly weight criteria^a

Component	Maximum gross weight	
	lb	kg
<i>Individual payload container</i>		
55-gal steel drum (DOT specification 17C)	≤ 1,000	≤ 450
55-gal steel drum (DOT specification 17H)	≤ 1,000	≤ 450
55-gal steel drum (UN/1A2/X320/S)	≤ 700	≤ 320
55-gal steel drum (UN/1A2/X325/S)	≤ 716	≤ 325
55-gal steel drum (UN/1A2/X400/S)	≤ 882	≤ 400
55-gal steel drum (UN/1A2/X425/S)	≤ 937	≤ 425
55-gal steel drum (UN/1A2/X430/S)	≤ 948	≤ 430
55-gal steel drum (UN/1A2/X435/S)	≤ 959	≤ 435
55-gal steel drum overpacked in a standard waste box (SWB)	≤ 1,450	≤ 660
SWB ^b	≤ 4,000	≤ 1,810
10-drum overpack (TDOP)	≤ 6,700	≤ 3,040
<i>Pipe overpack payload container</i>		
Pipe overpack 6-in.-diam	≤ 328	≤ 150
Pipe overpack 12-in.-diam	≤ 547	≤ 250
<i>Payload container assembly</i>		
Payload container assembly	≤ 7,265	≤ 3,300
TRUPACT-11	≤ 19,250	≤ 8,730
Truck (tractor/trailer)	≤ 80,000	≤ 36,300

^aBased on Table 3.2.2.2 of the WIPP WAC document (DOE Carlsbad Area Office April 1996).

^bSWB = standard-waste box.

Table D.3. Maximum number of CH TRUW containers per TRUPACT-II and authorized packaging configurations^a

Number	Type of container(s) per TRUPACT-II
14	55-gal drums
14	pipe overpacks in 55-gal drums
2	SWBs
2	SWBs, each containing one bin
2	SWBs, each containing four 55-gal drums
1	TDOP, containing ten 55-gal drums
1	TDOP, containing one SWB
1	TDOP, containing one bin within a SWB
1	TDOP, containing four 55-gal drums with an SWB

^aBased on Table 3.2.1.2 of the WIPP WAC document (DOE Carlsbad Area Office April 1996).

Table D.4. Comparison of uranium isotope and ²³⁹Pu characteristics^a

Characteristic	Unit(s)	Radionuclide				
		²³² U	²³³ U	²³⁵ U	²³⁸ U	²³⁹ Pu
Half-life	Years	6.89E+01	1.59E+05	7.04E+08	4.47E+09	2.41E+04
Specific activity	Ci/g	2.14E+01	9.68E-03	2.16E-06	3.36E-07	6.22E-02
Specific power	W/g	6.73E-01	2.77E-04	5.86E-08	8.38E-09	1.88E-03
²³⁹ Pu FGE ^b	g	0	1.00	1.00	0	1.00
Subcritical mass limit	g	0	500	700	0	450
L(39)/L(i) ^c		0	0.90	0.64	0	1.00
²³⁹ Pu E-Ci	Ci	80	390	430	430	100
²³⁹ Pu E-g	g	3.7	40,290	1.99E+08	1.28E+09	1,610
Lung class ^d	W, Y	Y	Y	Y	Y	W
Weighting factor		0.8	3.9	4.3	4.3	1.0

^aAdapted from Chapman July 23, 1998; Carlsbad Area Office 1994; and DOE Office of Environment, Safety, and Health July 1988.

^bPlutonium-239 FGE, as reported in Appendix 1.3.7 of the *TRUPACT-II Safety Analysis Report for Packaging* (DOE Carlsbad Area Office 1994). The ²³⁹Pu FGE is an isotopic mass of a radionuclide that has been normalized to ²³⁹Pu.

^cRatio of the ²³⁹Pu subcritical mass limit to the subcritical mass limit of a particular nuclide. Used for calculating ²³⁹Pu FGE.

^dExpressed as weekly (W) or yearly (Y).

Table D.5a. Summary of CH TRUW acceptance criteria requirements that pertain to ^{233}U waste thresholds

Requirement	As documented in WIPP WAC ^a	Metric or ^{233}U equivalent
Container criteria		
Description	DOT Type A 55-gal drums or SWBs	DOT Type A 55-gal drums or SWBs
Container/assembly weight	$\leq 1,000$ lb/55-gal drum $\leq 4,000$ lb/SWB \leq TRUPACT-II weight limits	≤ 450 kg/55-gal drum $\leq 1,800$ kg/SWB \leq TRUPACT-II weight limits
Container weight limit	≤ 60 lb/55-gal drum	≤ 27 kg/55-gal drum
Nuclear criteria		
Criticality (^{239}Pu FGE/container) ^b	<200 g/55-gal drum <325 g/SWB $<$ TRUPACT-II limits	<200 g/55-gal drums <325 g/SWB $<$ TRUPACT-II limits
Activity (PE-Ci/container) ^c		
Untreated waste	≤ 80 PE-Ci/55-gal drum ≤ 130 PE-Ci/SWB $\leq 1,800$ PE-Ci/55-gal drum overpacked in in SWB or TDOP	≤ 1.3 PE-kg/55-gal drum ≤ 2.1 PE-kg/SWB ≤ 29 PE-kg/55-gal drum overpacked in SWB or TDOP
Solidified/vitrified waste	$\leq 1,800$ PE-Ci/55-gal drum	≤ 29 PE-kg/55-gal drum
Thermal power	Report if >0.1 W/ft ³ <40 W per TRUPACT-II	Report if >3.5 W/m ³ <145 kg ^{233}U per TRUPACT-II
TRU-alpha activity ^d	>100 nCi/g (waste matrix)	>100 nCi/g (waste matrix)
Contact dose rate	>100 nCi/g (waste matrix) ≤ 200 mrem/h	≤ 200 mrem/h

^aAs specified in the WIPP WAC document (DOE Carlsbad Area Office April 1996).

^bSee also Table E.6.

^cRadioactivity (per container) expressed in units of ^{239}Pu equivalent curies.

^dActivity of alpha-emitting TRU isotopes with half-lives >20 years.

Table D.5b. Summary of RH TRUW preliminary acceptance criteria requirements that pertain to ^{233}U waste thresholds

Requirement	As documented in WIPP WAC ^a or SAR ^b	Metric or ^{233}U equivalent
Container criteria		
Description	DOT Type A RH canister ^c	DOT Type A RH canister ^c
Weight limit for canister and contents	$\leq 8,000$ lb	$\leq 3,630$ kg
Weight of empty canister	1,762 lb	800 kg
Weight limit for waste contents in canister	$\leq 6,238$ lb	$\leq 2,830$ kg
Nuclear criteria		
Criticality (^{239}Pu FGE/cask)	< 325 g	< 325 g
Activity (^{239}Pu -E/canister)	$\leq 1,000$ PE-Ci	16 PE-kg
Thermal power (canister)	< 300 W	$< 1,080$ kg ^{233}U
TRU-alpha activity ^d	> 100 nCi/g (waste matrix) and ≤ 23 Ci/L	> 100 nCi/g (waste matrix) and ≤ 2.3 kg $^{233}\text{U/L}$
Contact dose rate		
Per canister	$\leq 1,000$ rem/h Preapproval for > 100 rem/h	$\leq 1,000$ rem/h Preapproval for > 100 rem/h
Per cask	≤ 200 mrem/h	≤ 200 mrem/h

^aAs specified in the WIPP WAC document (DOE Carlsbad Area Office April 1996).

^bAs specified in the SAR for the RH-TRU 72-B shipping cask (DOE Carlsbad Area Office September 1996).

^cA shipping container that holds three 55-gal drums.

^dActivity of alpha-emitting TRU isotopes with half-lives > 20 years.

Table D.6. Maximum allowable fissile material, expressed as ^{239}Pu FGE for CH TRUW in the TRUPACT-II^a

Payload container	Mass of maximum allowable fissile material (^{239}Pu FGE)
55-gal drum	200
SWB	325
TDOP	325
Pipe component overpacked in a 55-gal drum	200
TRUPACT-II	325
TRUPACT-II (14 pipe overpacks)	2,800

^aAdapted from Table 3.3.1.2 of the WIPP WAC document (DOE Carlsbad Area Office April 1996).

A comparison of WIPP-based nuclear criteria for selected radionuclides is provided for CH TRUW and RH TRUW in Tables D.7a and D.7b, respectively. Each table lists separate criteria for ^{239}Pu and four uranium isotopes: ^{232}U , ^{233}U , ^{235}U , and ^{238}U .

A sample sensitivity analysis is provided in the following to show the impacts of the WIPP WAC and isotopic dilution on ^{233}U packaging in 55-gal drums. Four cases (A, B, C, and D) are considered, one of which shows the amount of ^{233}U (in the form of $^{233}\text{UO}_2$) that could be placed into a 55-gal drum if the ^{233}U content were isotopically diluted to 0.53 wt % in DU, which has 0.20 wt % ^{235}U . This assessment is made to show also the quantity of ^{233}U (in the form of $^{233}\text{UO}_2$) that could be placed into a 55-gal drum under four different conditions. For the four cases considered, the results are summarized in the following for a nominal 1 t domestic ^{233}U inventory:

D.3.1 Case A

WIPP WAC for CH TRUW as $^{233}\text{UO}_2$ in a 55-gal drum:

- Controlling factor
 - Nuclear criticality limit: $0.200 \text{ kg (as } ^{233}\text{U)} = 0.227 \text{ kg (as } ^{233}\text{UO}_2\text{)}$.
- Resulting number of 55-gal drums needed from a 1,000-kg ^{233}U inventory = $1,000 \text{ kg} / 0.200 \text{ kg } ^{233}\text{U per drum} = 5,000 \text{ drums}$.

Table D.7a. Comparison of WIPP-based nuclear criteria for various radionuclides comprising CH TRUW^a

Nuclear criteria	Units	Radionuclide				
		²³² U	²³³ U	²³⁵ U	²³⁸ U	²³⁹ Pu
Maximum criticality limits						
55-gal drum	²³⁹ Pu FGE (g)	0	200	200	0	200
SWB	²³⁹ Pu FGE (g)	0	325	325	0	325
TRUPACT-II	²³⁹ Pu FGE (g)	0	325	325	0	325
TRUPACT-II (with 14 pipe overpacks)		0	2,800	2,800	0	2,800
Maximum activity limits						
Untreated waste						
55-gal drum	PE-Ci	64	312	340	340	80
SWB	PE-Ci	100	510	560	560	130
TDOP	PE-Ci	1,440	7,020	7,740	7,740	1,800
Solidified/vitrified waste						
55-gal drum	PE-Ci	1,440	7,020	7,740	7,740	1,800

^aAdapted from the WIPP WAC document (DOE Carlsbad Area Office April 1996).

Table D.7b. Comparison of WIPP-based nuclear criteria for various radionuclides comprising RH TRUW^a

Nuclear criteria	Units	Radionuclide				
		²³² U	²³³ U	²³⁵ U	²³⁸ U	²³⁹ Pu
Maximum criticality limits						
55-gal drum	²³⁹ Pu FGE (g)	0	200	200	0	200
SWB	²³⁹ Pu FGE (g)	0	325	325	0	325
RH TRU 72-B shipping cask ^b	²³⁹ Pu FGE (g)	0	325	325	0	325
Maximum activity limits						
Untreated waste	PE-Ci	NA ^c	NA	NA	NA	NA
Solidified/vitrified waste	PE-Ci	NA	NA	NA	NA	NA

^aAdapted from the WIPP WAC document (DOE Carlsbad Area Office April 1996).

^bBased on SAR for RH TRU 72-B shipping cask (DOE Carlsbad Area Office September 1996).

^cNA = not applicable (i.e., no activity limits are specifically indicated for untreated and treated wastes).

D.3.2 Case B

Isotopic dilution of solidified CH TRUW as ²³³UO₂ in a 55-gal drum (if the ²³³U is considered untreated waste, the mass limit per drum of ²³³U is 450 kg):

- Controlling factor
 - Maximum permissible mass of drum contents (after subtracting drum weight): 426.4 kg (as UO₂) = 375.8 kg (as U).
- Mass of ²³³U per isotopically diluted drum = 0.0053 × 375.8 kg = 1.992 kg.
- Resulting number of 55-gal drums needed from a 1,000 kg ²³³U inventory = 1,000 kg/1.992 kg ²³³U per drum = 502 drums.

D.3.3 Case C

WIPP WAC for RH TRUW as $^{233}\text{UO}_2$ in two or three 55-gal drums in an RH TRU 72-B shipping canister:

- Controlling factor
 - Nuclear criticality limit: $0.325 \text{ kg (as } ^{233}\text{U}) = 0.369 \text{ kg (as } ^{233}\text{UO}_2\text{)}$.
- Restriction: a single drum can contain $\leq 0.200 \text{ kg } ^{233}\text{U}$. The remaining mass of $0.125 \text{ kg } ^{233}\text{U}$ allotted for an RH TRU 72-B shipping canister must go into one or two more drums.
- Assuming only one more drum is needed, then the resulting number of 55-gal drums needed from a $1,000 \text{ kg } ^{233}\text{U}$ inventory = $1,000 \text{ kg} / 0.325 \text{ kg } ^{233}\text{U per 2 drums} = 6,154$ drums.

D.3.4 Case D

Isotopic dilution of RH TRUW as $^{233}\text{UO}_2$ in three 55-gal drums in an RH TRU 72-B shipping canister:

- Controlling factor
 - Maximum permissible mass of an RH canister containing three 55-gal drums (gross canister weight limit is 3630 kg; canister weight is 800 kg): $2830 \text{ kg (as } \text{UO}_2\text{)} = 2494.5 \text{ kg (as } \text{U}) = 831.5 \text{ kg (as } \text{U per 55-gal drum)}$.
- Mass of ^{233}U in an isotopically diluted drum = $0.0053 \times 831.5 \text{ kg} = 4.407 \text{ kg}$.
- Resulting number of 55-gal drums needed from a $1,000 \text{ kg } ^{233}\text{U}$ inventory: $= 1,000 \text{ kg} / 4.407 \text{ kg/drum} = 227$ drums.

For both CH and RH wastes, these results show that isotopic dilution results in very significant reductions in the number of 55-gal drums that would be required for the disposition of a domestic ^{233}U inventory. In the previous examples, isotopic dilution results in a requirement of nearly 4,500 fewer drums for CH wastes (Case B vs Case A) and nearly 5,930 fewer drums for RH wastes (Case D vs Case C). The cost savings associated with these potential differences can be shown to be very significant.

The *WIPP Disposal Phase Final EIS* (DOE Carlsbad Area Office September 1997) indicates the following costs [in millions (M) of 1994 dollars (\$)]:

- Total life-cycle cost for TRUW program: \$19,030M.
- Total life-cycle costs for waste treatment: \$12,140M.

The difference between Items 1 and 2 above gives an estimated total cost of \$6,890M for waste transport and disposal. This cost is for about 168,500 m³ of waste. Expressing this cost on a unit volume basis gives $(\$6,890M)/(168,500 \text{ m}^3) = \$40,890/\text{m}^3$. Since the volume capacity of a 55-gal drum is 0.2082 m³, this unit cost can be expressed as ~\$8,500/drum. Applying this result to the drum inventory savings previously indicated gives a total potential cost savings of ~\$38M for a domestic ²³³U inventory of CH wastes and about \$50M for a domestic ²³³U inventory of RH wastes.

D.4 GLOSSARY OF TERMS FOR APPENDIX D

Canister gross weight: Total weight of a waste canister and its contents.

Dunnage: Loose packing material used to protect a waste container's contents from damage during transport.

FGE (²³⁹Pu): An isotopic mass of a radionuclide that has been normalized to ²³⁹Pu.

Overpack: A payload container placed around another container to control contamination, or enclose a damaged container.

Package: The reusable Type B shipping container (i.e., TRUPACT-II or RH-TRUW 72-B Cask) loaded with TRUW payload containers, which has been prepared for shipment in accordance with the TRUW Packaging QA Program.

Packaging: The reusable Type B shipping container for transport of TRUW payload containers (i.e., TRUPACT-II or RH-TRUW 72-B Cask). A transportation device consisting of an assembly of components necessary to ensure compliance with the requirements of Titles 49 CFR Part 173, Subpart 1 ("Shippers-General Requirements and Packaging") and 10 CFR Part 71 ("Packaging and Transportation of Radioactive Material").

Payload container: The outermost container for TRUW material that is placed in a reusable Type B shipping container (i.e., TRUPACT-II or RH-TRUW 72-B Cask) for transport.

Payload container assembly: An assembly of payload containers, such as a seven-pack of drums, which is intended to be handled and emplaced as a single unit.

Plutonium equivalent curie (PE-Ci): An equivalent radiotoxic hazard (radioactivity) of a radionuclide normalized to ²³⁹Pu.

Standard waste box (SWB): A payload container authorized for use with TRUPACT-II Transportation Packages that meet DOT Specification 7A Type A.

Ten drum overpack (TDOP): A specialized payload container authorized for use within the TRUPACT-II packaging that meets DOT specification 7A Type A.

Thermal power (or decay heat): A measure of the rate of heat-energy emission that results from the radioactive decay of a material. A unit of thermal power commonly used is the watt (W).

Transuranic waste (TRUW): Radioactive waste that, at the time of assay, contains >100 nCi/g of alpha-emitting isotopes with atomic numbers >92 and half-lives >20 years.

TRUW, contact-handled (CH): Packaged TRUW with an external contact dose rate at the container surface that is ≤ 200 mrem/h.

TRUW, remote-handled (RH): Packaged TRUW with an external contact dose rate at the container surface that is >200 mrem/h. For WIPP, there is an upper limit of 1000 rem/h.

TRU alpha activity: Radioactivity (Ci) from the alpha radiation of TRU radionuclides.

TRUPACT-II: Transuranic Package Transporter II; An NRC-certified, Type B transportation packaging used for the shipment of CH TRUW.

D.5 REFERENCES FOR APPENDIX D

Chapman, J. A., July 23, 1998. Oak Ridge National Laboratory, Oak Ridge, Tennessee, "WIPP Parameters," correspondence to Stephen N. Storch, Oak Ridge National Laboratory, Oak Ridge, Tennessee.

Forsberg, C. W., S. N. Storch, and L. C. Lewis, July 7, 1998. *Uranium-233 Waste Definition: Disposal Options, Safeguards, Criticality Control, and Arms Control*, ORNL/TM-13591, Lockheed Martin Energy Research Corp., Oak Ridge National Laboratory, Oak Ridge, Tennessee.

U. S. Congress, 1996. *Waste Isolation Pilot Plant Land Withdrawal Act*, Public Law 102-579, as amended.

U. S. Department of Energy, Carlsbad Area Office, 1994. *Safety Analysis Report for the TRUPACT-II Shipping Package (SARP)*, U.S. NRC Docket No. 71-9218, DOE/WIPP-97003692, Carlsbad, New Mexico.

U. S. Department of Energy, Carlsbad Area Office, April 1996. *Waste Acceptance Criteria for the Waste Isolation Pilot Plant*, DOE/WIPP-069, Rev. 5, Carlsbad, New Mexico.

U. S. Department of Energy, Carlsbad Area Office, September 1996. *Safety Analysis Report for the RH-TRU 72-B Shipping Cask*, U.S. NRC Docket No. 71-9212, Rev. 0, Carlsbad, New Mexico.

U. S. Department of Energy, Carlsbad Area Office, September 1997. *Waste Isolation Pilot Plant Disposal Phase Final Supplemental Environmental Impact Statement*, DOE/EIS-0026-S-2, Carlsbad, New Mexico.

U. S. Department of Energy, Office of Environment, Safety, and Health, July 1988. *Internal Dose Conversion Factors for Calculation of Dose to the Public*, DOE/EH-0071, Washington, D.C.

U. S. Department of Energy, September 26, 1988. DOE Order 5820.2A, *Radioactive Waste Management*, Washington, D.C.

INTERNAL DISTRIBUTION

- | | | | |
|--------|------------------|--------|----------------------------|
| 1. | C. W. Alexander | 37. | G. T. Mays |
| 2-6. | E. C. Beahm | 38. | L. E. McNeese |
| 7. | J. M. Begovich | 39-41. | G. E. Michaels |
| 8. | P. J. Bereolos | 42. | H. J. Monroe |
| 9. | L. F. Blankner | 43. | D. L. Moses |
| 10. | H. E. Clark | 44. | R. J. Moses |
| 11. | E. D. Collins | 45. | B. D. Patton |
| 12. | S. O. Cox | 46. | D. W. Ramey |
| 13. | A. G. Croff | 47. | D. E. Reichle |
| 14-15. | L. R. Dole | 48. | K. D. Rowley |
| 16. | W. D. Duerksen | 49. | J. E. Rushton |
| 17. | K. R. Elam | 50. | A. R. Sadlowe |
| 18-22. | C. W. Forsberg | 51. | B. W. Starnes |
| 23. | E. C. Fox | 52-56. | S. N. Storch |
| 24. | S. R. Greene | 57. | J. R. Trabalka |
| 25. | M. J. Haire | 58. | D. Turner |
| 26-30. | R. F. Holdaway | 59. | O. F. Webb |
| 31. | C. M. Hopper | 60. | K. A. Williams |
| 32-34. | A. S. Icenhour | 61. | Central Research Library |
| 35. | A. M. Krichinsky | 62. | Laboratory Records-RC |
| 36. | S. B. Ludwig | 63. | Document Reference Section |

EXTERNAL DISTRIBUTION

64. Joe Arango, U.S. Department of Energy, S-3.1, Rm. 6H-025, 1000 Independence Ave., S.W., Washington, D.C. 20585.
65. M. W. Barlow, Westinghouse Savannah River Co., Savannah River Site, Bldg. 704-C, Aiken, South Carolina 29808.
66. W. E. Bickford, Westinghouse Savannah River Co., Savannah River Site, Bldg. 773-41A, Aiken, South Carolina 29808.
67. Scott Boeke, Westinghouse Savannah River Co., Savannah River Site, Aiken, South Carolina 29808.
68. Mark C. Bronson, Lawrence Livermore National Laboratory, P.O. Box 808, Livermore, California 94550.
69. Bill Brummend, Lawrence Livermore National Laboratory, P.O. Box 808, Livermore, California 94550.

70. Mathew Bunn, National Academy of Sciences, Founder's Bldg., 1055 Thomas Jefferson Street, N.W., Washington, D.C. 20007.
71. H. R. Canter, U.S. Department of Energy, Office of Fissile Materials Disposition, 1000 Independence Ave., S.W., Washington, D.C. 20585.
72. Alice Caponiti, U.S. Department of Energy, Office of Fissile Materials Disposition, 1000 Independence Ave., S.W., Washington, D.C. 20585.
73. Nate Chipman, Idaho National Engineering and Environmental Laboratory, WCB, MS-3114, P.O. Box 1625, Idaho Falls, Idaho 83415-3114.
74. George Christian, Lockheed Martin Idaho Technologies Company, North Building, Suite 1404, 955 L'Enfant Plaza, S.W., Washington, D.C. 20024.
75. John Clouet, TRW Environmental Safety Systems, Inc., M/S 423, 1261 Town Center Dr., Las Vegas, Nevada 89134.
76. Ray Cooperstein, U.S. Department of Energy, Mail Stop DP-45, 19901 Germantown Rd., Germantown, Maryland 20874.
77. A. I. Cygelman, U.S. Department of Energy, Office of Fissile Materials Disposition, DOE/MD-3, Forrestal Bldg., 1000 Independence Ave., S.W., Washington, D.C. 20585.
78. P. D'Entromont, Westinghouse Savannah River Co., Savannah River Site, Aiken, South Carolina 29808.
79. Paul Daniel, U.S. Department of Energy, Yucca Mountain Site Characterization Office, M/S 523, Suite A, 1551 Hillshire Dr., Las Vegas, Nevada 89134.
80. Bill Danker, U.S. Department of Energy, DOE/MD-3, Forrestal Bldg., 1000 Independence Ave., S.W., Washington, D.C. 20585.
81. Wesley Davis, TRW Environmental Safety Systems, Inc., M/S 423, 1261 Town Center Dr., Las Vegas, Nevada 89134.
82. John Dickenson, Westinghouse Savannah River Co., Savannah River Site, Aiken, South Carolina 29808.
83. A. Disabatino, Lawrence Livermore National Laboratory, P.O. Box 808, Livermore, California 94550.
84. James Duguid, TRW Environmental Safety Systems, Inc., Suite 800, 2650 Park Tower Dr., Vienna, Virginia 22180.

85. Bart Ebbinghaus, Lawrence Livermore National Laboratory, P.O. Box 808, Livermore, California 94550.
86. Randy Erickson, Los Alamos National Laboratory, MS-F660, P.O. Box 1663, Los Alamos, New Mexico 87545.
87. John Evans, U.S. Department of Energy, 1000 Independence Ave., S.W., Washington, D.C. 20585.
88. Roland Felt, 780 DOE Place, Idaho Falls, Idaho 83415-1216.
89. Dick Frushour, Westinghouse Savannah River Co., Savannah River Site, Aiken, South Carolina 29808.
90. Michael L. Gates, U.S. Department of Energy, Project Planning and Integration, Nuclear Materials Stewardship Project Office, Albuquerque Operations Office, P.O. Box 5400, Albuquerque, New Mexico 87185-5400.
91. Arnold Gnevara, U.S. Department of Energy, DOE/EM-66, 1000 Independence Ave., S.W., Washington, D.C. 20585.
92. Peter Gottlieb, TRW Environmental Safety Systems, Inc., M/S 423, 1261 Town Center Dr., Las Vegas, Nevada 89134.
93. Tom Gould, Lawrence Livermore National Laboratory, P.O. Box 808, Livermore, California 94550.
94. Leonard W. Gray, Lawrence Livermore National Laboratory, MS-L394, P.O. Box 808, Livermore, California 94551.
95. James C. Hall, U.S. Department of Energy, Oak Ridge Operations Office, 20 Administration Rd., Oak Ridge, Tennessee 37831.
96. Reginald Hall, Advanced Integrated Management Service, Suite 203B, 702 S. Illinois Ave., Oak Ridge, Tennessee 37831.
97. R. Harmon, Lockheed Martin Idaho Technologies, Inc., P.O. Box 1625, Idaho Falls, Idaho 83415.
98. Dave Haight, U.S. Department of Energy, Yucca Mountain Site Characterization Office, M/S 523, Suite A, 1551 Hillshire Dr., Las Vegas, Nevada 89134.
99. Roger Henry, P. O. Box 1625, Idaho Falls, Idaho 83415-3805.
100. Laura S. H. Holgate, U.S. Department of Energy, Office of Fissile Materials Disposition, DOE/MD-1, 1000 Independence Ave., S. W., Washington, D.C. 20585.

101. Brent Ives, Lawrence Livermore National Laboratory, 7000 East Ave., Livermore, California 94550.
102. Krishna Iyengar, TRW Environmental Safety Systems, Inc., M/S 423, 1261 Town Center Dr., Las Vegas, Nevada 89134.
103. N. C. Iyer, Westinghouse Savannah River Co., Savannah River Site, Bldg. 773-A, Aiken, South Carolina 29808.
104. Bill Jensen, U.S. Department of Energy, MS 1101, 850 Energy Dr., Idaho Falls, Idaho 38401-1563.
105. Gregory V. Johnson, Westinghouse Savannah River Co., Savannah River Site, Aiken, South Carolina 29808.
106. Hoyt Johnson, U.S. Department of Energy, EM-66, Forrestal Bldg., 1000 Independence Ave., S.W., Washington, D.C. 20585.
107. Ed Jones, Lawrence Livermore National Laboratory, 7000 East Ave., L-634, Livermore, California 94550.
108. J. E. Jones, Jr., Haselwood Enterprises, Inc., Suite 300A, 1009 Commerce Park, Oak Ridge, Tennessee 37830.
109. S. L. Krahn, Defense Nuclear Facilities Safety Board, Suite 700, 625 Indiana Ave., N.W., Washington, D.C. 20004.
110. J. F. Krupa, Westinghouse Savannah River Co., Savannah River Site, Bldg. 773-41A, Aiken, South Carolina 29808.
111. Christi Leigh, Sandia National Laboratories, M/S 0778, P.O. Box 5800, Albuquerque, New Mexico 87185.
112. Rodney Lehman, U.S. Department of Energy, DP-24, 19901 Germantown Rd., Germantown, Maryland 20874.
- 113-117. Leroy Lewis, Lockheed Martin Idaho Technologies Company, P.O. Box 1625, Idaho Falls, Idaho 83415.
118. Betty Ahnde Lin, Princeton University, Center for Energy and Environmental Studies, Engineering Quadrangle, Princeton, New Jersey 08544.
119. Herbert Massie, U.S. Defense Nuclear Facilities Safety Board, Suite 700, 625 Indiana Ave., N.W., Washington, D.C. 20004.
120. Mal McKibben, Westinghouse Savannah River Company, Savannah River Site, Bldg. 773-41A, Rm. 123, Aiken, South Carolina 29808.

- 121-122. Don McWhorter, Westinghouse Savannah River Company, Savannah River Site, Bldg. 704-F, Aiken, South Carolina 29808.
123. Ed Moore, Westinghouse Savannah River Company, Savannah River Site, Bldg. 773-41A, Rm. 125, P.O. Box 616, Aiken, South Carolina 29808.
124. Ram B. Murthy, U.S. Department of Energy, Yucca Mountain Site Characterization Office, M/S 523, Suite A, 1551 Hillshire Dr., Las Vegas, Nevada 89134.
125. Jim Nail, Lockheed Martin Idaho Technologies Company, P.O. Box 1625, Idaho Falls, Idaho 83415.
126. Dave Neiswander, Advanced Integrated Management Services, Inc., Suite 203B, 702 S. Illinois Ave., Oak Ridge, Tennessee 37830.
127. Jon Nielsen, Los Alamos National Laboratory, P.O. Box 1663, Los Alamos, New Mexico 87545.
128. Donald Nitti, TRW Environmental Safety Systems, Inc., M/S 423, 1261 Town Center Dr., Las Vegas, Nevada 89134.
129. David Nulton, U.S. Department of Energy, Office of Fissile Materials Disposition, DOE/MD, 1000 Independence Ave., S.W., Washington, D.C. 20585.
130. H. B. Peacock, Westinghouse Savannah River Co., Savannah River Site, Bldg. 773-A, Aiken, South Carolina 29808.
131. Bill Pearson, Westinghouse Savannah River Co., Savannah River Site, Aiken, South Carolina 29808.
132. K. L. Pilcher, Haselwood Enterprise, Inc., Suite 300A, 1009 Commerce Park, Oak Ridge, Tennessee 37830.
133. Robert P. Rechard, Sandia National Laboratories, New Mexico, P.O. Box 5800, Albuquerque, New Mexico 87185-0779
134. Victor Reis, U.S. Department of Energy, Assistant Secretary, Defense Programs, 1000 Independence Ave., S.W., Washington, D.C. 20585.
135. D. R. Rhoades, U.S. Department of Energy, DP24, 1000 Independence Ave., Washington, D.C. 20585-0002.
136. Gary D. Roberson, U.S. Department of Energy, NMSPO, P.O. Box 5400, Albuquerque, New Mexico 87185-5400.
137. Greg Rudy, U.S. Department of Energy, Bldg. 703-A/E245N, P.O. Box A, Aiken, South Carolina 29802.

138. S. S. Sareen, TRW, Suite 800, 2650 Park Tower Dr., Vienna, Virginia 22180.
139. Linda Seward, Idaho National Engineering and Environmental Laboratory, P.O. Box 1625, Idaho Falls, Idaho 83415.
140. Henry Shaw, Lawrence Livermore National Laboratory, P.O. Box 808, Livermore, California 94550.
141. David Stahl, TRW Environmental Safety Systems, Inc., M/S 423, 1261 Town Center Dr., Las Vegas, Nevada 89134.
142. Robert Stallman, U.S. Department of Energy, 850 Energy Dr., Idaho Falls, Idaho 38401.
143. B. Stevenson, U.S. Department of Energy, Office of Fissile Materials Disposition, 1000 Independence Ave., S.W., Washington, D.C. 20585.
- 144-148. John Thompson, U.S. Department of Energy, Office of Fissile Materials Disposition (DOE/MD), 1000 Independence Ave., S.W., Washington, D.C. 20585.
149. John Tseng, U.S. Department of Energy, DOE/EM-66, Forrestal Bldg., Rm. GA-242, 1000 Independence Ave., S.W., Washington, D.C. 20585.
150. Rich Van Konynenburg, Lawrence Livermore National Laboratory, P.O. Box 808, Livermore, California 94550.
151. Don Vieth, 1154 Cheltenham Place, Maineville, Ohio 45039.
152. C. Vitale-Smith, Lockheed Martin Idaho Technologies, Inc., P.O. Box 1625, Idaho Falls, Idaho 83415.
153. Mike Walrath, Idaho National Engineering and Environmental Laboratory, P.O. Box 1625, Idaho Falls, Idaho 83415.
154. K. E. Waltzer, Westinghouse Savannah River Co., Savannah River Site, Bldg. 703-F, Aiken, South Carolina 29808.
155. Jeff Williams, Idaho National Engineering and Environmental Laboratory, P.O. Box 1625, Idaho Falls, Idaho 83415.
156. Wendell L. Williams, U.S. Department of Energy, MD-3, Forrestal Bldg., 6G-081, 1000 Independence Ave., S.W., Washington, D.C. 20585.
157. C. R. Wolfe, Westinghouse Savannah River Company, Savannah River Site, Bldg. 773-A, Aiken, South Carolina 29808.
158. Loong Yong, Advanced Integrated Management Service, Suite 203B, 702 S. Illinois Ave., Oak Ridge, Tennessee 37831.

159. Jesse L. Yow, Jr., Lawrence Livermore National Laboratory, 7000 East Ave., Livermore, California 94550.
160. Neil R. Zack, Los Alamos National Laboratory, MS-E541, P.O. Box 1663, Los Alamos, New Mexico 87545.
161. Office of Assistant Manager of Energy Research and Development, P.O. Box 2008, DOE-ORO, Oak Ridge, Tennessee 37831-6269.
- 162-163. Office of Scientific and Technical Information, P.O. Box 62, Oak Ridge, Tennessee 37831.