

Contract No. W-7405-eng-26

Reactor Division

FEASIBILITY STUDY OF REMOTE CUTTING AND WELDING  
FOR NUCLEAR PLANT MAINTENANCE

Peter P. Holz

LEGAL NOTICE

This report was prepared as an account of Government sponsored work. Neither the United States, nor the Commission, nor any person acting on behalf of the Commission:  
A. Makes any warranty or representation, expressed or implied, with respect to the accuracy, completeness, or usefulness of the information contained in this report, or that the use of any information, apparatus, method, or process disclosed in this report may not infringe privately owned rights; or  
B. Assumes any liabilities with respect to the use of, or for damages resulting from the use of any information, apparatus, method, or process disclosed in this report.  
As used in the above, "person acting on behalf of the Commission" includes any employee or contractor of the Commission, or employee of such contractor, to the extent that such employee or contractor of the Commission, or employee of such contractor prepares, disseminates, or provides access to, any information pursuant to his employment or contract with the Commission, or his employment with such contractor.

NOVEMBER 1969

OAK RIDGE NATIONAL LABORATORY  
Oak Ridge, Tennessee  
operated by  
UNION CARBIDE CORPORATION  
for the  
U.S. ATOMIC ENERGY COMMISSION

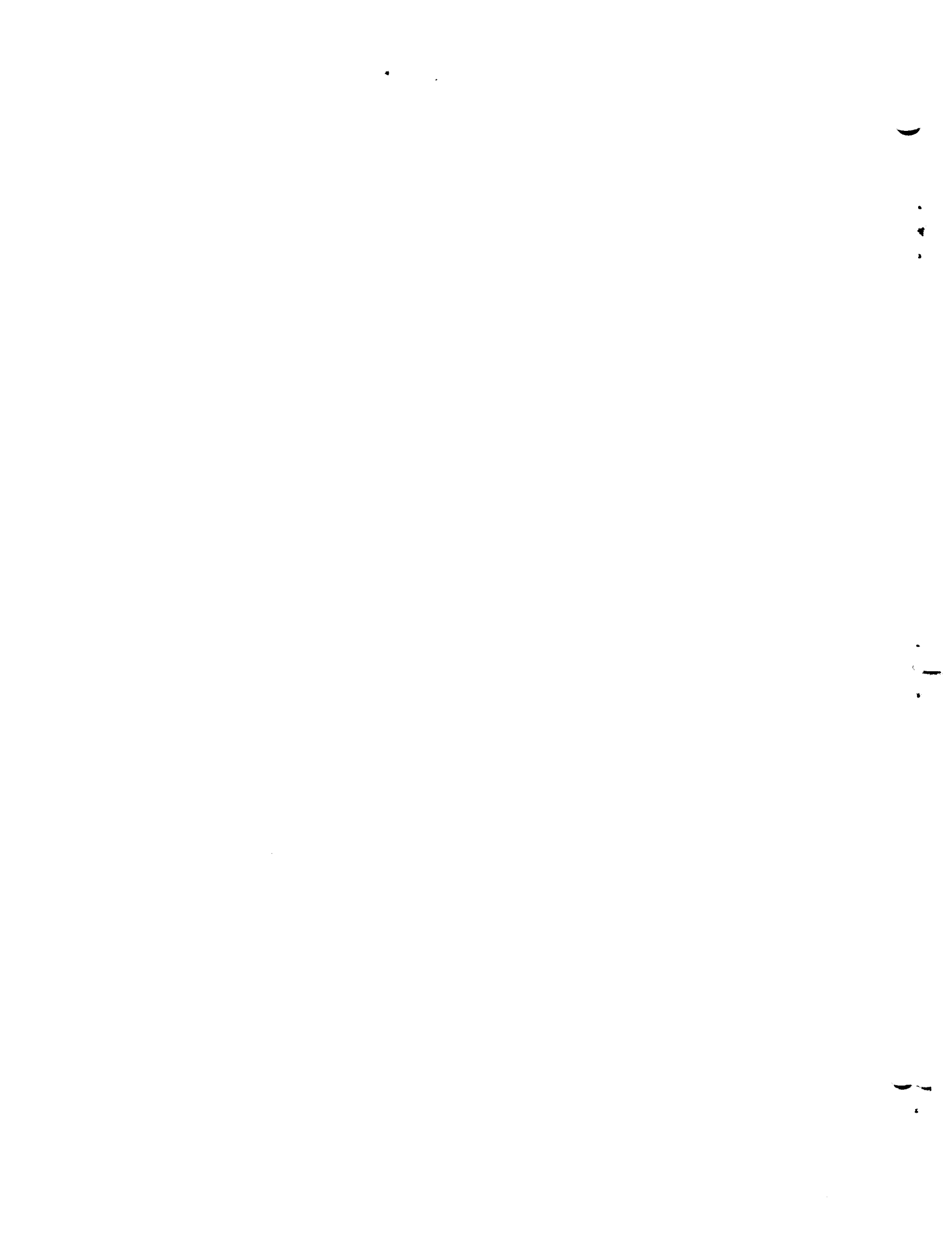

## CONTENTS

	<u>Page</u>
ABSTRACT . . . . .	1
ACKNOWLEDGMENTS . . . . .	2

## SECTION A

1. MAINTENANCE PHILOSOPHY . . . . .	3
1.1 Introduction . . . . .	3
1.2 Approaches to Maintenance . . . . .	4
1.2.1 Some Examples of Maintenance Methods . . . . .	5
1.3 Remote Maintenance Considerations . . . . .	6
1.3.1 Equipment Location for Maintenance . . . . .	6
1.3.2 Mechanical Joint Considerations . . . . .	6
1.3.3 Welded Joint Closure Considerations . . . . .	7
2. HISTORY OF REMOTE WELDING . . . . .	10
2.1 Background . . . . .	10
2.2 The Pennsylvania Advanced Reactor Program . . . . .	10
2.3 The Atomics International Program . . . . .	10
2.4 State of the Art Survey . . . . .	11
2.5 Survey Findings . . . . .	11
2.6 Continued Need for Remote Welding Development . . . . .	13
3. THE SELECTION OF A SYSTEM TO BE DEVELOPED FOR REMOTE MAINTENANCE . . . . .	15
3.1 "Orbital-Vehicle" System Advantages . . . . .	15
3.2 Future System Expansion and Modification Plans . . . . .	15
3.2.1 Development of Additional Modules . . . . .	15
3.2.2 Alternate Carriage for Seal-Weld Capability . . . . .	16
3.2.3 Development of Special Features for Nuclear System Applications . . . . .	16

## SECTION B

4. PRESENT PROGRAM STATUS . . . . .	17
4.1 General . . . . .	17
4.2 ORNL's Prototype Automated Remote Cutting and Welding System for 6 and 8-in. Pipes . . . . .	17
4.2.1 Carriage . . . . .	18
4.2.2 Universal Machining Head . . . . .	18

4.2.3	Universal Welding Head . . . . .	18
4.2.4	Welding Programmer and Control Unit . . . . .	25
4.2.5	Power Supply . . . . .	25
4.2.6	Equipment Modifications for Remote Work . . . . .	28
5.	MACHINING STUDIES . . . . .	28
5.1	General . . . . .	28
5.2	Equipment Evaluation . . . . .	30
5.3	Tooling . . . . .	30
5.4	Machining Feeds and Speeds . . . . .	31
5.5	Machining Techniques for Slitting and Beveling Pipes; Pipe End Preparation Requirements for Welding . . . . .	33
6.	WELDING STUDIES . . . . .	34
6.1	General . . . . .	34
6.2	Preweld Joint Cleaning . . . . .	40
6.3	Joint Fitup Tolerance . . . . .	40
6.4	Inert Shield Gas . . . . .	40
6.5	Electrode Configuration . . . . .	41
6.6	Automatic Arc Voltage Control . . . . .	41
6.7	Pre-Weld Positioning . . . . .	42
6.8	Root Pass . . . . .	43
6.9	Fill Passes . . . . .	43
6.10	Repair Welding . . . . .	43
7.	SPECIAL ORBITAL EQUIPMENT MAINTENANCE REQUIREMENTS . . . . .	44
7.1	Carriage . . . . .	44
7.1.1	Drive Rollers . . . . .	44
7.1.2	Idlers . . . . .	44
7.2	Electrical Items . . . . .	44
7.3	Milling Head . . . . .	44
7.4	Welding Head . . . . .	45
7.5	General . . . . .	45

## SECTION C

8.	PROGRAM PROPOSAL: DEVELOPMENT OF REMOTE CUTTING, WELDING AND INSPECTION EQUIPMENT FOR REACTOR SYSTEM MAINTENANCE . . . . .	46
8.1	Overall Requirements for Remote Cut/Weld Maintenance . . . . .	46

8.2 A Long-Range, Three-Phase Development Program for  
Pipe and Vessel Maintenance. . . . . 47

8.2.1 Phase I, The General Program. . . . . 47

8.2.2 Phase II, The Pipe Joint Program. . . . . 48

8.2.3 Phase III, The Vessel Closure Program . . . . . 48

—

.

.

.

.

—

.

FEASIBILITY STUDY OF REMOTE CUTTING AND WELDING  
FOR NUCLEAR PLANT MAINTENANCE

Peter P. Holz

ABSTRACT

When reactors and related systems require maintenance and repairs on highly radioactive components, there is an important need for remotely controlled equipment to remove and replace parts of the nuclear systems. Remote cutting and welding can be valuable techniques for component replacement as well as for sealing flanges and vessel closures. Welding offers very attractive advantages: joints can be made leaktight, joint configurations require less cell space than flanged joints; and the locations of joints can be changed comparatively easily, if necessary.

In seeking equipment which could be adapted to remotely controlled operation for reactor maintenance, ORNL selected the Air Force "orbital vehicle" cut-and-weld system as currently being most promising for further development to meet nuclear system requirements. The concept of an orbital vehicle equipment system for automated pipe work originated in 1964 at the Rocket Propulsion Laboratory of the Air Force Systems Command at Edwards Air Force Base. The development of this system was performed in conjunction with North American Rockwell Corporation, Los Angeles Division, who designed, built and tested initial models. ORNL has started to modify and adapt the orbital design for completely remote work applications.

The orbital system includes a carriage, interchangeable modules for machining or tungsten-arc welding, a weld programmer, and a conventional power supply. The working unit is quite compact, about 4 in. thick in radial dimension x 10 1/2 in. long, designed to be clamped around a pipe.

To date, we have completed the detailed drawings for fabrication of the prototype orbital system and have procured all the components for initial non-nuclear tests of the equipment. We have demonstrated the following operations by remote control methods that were generally satisfactory: clamping of the carriage on the pipe, cutting and beveling with one orbital head, changing heads, and performing filler pass welding operations. We noted that nearly perfect pipe joint preparation and alignment were required to achieve acceptable root pass welding without the addition of weld inserts. These requirements were the most difficult to meet with the orbital equipment, and root pass welding gave the most trouble. However, an alternate method of root pass

welding gave good results when joining surfaces were machined to provide extra metal on one inside pipe edge and were given a fusion welding without filler wire on the root pass. These weldments showed full penetration and excellent, even bead shape all the way around the pipe. In all cases, the subsequent filler passes were made easily and were of good quality. Since welding variables such as travel speed, current, wire feed rate, arc voltage, and arc control voltage all affect weld quality, it was observed during the tests that weld defects could often be detected as they occurred by noting the pips on recorder chart traces.

The report describes factors involved in radioactive system maintenance, summarizes some previous work on remote maintenance development, and explains how the automated orbital cutting and welding machinery system may overcome problems that have been encountered in nuclear repair work. Progress of the feasibility study to date is summarized, including descriptions of the prototype equipment and the results of machining and welding tests. The report describes additional requirements for development to provide fully remote operations and controls and proposes a long range program for development of a complete remote maintenance system for radioactive system equipment replacement by cutting and welding.

---

#### ACKNOWLEDGMENTS

The author acknowledges with thanks the excellent cooperation and assistance of the Permanent Tube Joint Technology Section of the Air Force Rocket Propulsion Laboratory, Air Force Systems Command, Edwards, California. The project engineer, Captain John L. Feldman, USAF, and his staff, particularly Mr. Edward H. Stein and Lt. Albert B. Spencer, USAF, all have done an outstanding job in supplying requested technical information and data. C. Bruce Deering of the AEC's Oak Ridge Operations Site Office provided liaison between AEC and the Air Force. Carl M. Smith, Jr., gave invaluable day to day assistance with equipment design, development, shakedown and checkout, and William A. Bird and Robert L. Moore gave important help with trouble-shooting and refining of the electronics and instrumentation. E. L. Armstrong, W. F. Cartwright, T. Ray Housley, Dunlap Scott, G. M. Slaughter, Irving Spiewak, T. K. Walters, and L. C. Williams provided valuable guidance and support. Special thanks also to W. E. Thompson for his assistance in editing this report, and to others, unlisted for brevity, who contributed in many ways.



## SECTION A

### 1. MAINTENANCE PHILOSOPHY

#### 1.1 Introduction

In the design, development, and testing of molten salt reactors at the Oak Ridge National Laboratory, the need for remote welding equipment was encountered. However, the development of reactor designs which include provisions for maintenance by remote welding logically requires that a welding process be proven feasible before the design studies are completed. Similarly, the capability for remote welding must be fully developed before a large reactor is designed on the basis of maintenance methods which require remote welding. The potential of remote welding for saving time in replacing reactor system components and for producing more reliable joints and seals was recognized, and feasibility studies of remote welding were started as part of the Molten Salt Reactor Program. From discussions of remote maintenance with the designers, builders, and operators of other reactors, it has become clear that the special welding equipment and techniques that have been devised on many occasions for specific repair or replacement jobs are not generally applicable. There is strong interest in a portable, remotely controlled welding system that would be generally applicable in reactor maintenance and repair work. A reliable, automated system to produce high-quality welds, even without remote controls, would be welcomed by the reactor builders, who report considerable difficulty in obtaining qualified welders and in achieving acceptable weld quality on field work at the construction site. Use of automated systems for construction welding would also give confidence and experience which would help the application of remotely controlled units in maintenance and repair work.

The problems of maintenance and repair on reactor systems after operation has built up the radiation levels are important and widespread--no reactor is immune. The need for remote welding equipment has been recognized by reactor designers, builders and operators; but, to date there is no remote welder that can be used for general pipe and seal welding applications, although special purpose devices have been employed for some reactor maintenance jobs.

Automatic welding equipment is being used today for many applications. Some of the automatic welding methods and equipment seem well suited to development for remote welding. In particular, an automated pipe-welding apparatus developed by North American Aviation for the Air Force showed promise for remote control applications in nuclear reactor systems.

In all reactor systems maintenance must be performed by some method whenever the need arises. If it could be accomplished with reliability at reasonable cost, completely remote maintenance would be preferred, because, it reduces personnel radiation exposures and simplifies the problems of decontamination prior to undertaking the maintenance operations. Remote welding offers great promise for general application in

that almost any part of a reactor system which might fail can be cut out and replaced if equipment is available for remote cutting and rewelding.

With first-of-a-kind reactors, it is necessary to test the designs using mock-ups of the more complicated systems and components. If, at this stage, the ability to perform remote maintenance can be tested on the mock-ups, the final design can be demonstrated to be functionally sound and capable of being maintained. The satisfactory performance of remote handling devices and techniques can be proved in mock-up tests, giving increased confidence in their reliability and providing training in maintenance techniques which will reduce downtime.

It is recognized that provisions for remote control removal and replacement of all components of a reactor system would be prohibitively expensive. In practice, therefore, the degree of ease provided to accomplish remote maintenance depends upon the anticipated frequency of maintenance on each component. A reactor vessel designed for a 30-year maintenance-free life will hopefully require no remote maintenance equipment. Pumps, valves, cold traps and other items which fail or need maintenance more frequently may justify rather elaborate remote control devices to speed up and make more reliable the operations of maintenance and replacement. If portable remote welding equipment can be proved workable, even already-built reactors not designed for remote maintenance may receive many of the benefits.

In October 1968, a draft of the "Code for Inservice Inspection of Nuclear Reactor Coolant Systems" was developed under the sponsorship of the American Society of Mechanical Engineers and the AEC. The Committee which prepared the draft of the Code noted that "recognition was given to the problems of examining radioactive areas where human access is impossible, and provisions are incorporated in the Code for the examination of such areas by remote means which are not yet fully developed." The Code clearly shows that welds are considered to be of prime importance among the areas requiring inspection. The general need for remote cutting and welding equipment which can repair flaws disclosed by the inspections is given emphasis by the criteria spelled out in the Code.

## 1.2 Approaches to Maintenance

Components which failed or developed trouble after radioactivity levels had built up have been repaired in many reactors. The methods employed in making repairs have invariably been make-shift in terms of equipment, techniques and procedures because standard equipment for remote maintenance is not available. There seem to have been two general approaches to reactor system maintenance: Where possible, flooding with water has been used to provide radiation shielding while still allowing visibility and mobility. In other cases portable or temporary shields, usually lead, have been employed to protect workers who must enter radiation fields. The methods have been combined at times.

### 1.2.1 Some Examples of Maintenance Methods

The Gas-Cooled Reactor Experiment in Idaho was flooded with water and repaired by divers working underwater to break and remake flange joints in replacing sections of two cooling water lines. Two divers worked 112 hours in making the repairs. No welding was involved. Radiation exposures were about 400 to 600 mr for the workers' bodies and about 50% more for their hands.<sup>1</sup>

Divers were also used in making repairs to the core support plate and the fuel channels of the Big Rock Point boiling water reactor. This work involved bolting pieces in place and not welding. Later, repair work on the thermal shield of the same reactor was performed underwater with long-handled tools and television viewing. At this time, the radiation levels had increased, during additional reactor operation, to the point where the use of divers again could not be considered. The underwater maintenance operations involved some machining work and included seal welding of all nuts and keepers.<sup>2,3</sup>

The Dresden-1 boiling water reactor experienced a number of cracks in welds which were repaired by direct work from behind a lead shield with a lead pipe to protect the worker's hand and arm. By having just a small hole in the lead pipe to allow movement of the welding head, workers were protected as much as possible during their working time inside the radiation zone. Even so, more than 50 welders had to be called upon so that no person would have to work in the radiation field long enough to receive an overexposure to radiation.<sup>4,5</sup>

On the BONUS boiling water, nuclear superheat reactor, Oak Ridge supplied a welder to work on the superheater steam piping. With some water shielding and a lead box for the worker, welds were made directly on the tubes.<sup>6</sup>

The boiling water reactor of the Oyster Creek Nuclear Power Plant was found to have cracks in field welds on the tubes for the control rod drives.<sup>7</sup> Fortunately the cracks were discovered before the reactor had been operated. Nevertheless a one-year delay resulted from the time required to diagnose the problem and its extent and to prepare to make the necessary repairs, even though remote control operations were not necessary. Similar cracks have been found, also before operations started, in the boiling water reactors for the Nine-Mile Point Power Plant of Niagara Mohawk and the Tarapur Nuclear Power Station in India. Had these cracks not been discovered before operations started, the job of fixing them would have involved long shut-downs.

For work on the calandria of the Sodium Graphite Reactor, Atomic International developed a remotely controlled cutting and welding system. Bench tests were promising for specialized welding on the SGR calandria, which the remote welder was specifically designed to fit; however, the reactor project was terminated and the equipment was never used in a radiation field.<sup>8</sup>

A remote welder was rented from Atomics International to make weld repairs on the tube-to-tube sheet welds of the steam generator of the Fermi sodium-cooled, fast reactor. This machine was used to make 1200 welds, taking 45 sec per tube.<sup>9,10</sup>

The Dounreay Fast Reactor developed a small leak in a sodium coolant outlet pipe near the reactor vessel. The reactor was down for one year to locate and repair the leak.<sup>11</sup> The cutting of the leaking section was done directly using a lead shield, but a special remote welding gadget was designed and built for rewelding the pipe.<sup>12,13</sup> Welders received their three months' radiation exposure limit in six hours' working time. Problems were encountered in obtaining skilled welders to do the job.

The Hallam sodium-graphite reactor used an automated remotely controlled welder inside a hot cell to seal weld the containers for spent fuel elements. Manipulators are used to operate the remote welding apparatus.<sup>14</sup>

### 1.3 Remote Maintenance Considerations

In general, radioactive reactor system components are interconnected with large pipes which must be disconnected and rejoined when components are replaced. Also large vessel access openings must be opened for inspection and replacement of internals and then resealed. Flanges with mechanical seals and remote welding are two possible methods of rejoining pipe or closing vessel openings. Some of the considerations which affect the choice of the approach are given below. More detailed discussions on weld joint maintenance are included in Section B.

#### 1.3.1 Equipment Location for Maintenance

To be best suited for remote maintenance, reactor components and piping should be physically located so as to permit access from above for removal and replacement operations. This, however, imposes rather severe restrictions on layout since it virtually eliminates stacking of equipment within a cell. Therefore, if cell space savings from stacking of components are to be achieved, consideration must be given to the predicted frequency of maintenance on any specific assembly of piping and components so that the most frequently worked-on assemblies will be placed in the most readily accessible locations. The designer thus provides unrestricted overhead access on a first priority basis for the components needing maintenance on a regularly scheduled basis, and then provides access for anticipated "trouble area" work. When this has been done, remote methods can be employed most effectively to reduce the cost and increase the reliability of maintenance operations.

#### 1.3.2 Mechanical Joint Considerations

- a. All reactor system joints must be leak-tight to prevent the outleakage of coolant and radioactivity or the in-leakage of external gases which might contaminate the contained fluid. Furthermore, some of the reactor coolants become very corrosive

when exposed to atmospheric oxygen or moisture. An inert gas buffer between the gas or liquid in the pipes and the atmosphere is sometimes employed, at slightly higher pressure, to assure that mechanical joints are effectively leak tight. Since this seal is so important for the integrity of the system, the equipment which maintains the overpressure must be extra reliable.

- b. Any mechanical seal requires large forces to keep the sealing surfaces in contact during all excursions of system temperature and pressure. As an example, the solid metal seals which use rings in grooves require a certain minimum force to maintain the seal. Additional strength is needed to resist the axial and bending stresses transmitted through the pipe. There are acceptable clamping and bolting methods for providing this strength where the joint is not subjected to large thermal stresses which deform the ring seal, or to high temperatures which might anneal the clamps. Unfortunately, the higher temperatures (1000 to 1500°F) of advanced reactor systems make satisfactory bolting or clamping a difficult problem.
- c. In high-radiation fields, the flanged joints must be operated and maintained by remote means. There are problems of operating bolts or bulky clamps by remote control, of removing the component without damaging the joint, inspecting and cleaning the precision seal surfaces, installing the polished ring undamaged, installing the new component, aligning the joint, remaking the clamp, and leak checking the seal. Some of these problems would be encountered in remote welding, also. When a mechanical joint leaks, the maintenance crew has a choice of repair by tightening the joint or by replacing the ring with one plated with a soft metal such as gold.
- d. For replacement by welding or by flanged connections, all joints connecting the component into the system must be in proper alignment before bolting or clamping. Warpage during the thermal cycling that occurs in any plant may require awkward placement of the joint and a complicated installation sequence as the new component is brought into the final position. The changes in previously established locations will require careful measurement by remote means to determine the exact location of the in-cell joint so that adjustments can be made to align the new component. A mechanical joint does not permit much margin for error in alignment and fitting after the component is in the cell, whereas with a welded joint, in-cell machining of mating surfaces could be used to correct certain misalignments.

### 1.3.3 Welded Joint Closure Considerations

- a. In joining pipes, welding can be used either to provide a full strength, full penetration welded joint, or to provide a seal around a gasketed flange joint. Most full-strength weld closures require multi-pass welds which are difficult to make.

Yet these all-welded joints, to be leaktight, must be metallurgically sound. Joint alignment, purge gas, weld arc, and weld metal feed variables will affect bead shapes and weld quality. These variables are discussed in more detail in Section B.

- b. Numerous problems that are associated with the inspection of welds are not encountered or are less severe with flanged joints. It is an accepted fact that welds must be thoroughly and properly inspected to assure joint integrity. Nuclear plant weld quality requirements exceed the specifications for conventional steam power plants. Weld inspection techniques must work in high radiation backgrounds which make normal radiography impossible. Inspection equipment manipulations must be controllable from remote locations and viewing is possible only by indirect means. Inspecting with magnetic fields, or charged particle beams, generally is unsuitable to nuclear plant materials and/or conditions. Ultrasonic inspection has shown promise, although much more must be done to adapt ultrasonic techniques to remote work. The Pacific Northwest Laboratory has proposed an ultrasonic inspection development program for the FFTF. Another ultrasonic inspection development program is being sponsored by industry through the Edison Electric Institute, and is being conducted under subcontract at the Southwest Research Institute, Houston, Texas.<sup>15</sup>
- c. Preweld joint preparation required for remote welding involves accurate, axially square precutting of the joint, matching of the respective inside and outside diameters along with precision alignment of the pipe stub to be welded, and possible rebeveling to obtain acceptable alignment of mating joint members. It is imperative that a thorough cleaning of the pipe interior at the joint area precede all work, and that utmost care be taken to completely remove all weld preparation cuttings which might damage pumps, valves, etc., if allowed to remain in the system and circulate with the fluid. Wire brushing and solvent cleaning may also be required to prepare the weld area.
- d. Repairs to faulty reweld joints are equally difficult. The previously described inspection and cleaning requirements apply to rewelding also.

#### REFERENCES

1. Divers Repair GCRE Vessel, Nucleonics, p. 78, May 1961.
2. J. I. Riesland and E. A. Gustafson (GE - San Jose), Work Performed on Fuel Channels and the Core Support Plate at Big Rock Point Nuclear Power Plant, Conference on Reactor Operating Experience, July 28-29, 1965, Supplement to Vol. 8, Transactions of the American Nuclear Society, 1965.

3. L. M. Hausler and R. L. Hauter (Consumers Power), In-Vessel Modifications of Irradiated Reactor Internals at Big Rock Point, Conference on Reactor Operating Experience, July 28-29, 1965, Supplement to Vol. 8, Transactions of the American Nuclear Society, 1965.
4. R. H. Holyoak (Commonwealth Edison) The 1967 In-Service Inspection of Dresden 1 Nuclear Power Plant, Transactions of the American Nuclear Society, Vol. 10, p. 635, November 1967.
5. Clifford Zitek, Personal communication during a visit to ORNL, 1968.
6. Everett Rogers (Oak Ridge Y-12 Plant) Personal communication; Rogers did the welding for the BONUS repairs, 1968.
7. United States Atomic Energy Commission Licensing Docket No. 50-219, Amendment 35, Final Report on Reactor Vessel Repair Program, March 1968.
8. L. Newcomb, Calandria Remote Maintenance Tool Development, Atomic International Report NAA-SR-11202, April 1966.
9. J. F. McCarthy, Compilation of Current Technical Experience at the Enrico Fermi Atomic Power Plant, Monthly Report No. 7 to the U. S. Atomic Energy Commission, February 1967.
10. L. T. Bogarty, Modular Steam Generator Fabrication, Atomic International Report NAA-SR-11739, February 1966.
11. Dounreay Developments: Good progress on PFR; DFR is back at full power, Nuclear Engineering, p. 633, August 1968.
12. Memo to Myron B. Kratzer, Assistant General Manager International Activities, U. S. AEC, from Carl R. Malmstrom, AEC Scientific Representative, U. S. Embassy, London, England; Trip Report to Dounreay, February 20, 1968.
13. R. R. Matthews and K. J. Henry, Dounreay Experimental Reactor Establishment, TRG Report 1854R, Nuclear Engineering, Vol. 13, No. 149, pp. 840-844, October 1968.
14. S. Berger et al., Six Element Irradiated Fuel Shipping Cask, Atomic International Report NAA-SR-12547, Appendix 10, pages 310-319, November 1967.
15. Grady Whitman, Welding Research Council, Pressure Vessel Research Committee, Personal communication, September 1968.

## 2. HISTORY OF REMOTE WELDING

### 2.1 Background

Attempts to develop automated remote welding systems for use in nuclear work have been pursued, off and on, for more than ten years. Most of the efforts, including some at ORNL, were on a small scale. Limited findings from the earliest remote welding work formed the background for the Pennsylvania Advanced Reactor (PAR) maintenance welding development program.

### 2.2 The Pennsylvania Advanced Reactor Program

The Pennsylvania Advanced Reactor (PAR) was planned in the mid 1950's to use a circulating aqueous slurry fuel pressurized to 1000 psi. The high-pressure system required extra care in fabrication to avoid leaks and also placed a premium on being able to repair leaks that developed. It was recognized that circulating fuel would increase the radiation levels in the reactor system areas and would make completely remote maintenance a necessity.

In planning the PAR,<sup>16</sup> Westinghouse specified remote welding as the mandatory method for performing maintenance on the reactor plant. Although certain phases of the development program were completed, the PAR project was terminated before the remote welding techniques were ever demonstrated in an operating reactor system. A tube-plugging procedure had been devised to use remote welding in maintaining the system generator; the plug was to be inserted into the tube and welded to the tube sheet. A flange on the plug provided the metal for the weld and also covered the leak path between the tube and tube sheet.

The tungsten-arc welding process was selected by the PAR group for remotely butt welding joints in the fixed piping. To simplify equipment, it was decided that each remote welding head would be designed to fit no more than two pipe sizes. A contract had been negotiated with a manufacturer of welding equipment to improve an existing machine to permit continuous rotation welding with 100 percent arc time, with automatic and complete control, and with completely dependable weld quality. A prototype model of the machine with fully automatic controls showed promise in bench tests, but it was not equipped for remote work. Also, the machine needed further development to be sufficiently reliable for remote maintenance work.

### 2.3 The Atomics International Program

During the 1960's, Atomics International, now a Division of North American Rockwell Corporation, developed and perfected a number of automated welding systems. Some were remotely controlled for work in connection with AEC's sodium-cooled reactors; others were automated, but not remotely controlled, for space program requirements and for the shop fabrication of heat exchangers and tubing systems for civilian power reactors. While much of their work was concentrated on production



welding operations in shop fabrication, AI also developed advanced remote welding technology for specific applications, such as internal tube welding for steam generator fabrication, deep-hole welding for work on the calandria of the sodium-graphite reactor, and seal welding the containers for nuclear fuel canning.

Internal welding equipment makes tube-to-tube-sheet welds and also tube-to-tube welds, with the welding head located inside the tube. AI's automatically programmed system was developed for fabrication of high-temperature, high-pressure modular steam generator joints for the Sodium Component Test Installation. It did not operate by remote control.<sup>10</sup>

Deep-hole welding equipment was developed as an extension of internal welding technology to permit remote removal and replacement of process tube and associated graphite log assemblies from the Sodium Graphite Reactor Calandria Core. Blind cutting and TIG rewelding were accomplished by remote control equipment reaching as far as 40 ft through a 4-in.-inside-diameter tube.<sup>8</sup>

The seal welding of spent fuel in cans was performed in a manipulator cell at Hallam.<sup>14</sup>

#### 2.4 State of the Art Survey

Seeking information on remote maintenance equipment and techniques that might be applicable to molten salt reactors, ORNL conducted a survey early in 1968 to determine the state of the art. Emphasis was placed on remote welding, which was considered to be of greatest interest for molten salt reactor systems. Specific inquiries were made about all development and applications of remotely operated, automated equipment for reactor system maintenance and repairs. Equipment and techniques for cutting, beveling, welding and testing weld quality were particularly sought out.<sup>17</sup> We specifically looked for a utility machine that would do cutting, beveling and welding with one set up.

#### 2.5 Survey Findings

The survey disclosed a few specially designed, automated welding assemblies which were remotely controlled by manipulators. Argonne National Laboratory has performed welding on the complex experimental equipment inside a hot cell in this way; at Hallam, Nebraska, Atomics International has a manipulator cell equipped for making seal welds on containers for spent fuel elements; Aerojet Corporation at Azusa, California, used a similar setup for canning radioisotope sources. The Electric Boat Company at Groton, Connecticut, and the Liquid Carbonics Company of Chicago, both Divisions of General Dynamics, developed an automated welding system for use on shop fabrication work, without remote controls. In the production of components for submarines, welding is being done increasingly by the automated welding systems (TIG, with weld inserts for root pass). The Navy claims time and dollar savings along with superior weld quality.<sup>17</sup> It was pointed out by a number of the people interviewed that, at

present, no one markets automated welding machinery for field use, although there are many applications where automated equipment would be most valuable.

The following comments from Mr. Richard H. Freyburg, Assistant Manager of Operations for Consolidated Edison Company of New York, point out some of the reasons why reactor builders have keen interest in automated welding equipment, even without remote controls:

"Industry can not take trained nuclear welders from site to site for reactor construction because union restrictions usually permit only one company welder for every 12 welders supplied by the local union. The training program for nuclear welders is tedious; we're lucky to get 60% of the new men qualified. Many of those passing the nuclear welding qualification tests are not well suited for construction work in other respects. If we had reliable, relatively simple, automated machinery for beveling and welding, we could train welders faster to operate the automated equipment and the quality of the welds would be better, with fewer rejections. In fact, automated beveling and welding machines, on construction, could be worked around the clock. We could even afford to put on an extra man to permit coffee breaks for the operators and still be well ahead. Furthermore, if our people gain confidence in the automated machinery during construction of the reactor, they will be glad to pay the price later for a more expensive, remotely operated machine for reactor maintenance work. My most urgent need is for a reliable, automated welder that reduces rejections on construction field work."<sup>18</sup>

Maintenance and associated program and control equipment for automated welding have not yet been simplified and made rugged to the point where such systems economically challenge manual welding for field work. Our survey, however, revealed two automated systems which, with modifications, might be useful for remote nuclear work. One is an "orbital vehicle combination cut, bevel, weld carriage concept" developed and tested by North American Aviation, Los Angeles, a Division of North American Rockwell Corporation, under Air Force Contract; the other is a combination of either Wachs (E. H. Wachs Company, Wheeling, Illinois) or Fein (Prescott Tool Company, West Boylston, Massachusetts) pipe cutters for cutting, plus specially automated Dyna-Surge APW Series Systems (Liquid Carbonic Division, General Dynamics Corporation, Chicago, Illinois) for welding. The Dyna-Surge system technology originated at the Electric Boat Division of the General Dynamics Corporation and was used for their production welding in submarine work. Dyna-Surge weld head assemblies employ a stationary cylindrical track, clamped around the pipe, with a geared rotating part on which the electrode holder is mounted. Torch support and travel components are similar to equipment marketed by AB ASEA SVETSMASKINER, the Stockholm, Sweden manufacturer for special European automated weld machinery, or by Clarke, Chapman & Co., Ltd. of England. Wachs and Fein pipe cutters are commonly used in coal mining operations, in fabricating gas plant equipment, in

marine salvage work, and in production pre-weld pipe end shaping. A still experimental automatic welding machine for large size overland transmission piping only is being built by CRC-CROSE, Inc. of Houston, Texas, and is now being tried out in a full scale field test on a Coastal States Gas Producing Company pipeline in the Southwest.<sup>19</sup>

## 2.6 Continued Need for Remote Welding Development

There were two full-fledged remote welding development programs primarily associated with reactor projects, the PAR and the SGR, which were discontinued before remote welding equipment was fully developed. Other devices for remote welding have been built and used to perform specific jobs in making repairs to reactor systems.

For a number of years, ORNL has used an automated, remotely controlled welding apparatus inside a hot cell to seal radioisotope source containers. In this case the containers are small, the job is repetitive, and the remote welding equipment does not have to be moved about within the cell. In general practice, reactor fuel elements are seal welded in thin-walled containers before being placed in the shielded carrier when they are to be shipped off site. This seal weld is usually made by remotely controlled equipment in a hot cell. Other remote welding operations have been performed at various times and places using equipment specially adapted for the specific job. The state of the art seems to be that automated welding equipment has been developed to a point where it is possible to adapt commercially available equipment to the performance of specific - and, to date, fairly simple - remote welding jobs.

Although automated welding is being used increasingly in shops for a variety of applications, there are no present applications of automated welding to nuclear reactor system components being welded in the field. In the shop production of components for the nuclear power systems of submarines, automated welding is being increasingly used. Weld insert rings are used to fusion weld Naval joint root passes. The Navy reports savings in time and cost over manual welding, and claims superior weld quality, also.

Needs for remote welding equipment have become more widespread and actual applications of equipment for performing specific remote welding jobs have become more numerous. To date, however, no one has perfected a generally useful remote welding system. It is instructive to consider why the equipment has not been developed to date, even though attempts have been made, and to evaluate the prospects for success if another attempt is made. The following factors seem important:

1. Limited funding forced previous developers to resort to crude control and programming equipment and to limit their mechanical designs to oversimplified hardware items.

2. Welding and programmed control apparatus of the past lacked pulsed-arc and arc length regulation, integrated digital functional controls and solid state devices for instant response actuation. Today's remote control capabilities are much more sophisticated and adaptable to meeting welding quality specifications.
3. Miniaturized components and automated welding hardware were not available for application in the previously attempted remote welding systems. Welding equipment systems that have been developed recently for the National Aeronautics and Space Administration and for advanced aircraft applications are much superior to those that were available in the earlier attempts to adapt equipment for remotely controlled welding operations.

#### REFERENCES

16. Vol. IV, Pennsylvania Advanced Reactor Project, Layout and Maintenance, Parts 1 and 2, WCAP 1104 and 1105; Westinghouse Electric Corporation and Pennsylvania Power and Light Company, March 1959.
17. Memo from P. P. Holz to Distribution, A Preliminary Survey of Remote Cutting and Welding Techniques Under Development in the United States, MSR-68-44, February 20, 1968.
18. Richard H. Freyburg, Assistant Manager of Operations, Consolidated Edison Company of New York, Personal communication by telephone, October 1, 1968.
19. Wall Street Journal, July 8-69 issue, Page 23, Column 4, Paragraph 5.

### 3. THE SELECTION OF A SYSTEM TO BE DEVELOPED FOR REMOTE MAINTENANCE

#### 3.1 "Orbital-Vehicle" System Advantages

The Air Force's orbital vehicle machinery developed by North American-Rockwell for pipe joint-replacement maintenance offers a number of advantages for cutting and rewelding nuclear piping. A single, compact carriage propels interchangeable heads for cutting or welding. This single setup for all phases of repair work simplifies the indexing on the spot to be cut and welded and assures repetitive precision tool alignment. Equipment setup time savings also result, especially where weldment repairs might be required.

The tungsten inert gas (TIG) welding process which had been used by the Air Force in their work with orbital machinery was also chosen for initial tests at ORNL because it offers most promise of meeting nuclear weld requirements. This process has several inherent characteristics that are especially suitable for remote fixed-position welding. TIG welding is a low inertia process and is relatively slow, which makes it much easier to control and monitor for high integrity welds. The amount of molten metal at any time is relatively small, creating a quick-freezing puddle with sufficient surface tension to counteract gravity. The process thus works equally well whether the weld is going up-hill, down-hill or horizontally. The arc length of the non-consumable electrode can be maintained more easily than that of a consumable electrode. There is no flux or slag associated with the process to require special interpass cleaning, although brushing to remove the light oxide film is desirable. Filler wire is fed directly into the weld puddle. The metal does not have to be transferred into a molten state across an electric arc, an operation that sometimes results in spatter and uneven bead formations. A system with integral wire feed has the capability to complete a weld of thicker section than can be made by autogenous welding. It also is more likely to provide satisfactory crack-free weld metal of good composition, grain size and porosity. TIG equipment can be made compact and portable.

#### 3.2 Future System Expansion and Modification Plans

The overall development program for an automated cut-and-weld reactor maintenance system is divided into two parts; a system feasibility study and development phase, and future system expansions and modifications along the lines described below.

##### 3.2.1 Development of Additional Modules

The ability to change modules on the orbital vehicle carriage suggests that development and application of additional, interchangeable modular insert packages might be the easiest way of accomplishing additional functions. Since welding operations require strict cleanliness control and it is important to keep chips and dirt out of the process system, a clean-up module or attachment may be needed. Welding

requires that oxide and dye penetrant test films be removed from bead surfaces before making additional weld filler passes. A modular head could be developed to apply solvent cleaners and to drive a rotary wire brush for physically cleaning the weld. We plan to also develop additional modular heads for a welding inspection package, complete with TV camera, dial indicators, penetrant inspection devices, etc.

### 3.2.2 Alternate Carriage for Seal-Weld Capability

Present machinery is designed for work on piping only, with the capability of preparing joints for butt-welding, and of performing the welds. Investigations have been started to determine whether the existing modules along with the programmer can be used for seal welding applications. Such a system may include a substitute carriage to "walk" about a set of indexed mating contoured seal lips. Motor propulsion equipment for this alternate seal-joint carriage should be compatible with the orbital vehicle carriage drive so that it can be operated with the same controls and instrumentation. An alternate approach under consideration for vessel seal-weld closures is based on a free-swinging carriage operated from a radius linkage at the centerline of the opening.

### 3.2.3 Development of Special Features for Nuclear System Applications

A number of additional design modifications will be necessary in adapting the present Air Force machinery to provide better installation and operation capabilities for nuclear applications. These modifications will involve changes to positioning and handling attachments so that all of the equipment can be installed and operated from any available overhead access.

The Air Force design was modified somewhat before being used to fabricate a prototype unit for the ORNL feasibility studies. The ORNL prototype, like the Air Force equipment, utilizes readily-machinable, light-weight materials, generally aluminum. Reactor maintenance applications will require equipment which is rugged, is able to be decontaminated and repaired, if necessary, while being kept inside a hot cell, and is resistant to radiation and high temperatures. It should be possible to incorporate materials and to develop design modifications which will adapt the system to nuclear work without reducing the proven effectiveness of the overall system design or operations. For initial tests with the prototype, significant savings in time and money were achieved by using units that incorporate standard industrial components and materials. This approach will be continued through most of the development program. The more costly units, incorporating special materials for ease of decontamination and for resistance to radiation and to high temperatures, will only be built after present tests have shown complete suitability and performance of the design. For future machinery systems we contemplate relocating some electronic control components from their present module stations to the programmer, and possibly replacing some of the electrical sensing and control equipment in the module with fluidic systems to minimize radiation damage problems.

SECTION B

## 4. PRESENT PROGRAM STATUS

## 4.1 General

ORNL representatives visited the North American Aviation Los Angeles, California Division of North American Rockwell Corporation and the Rocket Propulsion Laboratory, U.S. Air Force Systems Command, Edwards Air Force Base, California during March 1968. At that time North American Rockwell, as Air Force contractor, had already fabricated two prototype orbital vehicle machines for cutting and welding 1- to 3-in. and 3- to 6-in. diameter tubing. Performance testing had just been started. Designs had also been completed by NAR for units to handle larger diameter pipes; 6- to 9-in., 9- to 12-in., and 12- to 16-in.

Arrangements were made for the Atomic Energy Commission to receive Air Force contractor design data. Design drawings for the 6- to 9-in. diameter orbital vehicle machinery were supplied to the AEC during April and May 1968. The Commission, in turn, relayed the information to ORNL. After detailed review, ORNL redesigned equipment to include provisions for remote installation and operation capabilities, and prepared detailed drawings and specifications for the commercial purchase of mechanical assemblies. Fabrication of the prototype unit for testing at ORNL began in August 1968 and was completed during February 1969. To save time and initial costs, arrangements were made to borrow a spare Air Force programmer to control the operation of the equipment for a limited evaluation period. A replacement programmer is being fabricated by ORNL and will be completed by September 1969.

The initial ORNL development efforts started in March 1969 and were directed toward establishing the feasibility of using remotely operated machinery that will cut, bevel, and either seal or strength-weld joints and piping for nuclear applications. Initial cutting and welding studies and tests closely followed current USAF rocket system welding technology developments.

Detailed discussions on early development findings at ORNL are reported on in the following chapters on pipe machining and welding studies. The development work to date shows that it is feasible to use automated orbital machinery for remote cutting and welding.

## 4.2 ORNL's Prototype Automated Remote Cutting and Welding System for 6 and 8-in. Pipes

The Air Force has orbital carriages for the following outside diameter ranges; 3 to 6 in., 6 to 9 in., 9 to 12 in., and 12 to 16 in. We selected the 6- to 9-in. carriage for work with 6- and 8-in. pipes. All listed carriages use the same interchangeable machining and welding heads.

The automated remote cutting and welding machinery package includes the following components shown in Fig. 1, 2, and 3: carriage, machining head, welding head, weld programmer, and welding power supply. The functions performed by these components and brief equipment summations are described in the following paragraphs.

#### 4.2.1 Carriage

The carriage provides a rigid, stable platform on which the machining head and the welding head can be mounted, indexed, and operated. Figure 4 shows the carriage with the welding head. The carriage supplies a drive mechanism to rotate the platform around the pipe circumference at preset, reproducible speeds, with controls to maintain the platform surface at a constant distance from the pipe surface so that the milling cutter depth and arc length controls will perform properly. The platform will maintain its lateral position with respect to the pipe joint while rotating about the pipe, so that when modules are changed from cutting, beveling and welding, the alignment will already be correct. The carriage geared actuator arm assemblies clamp securely to the pipe; its drive rollers are loaded by special torsion bars to maintain controlled roller clamping pressure and to compensate for pipe ovality within commercial specifications. Carriage design permits all listed tasks to be accomplished within a 4 1/2-in. radial clearance.

The carriage structure consists of two side pieces which provide a platform for the welding and machining heads, and two end supports. These supports contain the water, inert gas and electrical power connections and switches; the front support also contains the clamping device, namely worm gears which position the idle rollers through a slider crank linkage. The carriage rotates via a direct drive system from motors mounted at the two hinge points of the actuating arms within the rollers. The vulcanized high temperature, abrasion-resistant viton coating provides the necessary roller traction.

#### 4.2.2 Universal Machining Head

The machining head shown in Fig. 5, can be mounted on the carriage to cut pipe or tubing, mill the tube ends square, and bevel the edges to the desired configuration for welding. The machining head includes an outer housing, a Triac, speed-regulated, 1/4-hp air-cooled electric drive motor of the type produced for hand drills, plus the drive motor housing and cutter assemblies. Two-axis manual cutter adjustment is available. Several types of cutter blades can be installed as needed.

#### 4.2.3 Universal Welding Head

The welding head, Fig. 6, can be mounted on the carriage in place of the machining head after the cutting and beveling operations have been completed. The welding head is designed with adjustable vertical and horizontal slides to locate the electrode accurately with respect to the cut and beveled edges of the weld joint. Filler wire will be



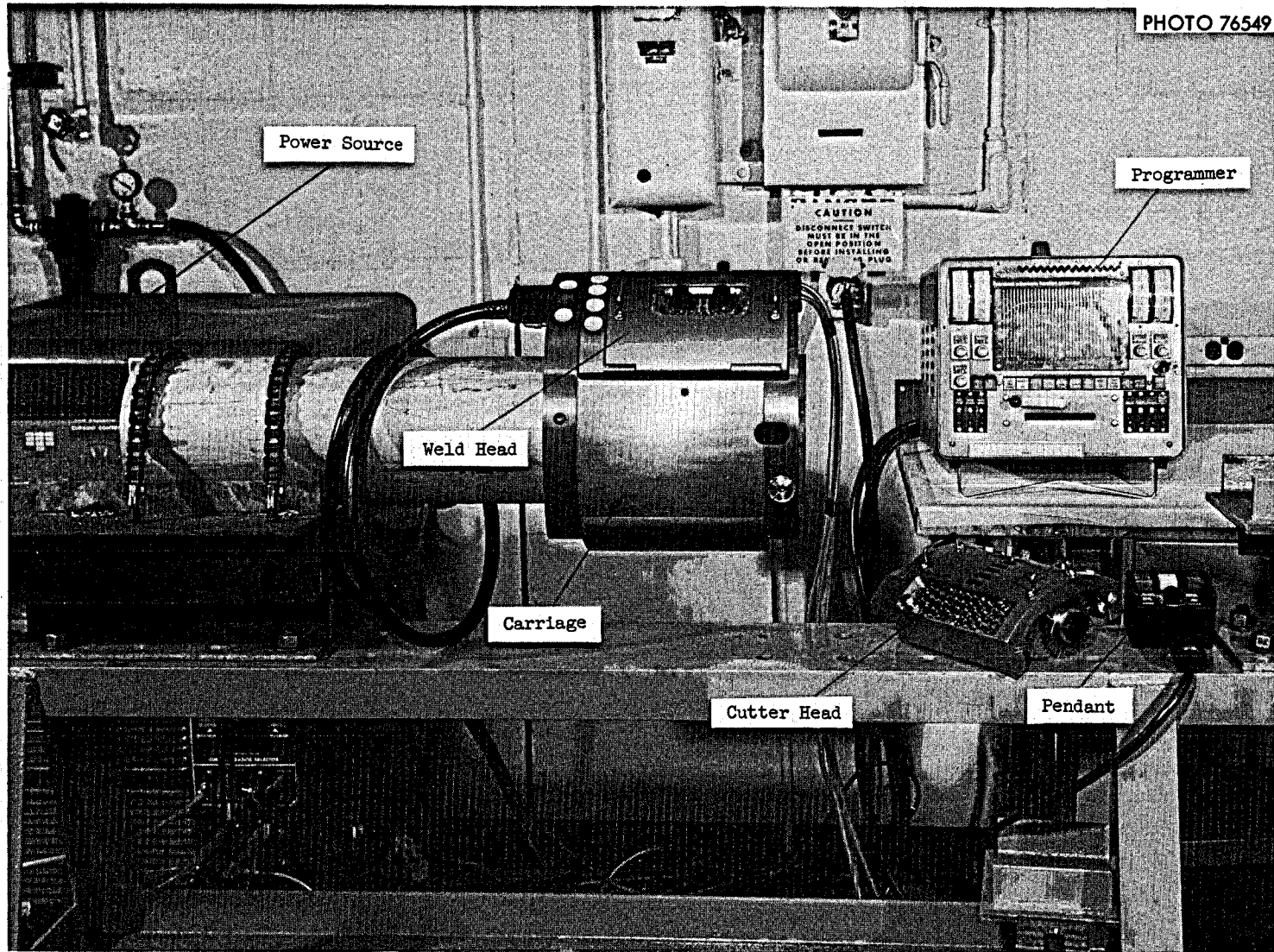

Fig. 1. Orbital Machinery Components.

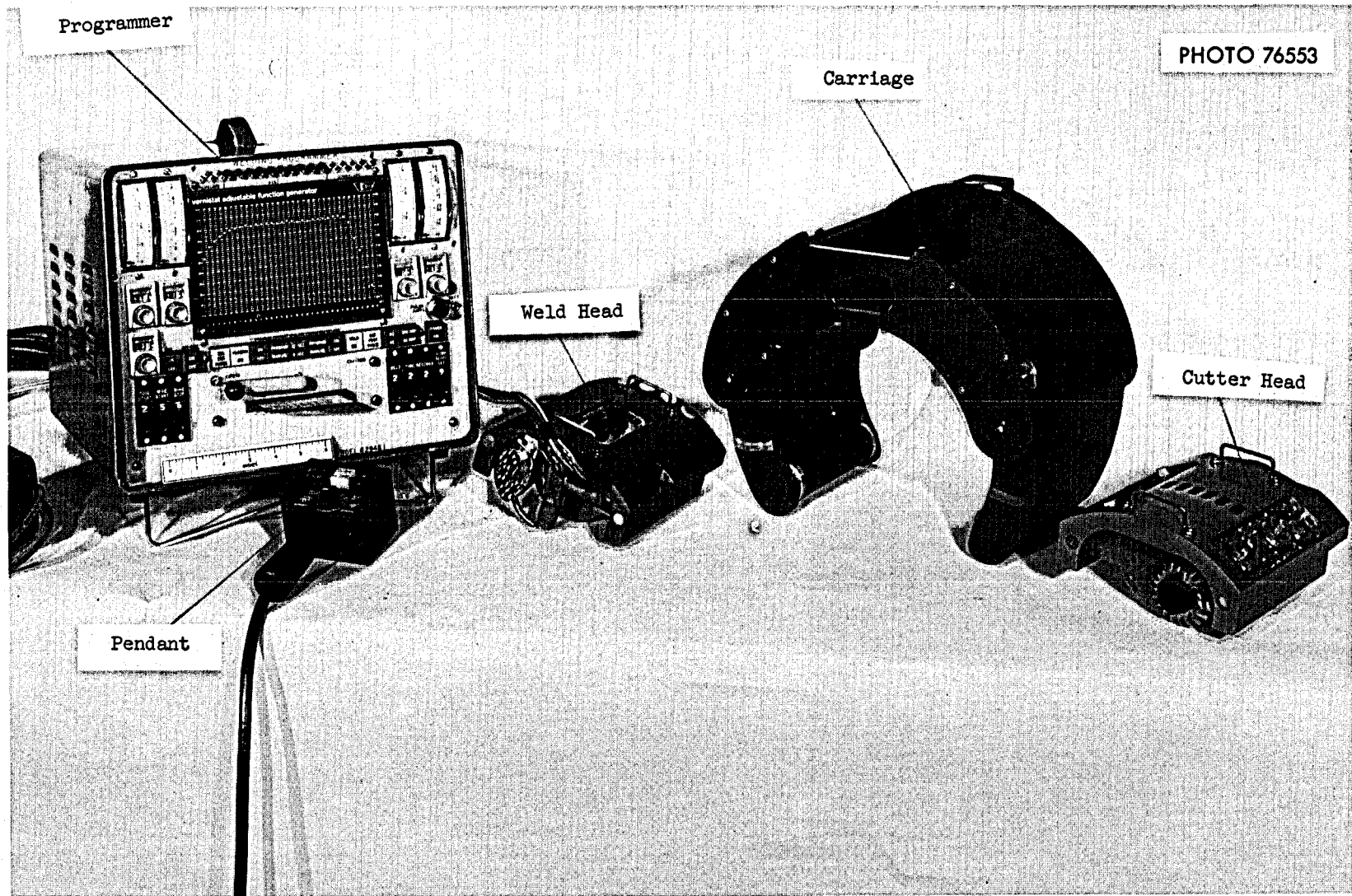

Fig. 2. Orbital Machinery Components.

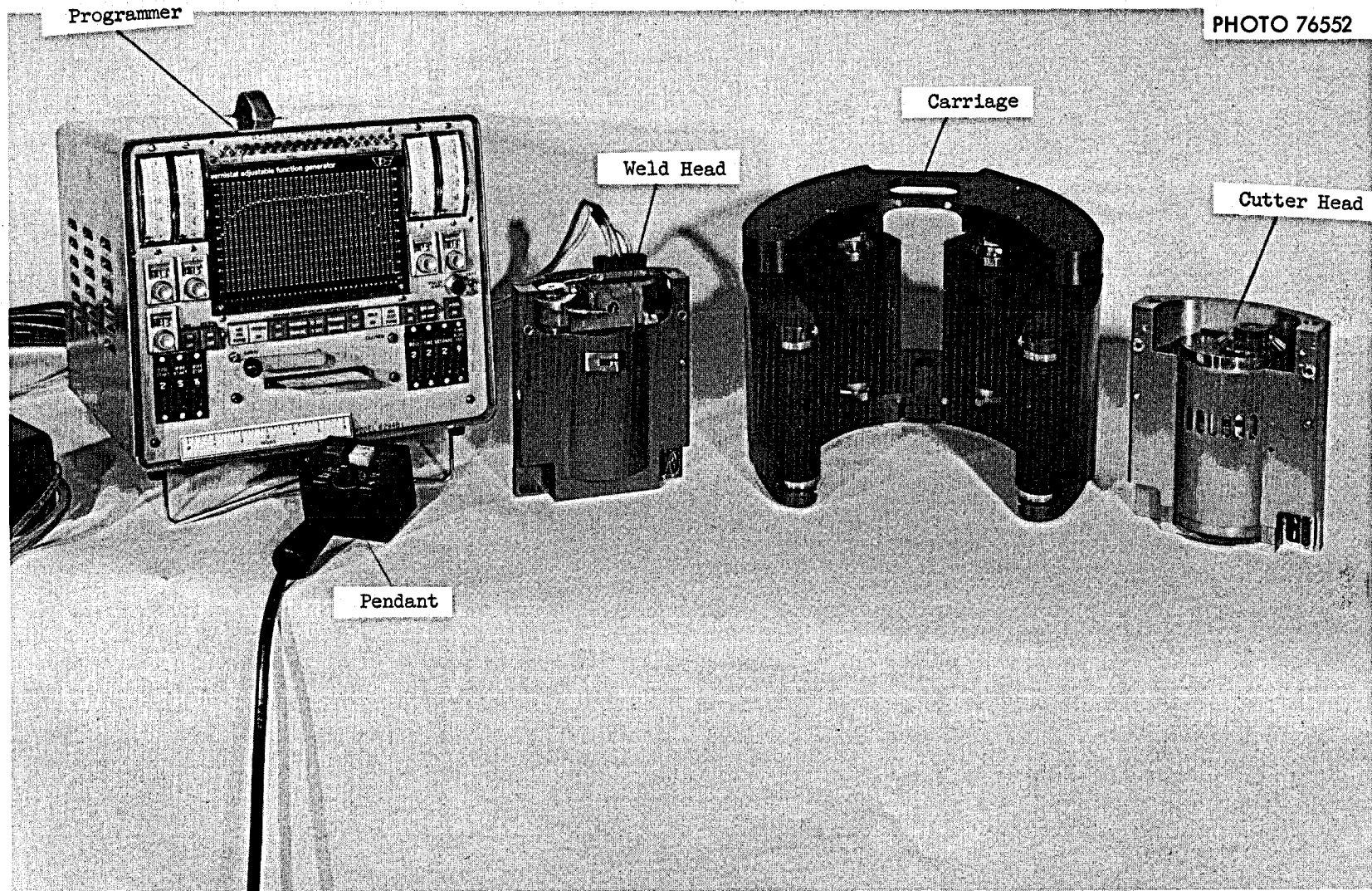

Fig. 3. Orbital Machinery Components.

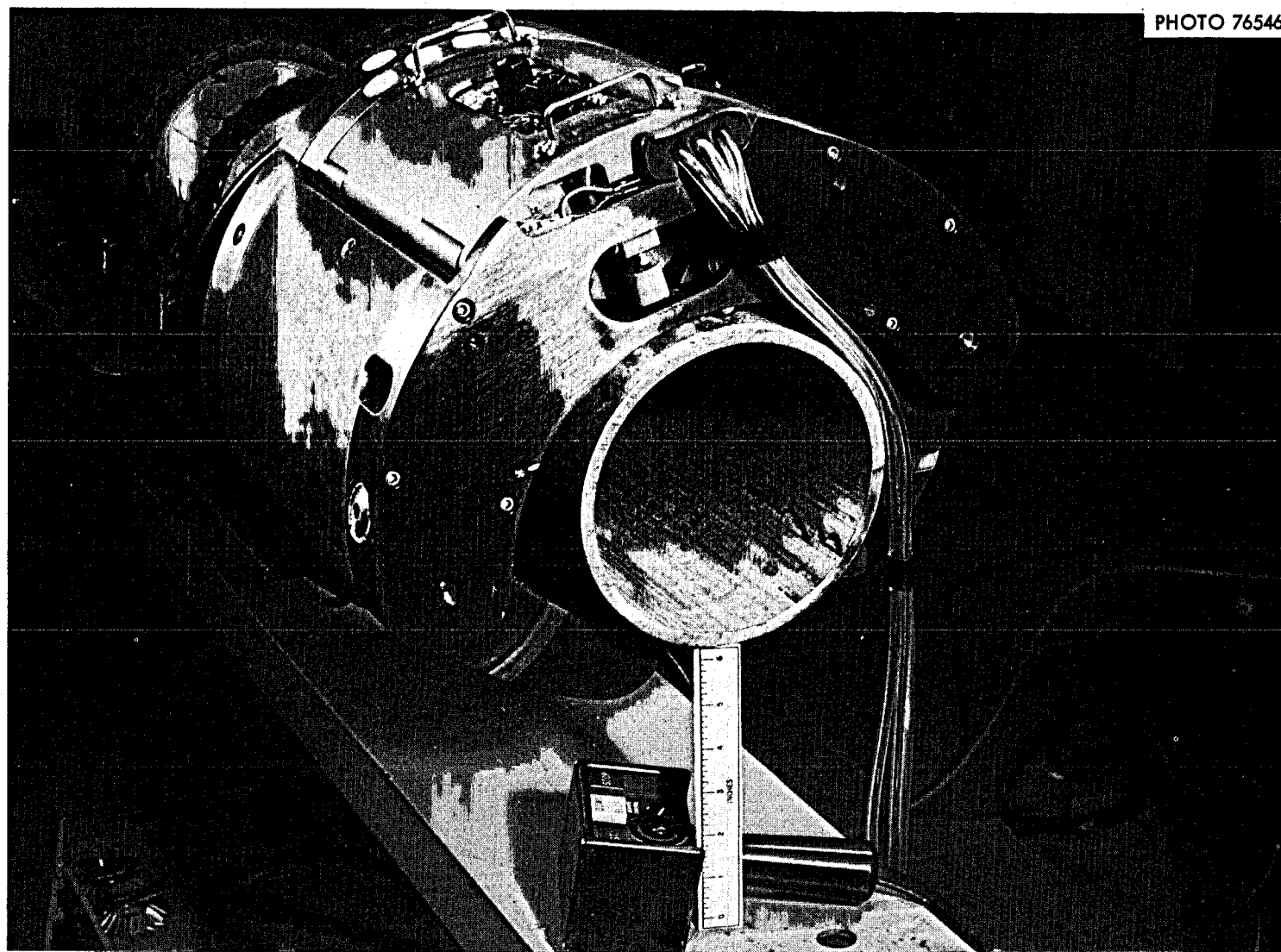

Fig. 4. Carriage (with Weld Head).

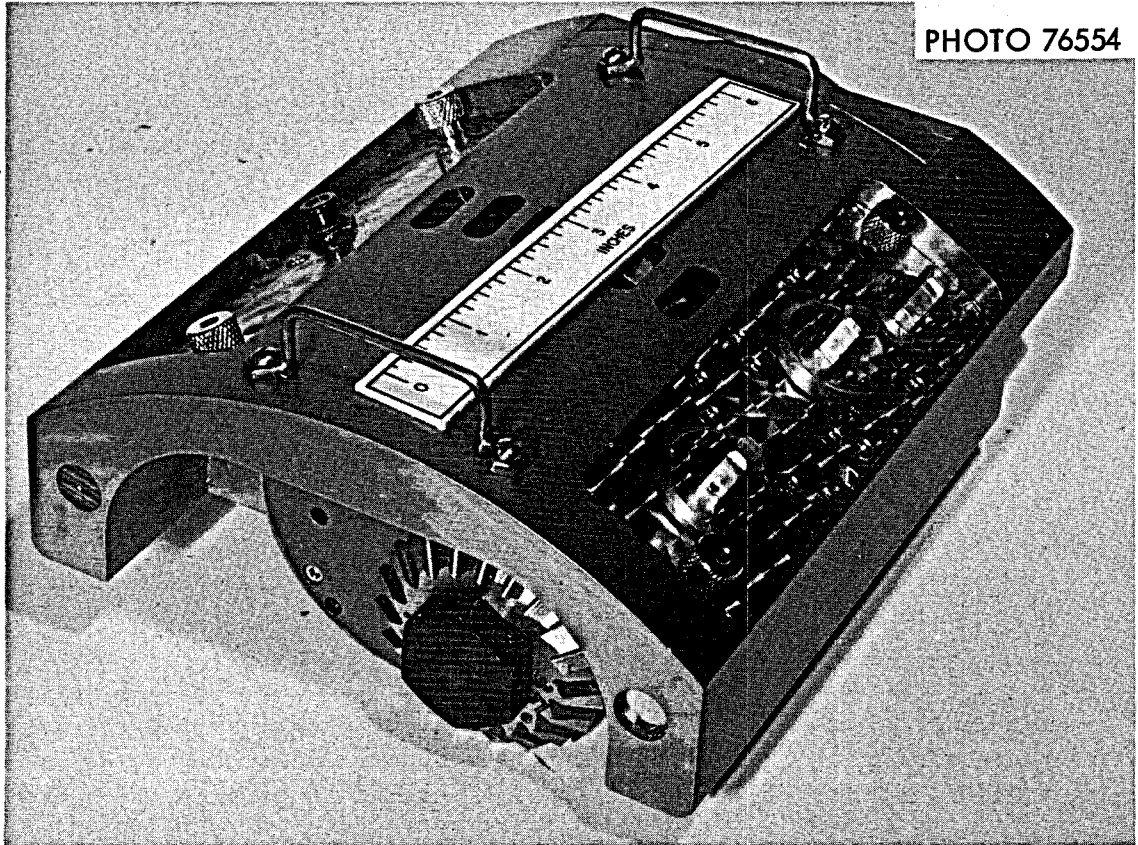

Fig. 5. Universal Machining Head.

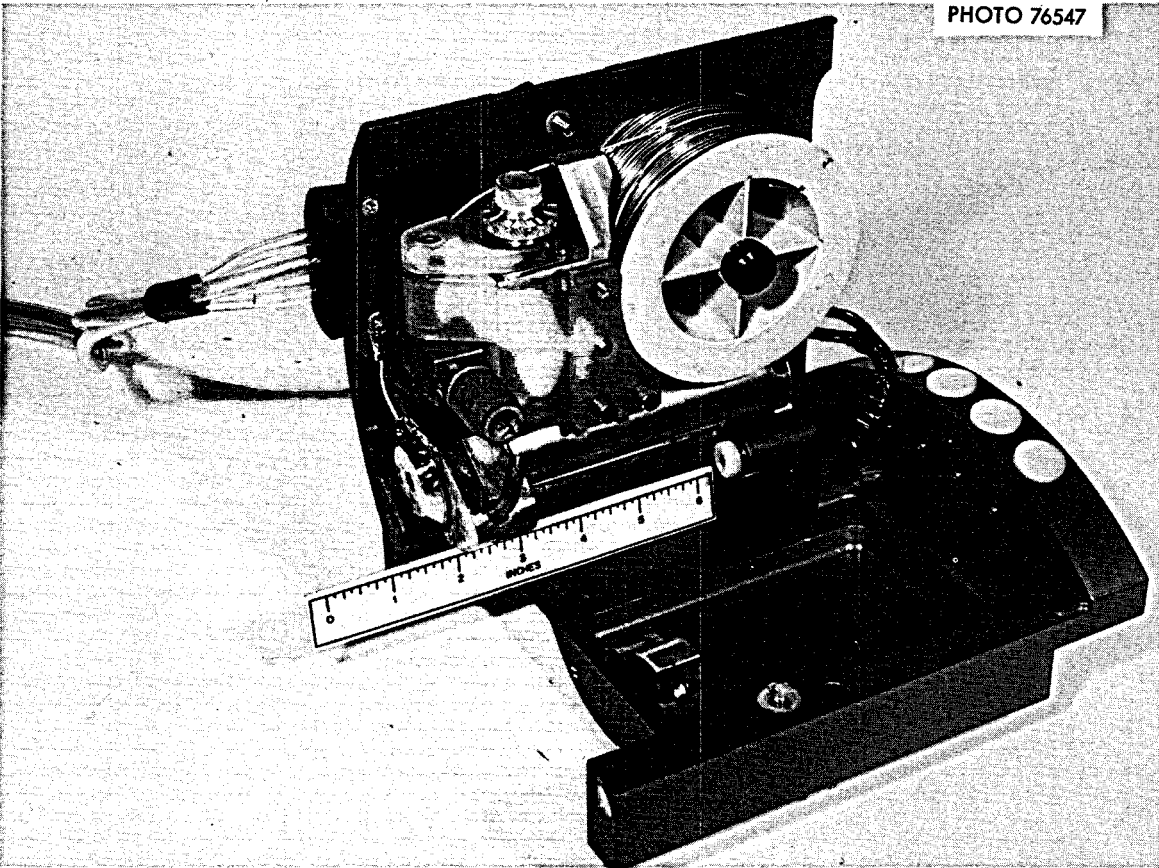

Fig. 6. Universal Welding Head.

fed automatically at the desired rate to the weld joint from a spool which stores enough wire for multiple filler weld passes. The welding head will provide an inert welding gas to the torch cup, will provide power and cooling water flow to the torch head, and will oscillate the welding electrode across the seam. It will also provide integral switches for test operating the wire feed jog, the oscillator, and inert gas flow.

#### 4.2.4 Welding Programmer and Control Unit

A pendant-housed start-stop control unit and the console-welding programmer contain the measurement recorders and control devices that provide for automated welding. The programmer, shown in Figs. 7 and 8, is designed to control and/or sequence each of the following weld variables or functions; welding current vs. time, maximum welding current, welding current pulse amperes and pulse time, current upslope time, weld time, current downslope time, welding voltage, welding tool speed and start and stop time, wire feed speed and start and stop time, arc voltage control voltage, and oscillator frequency.

The welding current and the carriage (tool) drive circuits are respectively servo-controlled. The wire feed rate can be adjusted to maintain constant electrode/weld puddle distances by using a feedback system to monitor the arc voltage and compare it to a preset, pre-determined value, and, as required, generate a correction signal. Changes in the arc gap are reflected as changes in arc voltage and these changes generate a correction signal which changes the filler wire speed to build up or to decrease the weld puddle to maintain a preset arc gap. The wire feed system also includes a transistorized motor control servo system to quantitatively regulate filler deposits in response to a tachometer feedback signal. Pipe ovality corrections are regulated by a mechanical cam device which rides the pipe and spring loads the weld head within the carriage to tend to maintain a constant tool/workpiece spacing.

Lighted buttons are provided for function indication and/or selection. Indicating meters are incorporated for tool and wire feed speed, arc voltage, and weld current. The unit is designed to provide signals which can be used with commercially-available recorders to provide permanent records. At present we use a multi-channel Sanborn 150 Recorder. The Air Force programmer, Fig. 7 also includes provisions for punched card input to provide automatic capability for program setup. This feature is especially desirable for production work. For the time being, however, primarily for economy reasons, we are not using punch card techniques in our replacement programmer.

#### 4.2.5 Power Supply

Most commercially-available welding power supply units are compatible with the programmer control circuitry and can be employed as power sources. We utilize a Lincoln Model TIG 300/300 welder with minor circuit modifications. Inductive transient suppressors and a transistorized reactor

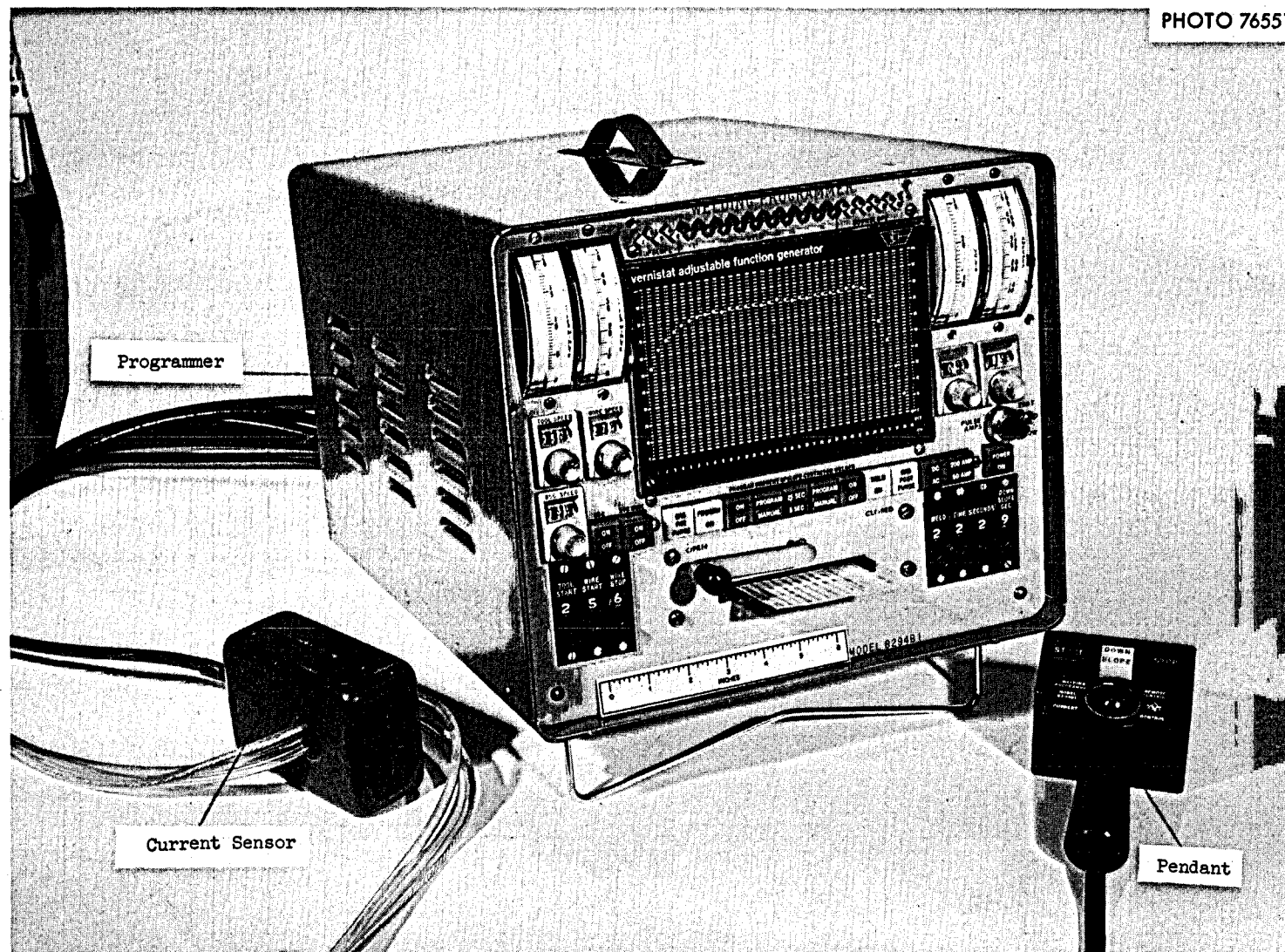

Fig. 7. Programmer, External View.



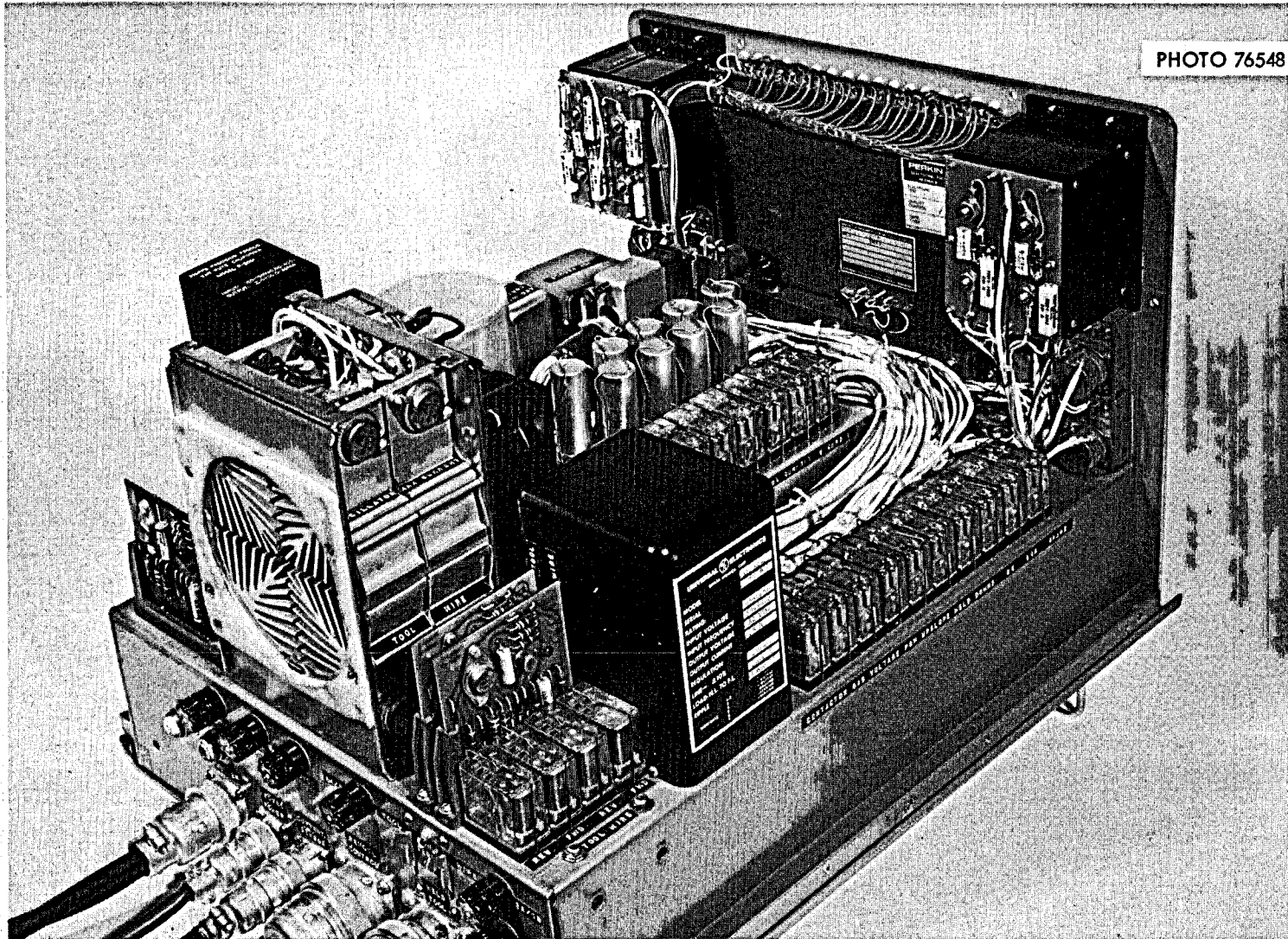

PHOTO 76548

Fig. 8. Programmer, Internal View.

control amplifier shown in Fig. 9 have been added to the welders' reactor control circuits. Welder controls for gas and water solenoid valve relays are transferred to the programmer.

#### 4.2.6 Equipment Modifications for Remote Work

ORNL's 6- to 9-in.-diameter carriage and the welding and milling insert heads incorporate a number of changes and modifications to similar Air Force equipment. Our machinery includes actuators, lifting and positioning lugs designed for remote tooling and handling. We have also eliminated from the original Air Force weld head two disconnects in the welding power supply line and the water and gas lines. Our cables are integral with the torch and route directly from the torch holder through a grommet insert in the adjacent carriage front panel. Stray RF currents and potential water leaks are eliminated. Our directly coupled torch also permits completely independent weld head (in, or out of cell) checkout and replacement. The separate power and control leads at opposite ends of the carriage work well in remote installation. Separated cords do not tangle while rotating the carriage to loop cables prior to cutting or welding, or during actual work operations. We have also added a Lossy-Line Absorptive Filter RF Suppressor to provide increased protection of wiring and components connecting to the electrode. Our wire feeder exit trough is oxide coated to eliminate arcing and fusing. Its trough pivot device is altered to permit more flexibility and to provide a lock-in feature to center tracking. A similar horizontal travel locking device was added to the cutter head to prevent lateral carriage motion while cutting. Our cutter tool feed actuator includes ratchet depth set control.

### 5. MACHINING STUDIES

#### 5.1 General

Considerable time was spent to check and generally confirm Air Force machining data and to develop cutting and milling techniques for stainless steel and Inconel piping. We noted that cutting criteria applicable for 300 series stainless steel pipes do not apply for Inconel work. Available Inconel pipe was chosen to approach Hastelloy N material characteristics. We were able to prepare beveled pipe joints.

Cutter trials started in late February 1969. Major performance tests held during March and April included saw tracking studies and runout determinations and machining studies on (in order) 304 stainless steel, 347 stainless steel and Inconel piping. We tested 1/16 in. and 3/32 in. thick high speed steel and Circoloy alloy slitting saws and high speed steel single and double bevel cutters. We varied cutter speeds, cutter feeds, and carriage travel rates to determine programmed operating combinations for acceptable tool performance and pipe surface finish. Test efforts also served to evaluate our equipment, and to develop acceptable machining techniques for both slitting and beveling pipe to prepare desired pipe end configurations for welding. We noted particularly that pipe wall thickness variations, even within the allowed

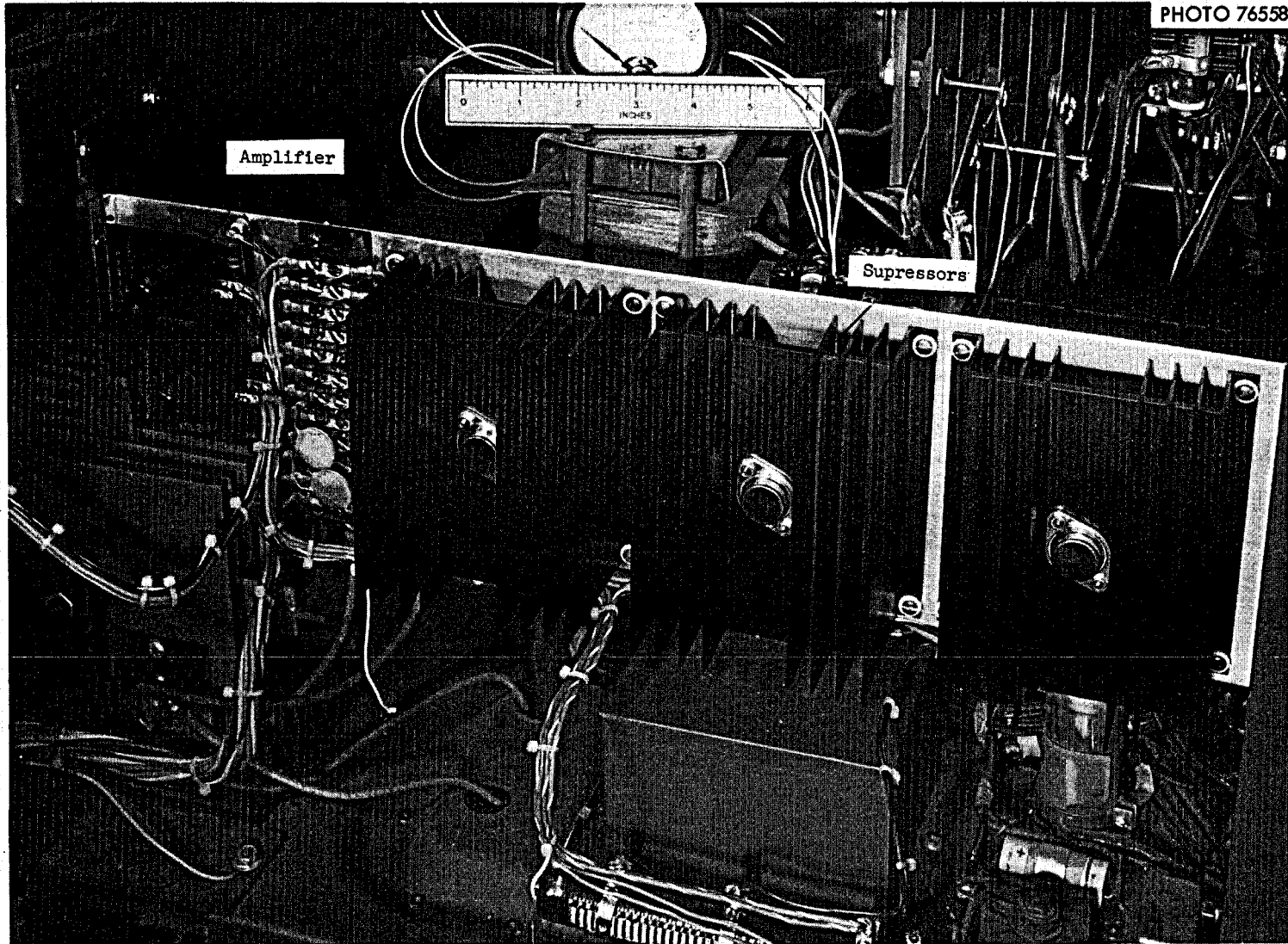

Fig. 9. Modifications to Welding Machine Circuits.

code limits for commercial piping, greatly complicate the joint machining requirements for dependable weld joint geometries.

## 5.2 Equipment Evaluation

The machining head appears to have capability to cut pipe, trim ends square, and to prepare end bevels. Little difficulty is encountered in machining stainless materials; problems, however, arise in cutting Inconel because of its work-hardening tendencies.

All ORNL machining tests were performed on horizontal piping. Slitting saws and double bevel cutters track true within approx. .003 in. Single bevel cutters tend to walk out of, and away from the cut, especially on the harder Inconel pipe. Cutter drive motor power and speed control capabilities appear adequate. The carriage and machining head will withstand loading and vibrations caused by the milling cutters with proper travel speed and tool feed selection. Improvements, however, are required to provide a stronger and more positive cutter depth control and to give more stable longitudinal adjustments. A ratchet-controlled worm gear depth control is contemplated for more precise feed capability. A locking clamp already installed to the longitudinal adjustment appears to adequately prevent axial cutter shifts.

The cutter drive motor and its speed reduction gear train work well. We have observed no signs of motor overheating during performance tests, even during severe milling operations. The 110 V ac motor is rated at about 5 amps; 2.5-amp readings were the highest noted in test operations. Motor speed control appears adequate, for speeds ranging from about 30 rpm to about 120 rpm. Observations to date indicate the carriage drive may be the limiting factor on cutting capability. We have observed roller slippage on the pipe, and at times have tripped the drive roller circuit breaker protection. Cutter feed and carriage speed adjustment changes, however, restored operations. During a recent maintenance period to revulcanize the roller viton friction surfaces we found a broken shear pin on one of the two carriage drivers. We do not know when this pin sheared, or for how long we may have operated with but a single carriage drive roller. (The other motor operated satisfactorily, but slipped within its concentric cannister housing. Available indicator signals registered proper dual motor operation but not the effect of the sheared pin.) Therefore, we are uncertain how much the cutting performance may be limited by the carriage drive system. However, we were able to make the machine work even with only one motor actually driving its roller.

## 5.3 Tooling

We have cut with high speed steel and Circoloy alloy slitting saws and milling cutters. The alloyed tool teeth appear to stay sharper longer, possibly by as much as a factor of one and a half. Early results from Inconel machining experimentation indicate that the cutting edges of all cutter teeth must be generously relieved to

provide ample clearance for chip fallout. Free falling chips minimize work hardening tendencies for Inconel pipe. It is also quite important that all teeth of a cutter engage the work during the cutting. Off the shelf commercial cutters used to date appear to cut with usually only about a fourth of their teeth. Improved cutting was noted when cutters were reground locally to precision specifications; almost seventy-five percent tooth engagement can be attained. We further noted the importance of tool travel and cutter speed adjustments for Inconel pipe work. Available machine shop machining data do not apply to the orbital cutting assembly because it does not have the driving power of shop machines. Also, dry machining is specified for nuclear system maintenance because coolants might contaminate the nuclear system. Therefore the tool travel, cutting speeds and tool feed rates must be much lower than usual shop practice.

The table on the following page shows the number of inches of cut a blade can be expected to make before it must be resharpened. The table also shows how deep the blade would cut in traveling the indicated number of inches around a 6-in.-diameter pipe, taking a 30-mil or a 12-mil cut, as indicated. The short cutter life experienced in test operations means that blades will have to be replaced frequently. We plan to test carbide cutter blades in hopes that they will last longer.

#### 5.4 Machining Feeds and Speeds

Efficient cutting requires the thickest possible chip per cutting tooth, but may have to be compromised somewhat to obtain reasonable cutter life and proper surface finish. This is particularly true in the case of high-nickel steels where the base material tends to work harden with the result that chip removal is inadequate or incomplete.

We selected Air Force recommended cutting speeds between 70 and 80 surface feet per minute for stainless steels and chose 50 feet per minute for Inconel in order to achieve reasonable cutter life. The cutting speeds correspond to approximately 100 and 62.5 revolutions per minute for our 3 inch diameter alloy steel slitting saws. Test verified feed per tooth selections compatible with tool strength and rigidity were .001 in. for stainless work, and about .0005 in. for Inconel. We chose respective travel speeds of 3 1/4 in./min. and 1 in./min. for the 32 tooth saws based on the formula

$$\text{FEED per TOOTH (mils)} = \frac{\text{TRAVERSING SPEED (in./min.)}}{\text{No. TEETH CUTTER} \times \text{SPEED (rpm)}}$$

Our feed per tooth rates are low when compared to rates in standard machine shop work, but are still creditable considering our small sized and low powered equipment. The depths of cut depend on available horsepower and cutter shapes, and on the sharpness of the cutters, as they in turn affect the power required at the cutter motor spindle. We repeatedly cut .030 in. deep into stainless, and .015 in. into Inconel. We anticipate deeper cutting capability with the "all carbide cutters" now on order.

Table 1. Expected Life of Cutter Blades

Description	Blade Lifetime			
	In Stainless Steel		In Inconel	
Saw Tooth Speed	70 to 80 ft/min		50 ft/min	
Carriage Speed	3 1/4 in./min		1 in./min	
Feed Per Tooth	.001 in.		.0005 in.	
	Inches of cut, average depth 30 mils. inches	Total Depth of cut, 6-inch pipe wall. inches	Inches of cut, average depth 12 mils. inches	Total Depth of cut, 6-inch pipe wall. inches.
1/16-in.-thick slitting saw, 3 in. dia., 32 teeth high speed steel	530	3/4		
1/16-in.-thick slitting saw, 3 in. dia., 32 teeth Circoloy alloy*	800	1 1/8	730	7/16
3/32-in.-thick slitting saw, 3 in. dia., 32 teeth high speed steel	430	5/8		
3/32-in.-thick slitting saw, 3 in. dia., 32 teeth Circoloy alloy*	650	7/8	600	11/32
70° included double angle mill 2 3/4 in. dia., 20 teeth, 1/2 in. wide high speed steel	470	11/16	420	1/4

\*Trade name for Circular Tool Company (Providence, R.I.) special high-speed steel alloyed blades of high carbon, medium chrome, high vanadium, high tungsten and medium cobalt composition.

### 5.5 Machining Techniques for Slitting and Beveling Pipes; Pipe End Preparation Requirements for Welding

An important feature desired for pipe weld joints is a perfect match for adjoining pipe ends. Pipe inside walls must align and must be concentric. Regardless of the geometry of a selected joint, whether it is V-bevel, J-bevel, or butt, precision fitup and mating geometrical concentricity will be required, along with square-cut ends and a uniform gap, or complete contact, of the joint ends.

ASME Materials Specifications, Section Two, Boiler Code for Piping permit various diametrical and wall thickness dimensional variations. Section SB 167 for Nickel-Chrome Alloy Pipe, as an example, permits an allowable eccentricity of pipe inside and outside diameter up to ten percent of the nominal wall thickness. Comparable SA 106 Steel Pipe Specs allow for 12 1/2 percent thickness variations below nominal pipe wall thickness. Diameters for large piping may vary as much as 1/8 in. All commercial pipe is governed by these specifications. Our experience indicates that piping dimensions vary at least as much as, or slightly more than the allowable tolerances.

Figure 10 illustrates problems encountered when we cut commercial piping for a J-bevel weld joint with our orbital equipment. The carriage rollers ride the pipe outside surface, which then becomes the reference surface for the cutter. For simplicity, Fig. 10 shows the end view eccentricity about only one centerline. In practice, one encounters eccentricities in several planes. The two elevations shown represent matched and mismatched joint alignment. Mismatching destroys mating inside diameter surface contact and prohibits proper root pass weld penetration. To achieve matched and aligned joint surfaces requires sensors and controls which will properly regulate the root pass weld variables (weld current, -speed, -wire feed, and -arc voltage) to adjust for variations of the joint. To date we have no sensing means which will automatically adjust the programmed weld variables for non-uniform geometries of the weld joint.

Figure 11 illustrates how a remedial cut can be taken to approach uniform wall thickness for pipe weld joints. This requires that the operator obtain accurate dimensional information from his initial slicing cut so that he can properly position and feed the cutter for subsequent machining. A wax impression of the pipe end contour could be used for remote work applications. If the pipe is contaminated and then contaminates the impression device, duplicate non-contaminated replicas can be made in hot cells or glove boxes via a recast plaster of paris process. This technique of remote replication has been used successfully in working with very highly radioactive materials.

Figure 12 shows one way of field matching a pipe end with a pipe stub previously welded onto a replacement component. For reactor maintenance, replacement items such as pumps, heat exchangers, etc., are all jig prefabricated. A blank end stub of slightly heavier schedule pipe, to gain a smaller inside diameter for subsequent fitup machining, could be field ground to an impression replica of the pipe end.

A machining technique has been developed for remotely preparing J-bevel pipe ends for welding. Figure 13 schematically represents an in-cell maintenance cutting procedure which tends to compensate for the variations in pipe wall thickness which, under the ASME Code, can be as much as 12 1/2%.

1. Step 1: Make a light cut around the pipe with a thick slitting saw and inspect for true tool tracking. Continue slitting to the predetermined depth which will leave a land surface for the root weld.
2. Step 2: On the cutter shaft, mount a hardened steel thrust washer and a single-angle milling cutter so that the washer will ride in the slit made by the saw and will guide the bevel cutter.
3. Step 3: After making the bevel cut, insert a thin slitting sawblade and cut through the wall.
4. Make a wax impression of the cut joint. Make a plaster of paris non-contaminated replica.
5. Machine to a constant land wall thickness at the joint by cutting metal from segments of the land surface where measurements of the replica indicate it is too thick.
6. Make a second replication of the joint for use in out-of-cell machining on the stub end of a replacement component to make it fit the pipe inside the cell.
7. Use information from the replica to set programmer weld current curves so that they will compensate for variations in the arc gap caused by out-of-roundness or by the machining to give constant land wall thickness.

All of our machining operations must be accomplished in the standard "milling up" mode of operation where the cutter tooth in contact with the pipe is moving in the same direction as the carriage. We lack rigidity for reverse, or "climb mill" cutting. Our torsion bar clamping action on the carriage roller does not give enough friction contact for climb cutting.

## 6. WELDING STUDIES

### 6.1 General

Orbital TIG welding operations on pipe require precise weld joint machining to obtain concentric pipe inside diameters and matched pipe wall thicknesses as well as near-perfect alignment of the respective two joint members. Failure to meet these requirements results in root welds that are undercut, lack full penetration, or that have too much penetration, resulting in excessive convexity. Fill-pass weld criteria



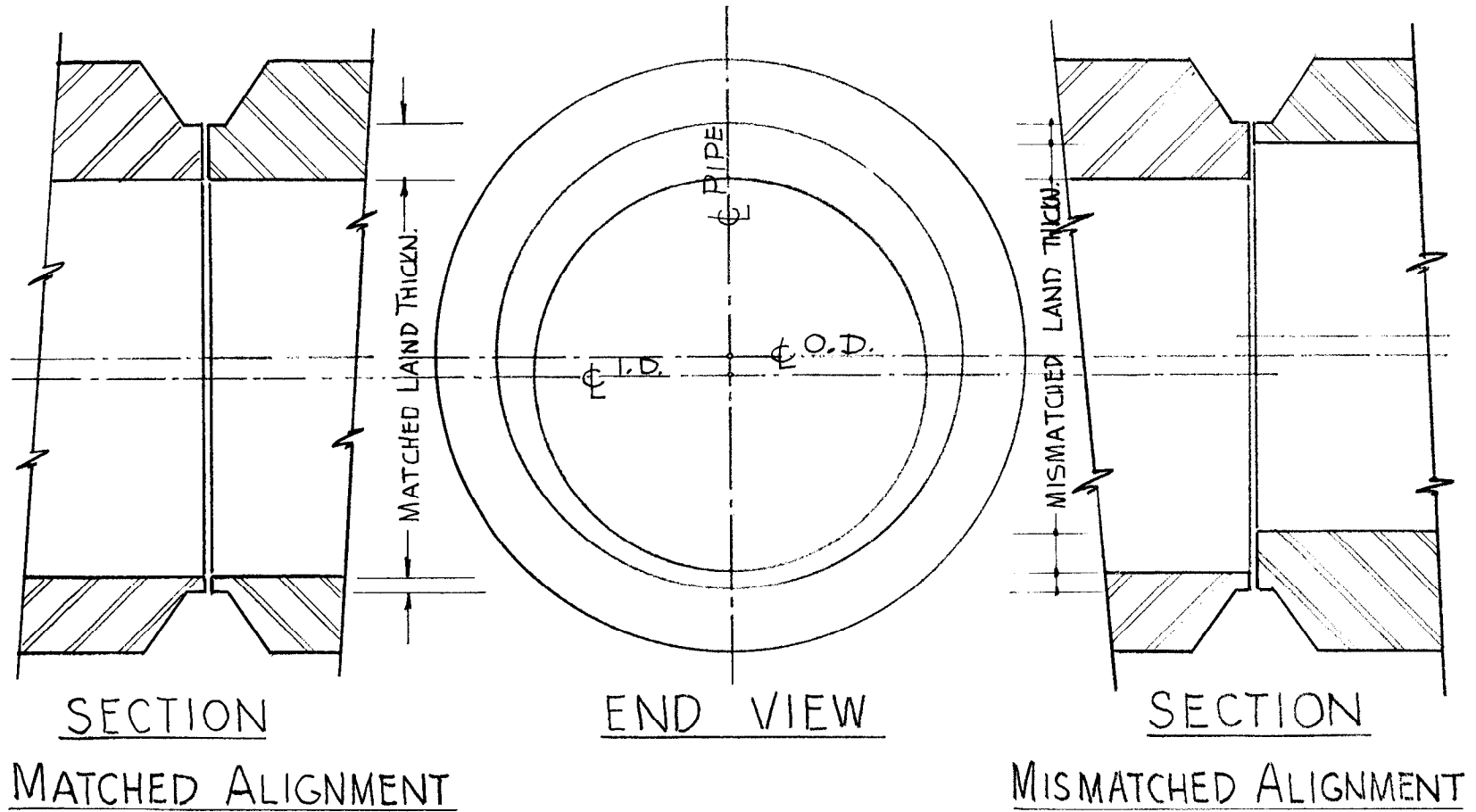

Fig. 10. Orbital Cutter (Riding Pipe O.D.). Typical "As Cut" Pipe Joints.

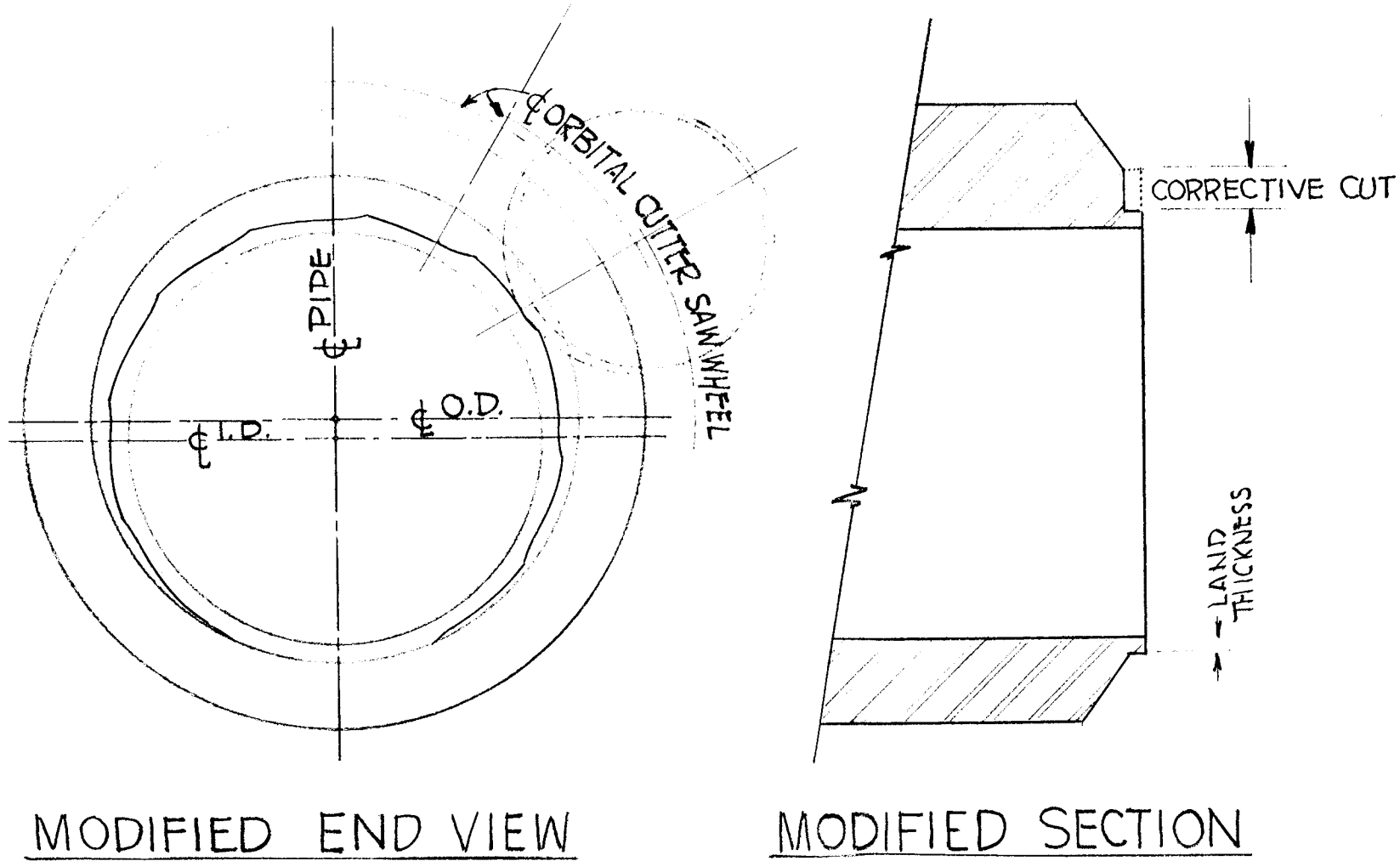

Fig. 11. Orbital Cutter (Tiding Pipe O.D.). Corrective Joint Cutting Plan.

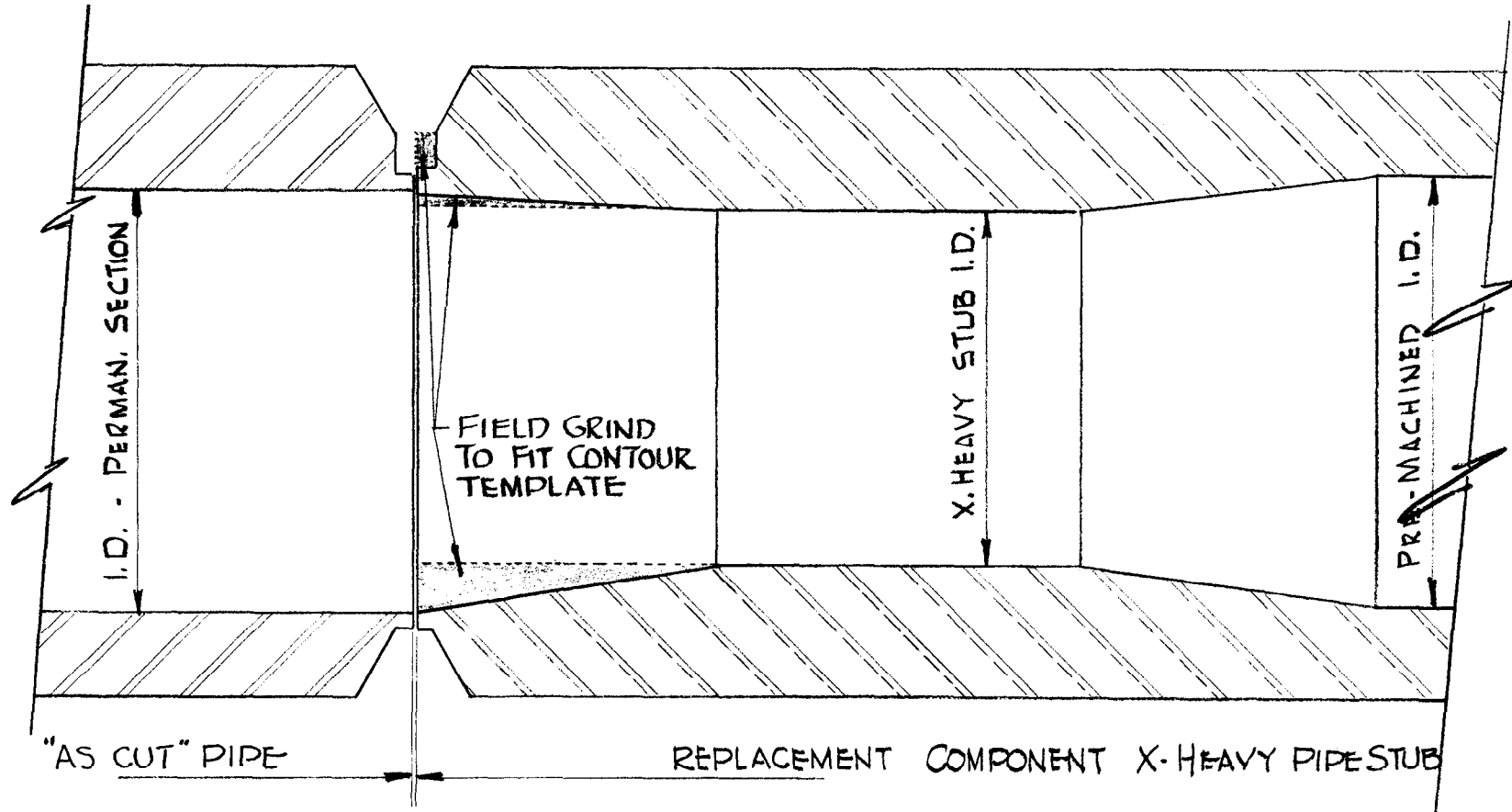

Fig. 12. Modified Final Joint Preparation.

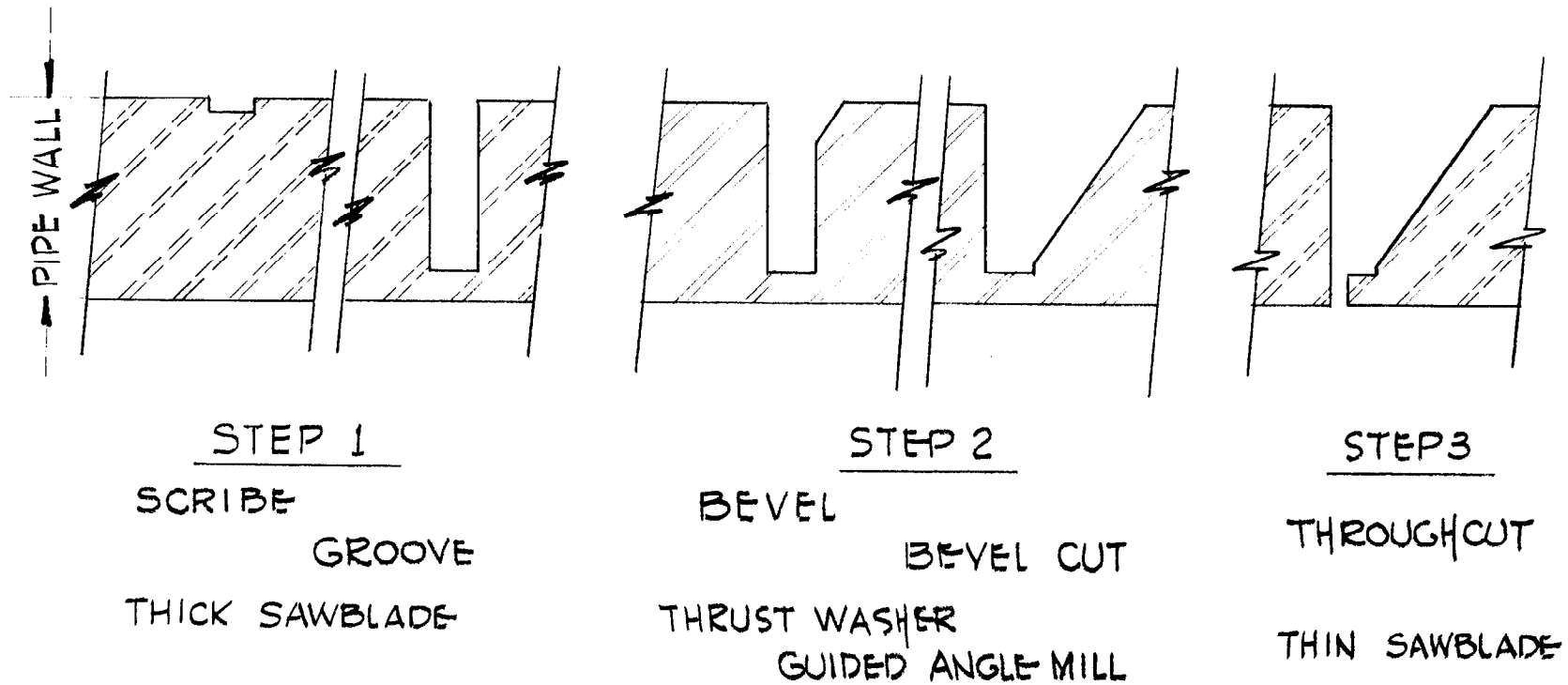

Fig. 13. Pipe Joint - Machining Sequence.

do not appear to be quite so critical, though we note a dependence of successive welds on prior weld passes. It is quite simple to lay good fillers over good root welds, or over good prior filler welds. It is difficult to perform remedial tasks over poor substrates. All these observations are based upon our recent work, which has generally involved extra-heavy 6-in.-diameter, 347 stainless steel pipe prepared with V- or J-bevel joints, and always fitted up without joint gap, and without weld inserts. Remote work on nuclear systems cannot use gap joints or the common weld insert rings.

Test operations with the orbital welding equipment were started during late February 1969. The first tests consisted of simply placing weld beads around the exterior surface of the pipe. Subsequently, V- and J-bevel pipe-joint root and filler pass weld tests were tried. We had hoped that acceptable root pass weldments could be obtained without having to do the precision machining that is required for close alignment and fitting of mating surfaces. However, the test welds showed that preparing the surfaces for precision matching and alignment is important in achieving quality welds.

Because it is time consuming and difficult to do precision machining by remote control, we plan to experiment with joints in which one preapplies weldwire filler metal to one of the two joint ends prior to placing the pipe inside the cell. This type of joint preparation permits plain fusion root pass welding, and requires no other filler wire additions. It should also greatly reduce the requirements for precision joint matching and alignment. Several highly successful root pass welds have just been performed by a similar method in which the pipe ends were machined to include an integral flat washer on one of the two mating J-joint sections. This washer permitted the root pass weld to be a single fusion weld which, in the tests exhibited excellent bead shape and full weld penetration.

At the moment we still lack essential information to suitably program the pipe root pass weld (with filler wire addition) for pipes in the horizontal plane. We have found no easy solution to the problem of sensing the weld puddle behavior as it relates to consistent full weld penetration. Such a sensing capability would permit automatic control and would make it possible to do remote welding with far less critical specifications for prior joint preparation. We have, however, recently coupled a Sanborn 150 Recorder to our weld programmer to study simultaneous data printouts of the inter-related weld functions (weld current, - travel speed, -wire feed rate, -arc voltage, and -arc voltage control). We have just begun to learn how to select and introduce proper weld programs for controlled high quality welding. There appears to be an excellent chance that we will soon be able to develop joint preparation, fitup, and weld criteria for consistent reactor quality welding.

We observed manual TIG welding operations in an attempt to study just how a welder actually manipulates his feed wire relative to his weld puddle. Slight pulsing of the wire advance motions were noted,

with speed adjustments to maintain the wire at the weld puddle's lower edge. For the present we lack built-in programmer wire feed pulse capability. We do, however, have the capability for weld current pulsing with up to 50 amperes peak to peak pulse amplitudes at either 40 or 60 pulses per minute. However, these pulses do not give the puddle stability observed in manual welding. An improvised method of wire feed pulsing was tested and appeared to give improved puddle stability, better arc tie-in to the joint walls, and uniform bead periphery. A Wavetek wave function generator provided 3 cycles per second pulsing with 50% on and off times. Additional trials will be scheduled with refined circuitry.

## 6.2 Preweld Joint Cleaning

Stored metals will form external oxide coatings. These oxides are refractory. Excess power (weld current) is required to obtain initial weld penetration when metal surfaces are oxide coated, and this often results in weld porosity due to hydration of the oxide. Once penetration has been achieved, new problems arise. One encounters difficulties with weld puddle control, especially in or near overhead weld positions. Weld deposits are uneven with balling tendencies and void inclusions.

Routine cleaning procedures of stainless steel wire brushing to cut oxide coatings and wiping with solvent to remove surface dirt and grease traces are necessary for all welds with the present orbital equipment. Additional draw filing, or grinding, may be required for filler passes to remove sharp notches or protrusions to obtain smooth, blended surfaces.

## 6.3 Joint Fitup Tolerance

Joint mismatch has already been listed as a cause for poor root pass welds in horizontal pipe lines. Mismatch is most critical in the overhead or 6 o'clock pipe position. Here a slight mismatch of adjacent inner diameter pipe joint lips, commonly referred to as mating land surfaces, causes the weld to pull out, or suck back metal due to gravity conditions. We concluded that it will be necessary to match pipe bottom quadrants most precisely for best weld results, since misfit conditions can be tolerated to a greater degree in the top quadrant surfaces. Pipe joint mating surfaces should preferably make physical contact on fitup for radioactive system remote maintenance welding. Purge gas losses are minimized with contacting surfaces, and filler metal additions are reduced, also.

## 6.4 Inert Shield Gas

There is a difference in ionization potential of inert gases which affect the heat input to the weld zone. Helium requires only about 60% of the welding current required for an equivalent weld with argon shield gas. Different arc plasma shapes result. Argon spreads the welding heat; helium concentrates heat. Air Force experimentation indicated

that wide argon plasmas give best results for work with stainless welding. All ORNL work has been done with argon shielding gas. We have also used argon gas to purge pipe interiors, usually with a 20 cfh gas purge flow.

### 6.5 Electrode Configuration

Air Force experimentation indicated that better welds can be obtained by tapering the torch electrode tungsten to a  $60^\circ$  included angle. Electrode configuration influences the arc spread pattern. The tendency of an arc to spread to an adjacent area causes the weld nugget to fuse only intermittently to the joint sidewalls, resulting in lack of fusion and an uneven, knotty-rope appearing surface on the weld bead. It is practically impossible to lay subsequent acceptable fill passes over such defective surfaces; one must resort to corrective interpass machining and blending prior to proceeding with further welding. We tentatively standardized on a  $60^\circ$  included electrode angle for our stainless welding work.

### 6.6 Automatic Arc Voltage Control

It is necessary to control both the torch-to-pipe distance and the torch electrode-to-weld puddle distance to maintain a constant arc length and a constant arc voltage with a selected inert welding gas. The orbital system weld head is spring loaded within the carriage. A cam follower rides the pipe's perimeter and actuates a spring to perpendicularly vary the weld head to work-piece spacing and continuously compensate for ovality or local flat spots in the piping. North American Rockwell also devised an electronic arc voltage control (AVC) system to maintain constant electrode-to-weld puddle spacing. The Air Force programmer built by Rockwell includes a feedback system which monitors the arc voltage, compares it to a predetermined value, and, as required, generates a correction signal to adjust the wire feed rate. The AVC system thus actually senses or observes changes in the arc gap as changes in arc voltage to increase or decrease the filler wire speed to deposit larger or smaller weld puddles to maintain preset gap.

The angle of the tip of the electrode determines where the arc will initiate. Arc emission can occur from any spot of the heated electrode's tapered emitting surface. Weld bead shape can be somewhat varied by changing electrode tip angles. Precision, caution and care are required even with AVC regulation to confine the arc emission direction to keep from bumping into pipe joint sidewalls or weld puddles. Additional precautions are necessary to prevent contacting the electrode with the filler wire during the overlap portion of the weld. The wire feed motor cutoff point must be programmed to stop in the initial downslope portion of the weld current.

## 6.7 Pre-Weld Positioning

Pipe ends to be joined by welding must be rigidly held in position during welding to prevent weld heat-induced pipe movement at the joint due to expansion and contraction forces. Pipes may be clamped or fusion tack welded prior to the root pass.

We plan to use mechanical clamps for remote maintenance welding, as machine tack welding presents additional problems: after tacking, pipe joint groove surfaces of the tack must be machined to a thin, blended buildup; surfaces must then be wire brushed and solvent cleaned; machine tack welding must also be confined to the upper half of the pipe to prevent undercutting at the end of the tackweld.

## 6.8 Root Pass

The ideal root-weld pass requires the shortest possible arc length without "sticking" and with additions of as much filler wire as possible for crack sensitive metals. For pipe in horizontal runs weld passes should start in the overhead portion of a joint to take utmost advantage of the chilling effects of cold pipes. Pipe joint lands should ideally be uniform in thickness and in width. The angle for wire entry and the exit location of the wire feeder guide tube relative to the weld puddle are critical. Experimentation to date has followed the listed Air Force recommended settings:

For stainless steel welding: Root Pass Arc Length =  $1/16$  in.

Filler Wire Rate, approx. 10 in./min.  
with .045-in. wire

Tool Drive (carriage) Travel Speed, approx.  
4 in./min.

Pipe Joint Lands, approx.  $1/16$  in. wide x  
 $1/16$  in. high

Wire Feeder Entry Angle 25 to 30° above  
the tangent point with pipe surface,  
 $1/4$  in. away from the electrode, with  
the wire dragging the groove directly  
below the electrode.

AVC set at 8  $1/2$  to 9 volts with argon  
purge gas

Start Position approx. 9 o'clock

Some indications of root pass weld quality can be observed from programmer voltmeter and wire feed rate meter readings. Both meters indicate any variations in arc length. The weld bead is not penetrating the pipe joint if voltage readings hold steady but wire feed



rates register only below selected rates. Usually a small increase in welding current will remedy this situation. If, however, the wire feeder motor builds up to the set rate, and voltage continues to climb, poor welding also results, and the cycle should be stopped at once. The problem will usually be an excessive joint gap formation with too much pushthrough in the upper quadrants of the pipe, filler wire bound up within the wire feeder drive and not feeding into the weld, or excessive puddle fluidity in pipe vertical positions causing puddle flow away from the electrode tip.

### 6.9 Fill Passes

Satisfactory weld fill passes do not appear to present great problems. The second weld pass, or first fill pass, requires some special care to properly add filler wire and obtain weld buildup without affecting the root pass drop-through. Heat input selections for this and subsequent passes require only fusion to the previous pass and to the joint sidewalls. Oscillation of the weld torch assists to assure fusion into the sidewall. Current pulsing tends to maintain a stable weld puddle.

Few programmer input changes are required for initial fill passes, except to add torch oscillation and to halve the wire feeder exit to pipe surface entry angle. Final fill passes can be made with increased weld power, wider oscillation, and faster wire feeds. An 11 o'clock first filler pass start position generally helps to balance partial distortion of the pipe created by the root pass.

### 6.10 Repair Welding

The orbital welding system can also be employed to repair some weld defects. Two common defects are intermittent lack of fusion along the sidewalls of a joint, and cold, balled, ropey-like deposits along a weld joint sidewall. Resultant defective surfaces then prevent subsequent weld pass puddles from wetting and flowing smoothly. Weld beads exhibit areas of lack of fusion and void inclusions.

Placing the electrode just ahead of the poorly fused area and manually starting a new weld pass without filler wire additions or oscillation will generally remelt and fuse the weld. Pinholes can also be repaired in a similar manner with the torch located directly over the pinhole prior to a delayed electrode "start-fire."

A procedure to fill local weld areas which have been purposely ground out to remove weld defects is to place the carriage about 1/2 in. in front of the area to be filled, set a short arc gap of 1/32 in., and initiate a weld cycle. The AVC wire feed control will start to add wire as soon as the arc gap increases once the carriage traverses the recessed area. The wire feeder motor will again shut off on the far side of the depressed area to permit manual weld downsloping.

## 7. SPECIAL ORBITAL EQUIPMENT MAINTENANCE REQUIREMENTS

Orbital equipment used for maintenance of reactor systems may become contaminated. In such cases, repairs to the orbital equipment, or component replacement operations may have to be performed in shielded hot cells. Viton-rubber-coated roller surfaces may require periodic interchange; motors, cutters, torches, etc., may have to be replaced. Equipment maintenance procedures are listed for major equipment in-cell components which might be subjected to contamination. Work experience to date suggests a number of modifications which could be made to the orbital equipment to provide better access for repairs to be performed by remote control inside a hot cell and to reduce the time required for maintenance of the orbital equipment. The changes indicated on the basis of experience to date are described in the following paragraphs.

### 7.1 Carriage

7.1.1 Drive Rollers - Minor changes to the wire trough of each carriage arm and provisions for an externally accessible, flat, Winchester type connector in respective motor circuits would permit faster interchange for spare roller assemblies. The removal of two roller end plugs and two roller end cap screws and opening the electrical connector frees the drivers.

7.1.2 Idlers - Idler replacement presently requires the somewhat tedious disassembly of electrical connectors, the carriage rear frame and side walls, and the link pins. For maintenance to be performed inside a hot cell some simplifications are possible, especially with use of modified right angle electrical connector replacements. We recommend jugged holddown devices for all hot cell idler interchange operations to maintain the highly critical centerline alignment of the jackscrews with the torsion bar gear and the torque arm gear.

### 7.2 Electrical Items

Access is available for all component electrical wiring and accessory items by simply removing cover plates. More extensive use of miniature connectors might be desirable for electrical system parts which might require maintenance during developmental test periods.

### 7.3 Milling Head

Hot cell jigs will be required to support the milling head for cutter replacement. The cutter is replaced by removing the bolt holding it to the output shaft. Washers are employed to hold the cutter tightly.

Improvements are necessary for more precise depth of cut adjustments and for the horizontal cutter placement adjustment. Precision worm gear replacements are contemplated for existing miter gears. We also plan to add an airline connection through the rear carriage panel to modify cutter motor forced cooling and to keep chips generated during cutting from entering gear drives, the motor, and the positioning adjustments.

No problems are expected for routine cutter motor servicing involving backplate, control panel and cutter removal. Motor brushes can be replaced by simply moving the motor partially out of the housing. The gear train connecting the motor to the output shaft is servicable by disassembling the motor canister.

For our next model, cutter motor speed control circuitry will be eliminated from the head and transferred to the programmer.

#### 7.4 Welding Head

Periodic cleaning of the weld head is important to prevent high-frequency arcing. The weld head is disassembled by first removing the wire feed spool. The torch, oscillator, and wire feed mechanism slide off the vertical guide as a unit after the removal of the vertical adjustment knob. The common mounting block is removed by unscrewing the horizontal guide pins and the setscrew on the horizontal adjustment shaft. The wire feed is disconnected from the torch and oscillator by removing two screws. The feed pressure-adjusting screw should be removed to inspect bearing races between rotating disks.

Special, simple remote tooling will be required to replace threaded torch assemblies, or to interchange electrodes.

Jigs are recommended to support the weld head for hot cell maintenance work. We plan weld head design change improvements for our next model's oscillator adjustment cam to the lid latch device, and to the horizontal and vertical torch movement gear trains. Present items do not work well with remote tooling. We also plan to transfer the present "touchdown" light, which indicates electrode contact with the work on setup, from the welding head to the programmer.

#### 7.5 General

In the future we also hope to incorporate brighter directional lighting for both the milling and weld heads, to possibly enlarge the viewport openings, and to alter the front panel of the carriage to permit improved viewing for hot cell and operational setups and possibly for monitoring use in actual reactor repair use.

We are also investigating fluidic sensing and control devices for remotely setting and controlling oscillator operation. This would reduce costs, gain reliability, improve weld head rigidity and compactness and eliminate maintenance time requirements to place long handled tools into the cell to alter the present electro-mechanical oscillator's amplitude settings required for successive fill passes.

## SECTION C

## 8. PROGRAM PROPOSAL: DEVELOPMENT OF REMOTE CUTTING, WELDING AND INSPECTION EQUIPMENT FOR REACTOR SYSTEM MAINTENANCE

## 8.1 Overall Requirements for Remote Cut/Weld Maintenance

The question of how maintenance will be accomplished is one which must be answered at the time a reactor system is being designed in order that appropriate provisions for maintenance will be included in the design. In considering the design of a Molten Salt Breeder Reactor, ORNL has explored the reported experience in the whole field of reactor maintenance problems and methods of making repairs. The advantages of welded joints in nuclear systems are generally recognized, but there is no suitable equipment for performing remote cutting and welding operations in the ways reactor system maintenance would require. However, there are some new types of equipment which show promise for radioactive system applications after further development of remote controls and other special features for work in high radiation areas.

The orbital cutting and welding equipment developed for the Air Force and adapted for remote handling and operation by ORNL demonstrated good performance in tests of a prototype unit, and thus gave support to the formation of a new philosophy for maintaining piping systems and vessel closures in radioactive systems. The new maintenance philosophy is to rely on the use of remote cutting and welding equipment to remove from the nuclear system any component which fails and to install a replacement. This provides a great deal more flexibility and reliability than a piping system in which flanged joints must be opened and resealed by remote control. Remote cutting and welding would provide for all maintenance on the piping system and on seal welding the flanged openings in vessels. For maintenance of the electrical, instrumentation and other systems, long-handled tools or special remote control devices would be used in the manner already demonstrated in the MSRE and other reactors.

The orbital equipment will require further modifications and additions to meet the special needs of remote maintenance operations on pipes and vessels, so that, for example, the equipment can be positioned at the work site by remote control, without being able to see directly what is being done. The Air Force cutting and welding equipment has semi-remote controls for the cutting and welding operations and these will require additional special features for fully remote control.

Work on radioactive systems not only requires remote controls for all operations, but also requires that the maintenance equipment be fabricated of materials that resist the damaging effects of radiation and withstand high temperatures and the corrosive action of decontamination chemicals. The performance of remote maintenance

operations will require special attachments for viewing, measuring, and sensing from a shielded work area and for performing inspection operations by remote control. This will necessitate the development of highly specialized apparatus plus new techniques and procedures for examination, measurement and inspection. Remotely controlled methods for accurately positioning and aligning large pipes must be developed in order to be able to do high quality welding on pipe joints. There are many interrelated and difficult problems for which solutions are not now available. The development programs described below are proposed to provide the needed equipment and techniques for remotely controlled, automated cutting and welding on highly radioactive piping and components of nuclear systems.

The remote maintenance equipment development program will first be concerned with completion of the testing and evaluation of the Air Force orbital equipment with special emphasis on improved cutting capability for extra hard materials such as alloys with high nickel content, and the development of proper techniques for acceptable root pass welding. Successful completion of the testing and evaluation program should give assurance that the broader, long range development program can produce a fully automated and remotely controlled system which will meet the rigid quality requirements for maintenance on nuclear systems.

## 8.2 A Long-Range, Three-Phase Development Program for Pipe and Vessel Maintenance

The long range program encompasses three phases: general investigations of welding requirements and remotely controlled equipment for welding, an extended pipe-joint program, and a vessel closure program. It is proposed that the study of general remote welding problems and the development of equipment to handle the specific problems of reactor pipe joints and vessel closures should be pursued concurrently. Remote welding equipment modifications can be developed, studied, and tested at the same time general studies are in progress, with refinements from the general studies being added as they become available.

### 8.2.1 Phase I, The General Program

Major investigations under the general program are the basic studies of factors that determine the quality of welded joints in various metals, the studies of different welding techniques and controls needed to assure that weld quality criteria are met, the determination of materials and components that will withstand the effects of radiation, temperature, and of chemical decontamination treatments, the improvement of welding controls and programming apparatus, the development of equipment and techniques for remote-control alignment of components, and the determination of environmental and cleanliness criteria. For the applied phase of the general program, mockup work is planned to evaluate various new or modified types of equipment and remote controls, especially the pipe positioning and movement schemes designed to achieve acceptable pipe joint alignment prior to welding.

It is also recommended that the welding metallurgy of irradiated materials be investigated. It is important to know whether neutron irradiated pipe metal shows radiation effects which will affect welding and whether minute cracking will occur in heat-affected weld zones. At present, only limited data are available from tests conducted at ORNL.<sup>20</sup> Attempts to weld small corrosion samples removed from the MSRE gave effective welds in only 70% of the cases;<sup>21</sup> however, further testing indicated that better cleaning of the metal surfaces to remove salt residues prior to welding would solve the problem. Test specimens should be obtained from actual irradiated sections of reactor pipe in which the combined effects of neutron irradiation and thermal cycling are present. The Navy, has informally expressed interest in studying the welds in highly irradiated sections of nuclear submarine pipe systems. Valuable data and maintenance experience might be obtained, in cooperation with the Navy, by using the remotely controlled cutting and welding equipment to cut out and replace test sections of the ship-board nuclear system piping so that the removed sections could be subjected to detailed study of the old welds and of new welds made on the irradiated metal.

#### 8.2.2 Phase II, The Pipe Joint Program

The continuation of the pipe joint program will require development, and testing of prototype carriages for the larger pipe sizes, design, development, and testing of second generation cutting and welding heads, and the establishment of specific techniques, methods and equipment for cutting and welding various metals. It is also planned to use the findings of the environmental study and the materials and components study, carried out under the general program to upgrade the materials and components of the pipe joint maintenance machinery to withstand the effects of radiation, temperature, and of decontamination treatments in actual nuclear applications.

#### 8.2.3 Phase III, The Vessel Closure Program

A dual approach is suggested for the development of equipment for cutting and welding of seals on the manhole-type openings in large vessels in reactor systems. The initial cutting, beveling and welding work will be performed using various commercially available components adapted for remote control. Performance appraisals from these tests will permit the development of modifications to overcome the problems that are encountered and after further tests, the final component specifications will be established for industry to supply complete equipment systems for further testing on vessel closure maintenance. Another part of the program will be concerned with application of orbital vehicle machinery to the special problem of seal welding on lips installed around manhole covers. The pipe welding development program will determine the applicability of the modular insert carriage scheme for remote maintenance work. After obtaining satisfactory performance on pipe welds, the welding equipment could be mounted on special carriages designed to suit the manhole cover geometries. These carriages should utilize the same cut, bevel, weld and inspection

inserts and operate from the same programmer as the pipe welder. Great time savings and sizeable dollar savings can result from applying such a system directly to seal welding. Spare part problems and inventories are also minimized. The final procurement of the components selected to suit the needs of a nuclear environment will incorporate the most promising apparatus, materials and components indicated by the development and testing activities.

#### REFERENCES

20. Molten Salt Program Semiannual Report for the Period ending February 28, 1966, ORNL Report No. ORNL-3936, p. 117, 1966.
21. Molten Salt Reactor Experiment Monthly Report for August 1968, ORNL Report No. MSR-68-123, p. 19, 1968.





Internal Distribution

- |                             |                                 |
|-----------------------------|---------------------------------|
| 1-3. MSRP Director's Office | 52. W. B. Cottrell              |
| 4. R. K. Adams              | 53. B. Cox                      |
| 5. G. M. Adamson            | 54. J. L. Crowley               |
| 6. J. L. Anderson           | 55. F. L. Culler                |
| 7. R. F. Apple              | 56. D. R. Cuneo                 |
| 8. E. L. Armstrong, Y-12    | 57. J. E. Cunningham            |
| 9. D. L. Aubuchon           | 58. J. M. Dale                  |
| 10. C. F. Baes              | 59. D. G. Davis                 |
| 11. J. M. Baker             | 60. R. J. DeBakker              |
| 12. P. S. Baker             | 61. C. B. Deering, AEC-OSR      |
| 13. S. J. Ball              | 62. J. H. DeVan                 |
| 14. C. E. Bamberger         | 63. S. J. Ditto                 |
| 15. C. J. Barton            | 64. H. G. Duggan                |
| 16. H. F. Bauman            | 65. A. S. Dworkin               |
| 17. S. E. Beall             | 66. I. T. Dudley                |
| 18. R. L. Beatty            | 67. W. P. Eatherly              |
| 19. M. J. Bell              | 68. D. Elias, AEC-Washington    |
| 20. M. Bender               | 69. R. J. Emmert                |
| 21. C. E. Bettis            | 70. J. R. Engel                 |
| 22. E. S. Bettis            | 71. E. P. Epler                 |
| 23. D. S. Billington        | 72. W. K. Ergen                 |
| 24. W. A. Bird              | 73. R. M. Farnham               |
| 25. R. E. Blanco            | 74. J. C. Feeman, Y-12          |
| 26. F. F. Blankenship       | 75. D. E. Ferguson              |
| 27. R. Blumberg             | 76. L. M. Ferris                |
| 28. A. L. Boch              | 77. B. Fleischer                |
| 29. E. G. Bohlmann          | 78. M. H. Fontana               |
| 30. C. J. Borkowski         | 79. A. P. Fraas                 |
| 31. G. E. Boyd              | 80. E. A. Franco-Ferreira, Y-12 |
| 32. J. Braunstein           | 81. J. K. Franzreb              |
| 33. M. A. Bredig            | 82. H. A. Friedman              |
| 34. E. J. Breeding          | 83. D. N. Fry                   |
| 35. R. B. Briggs            | 84. J. H. Frye                  |
| 36. H. R. Bronstein         | 85. R. M. Fuller                |
| 37. J. R. Buchanan          | 86. W. K. Furlong               |
| 38. C. A. Burchsted         | 87. C. H. Gabbard               |
| 39. D. A. Canonico          | 88. W. R. Gall                  |
| 40. W. F. Cartwright, Y-12  | 89. R. B. Gallaher              |
| 41. J. M. Chandler          | 90. J. H. Gibbons               |
| 42. C. J. Claffey           | 91. J. M. Googin, Y-12          |
| 43. F. H. Clark             | 92. W. R. Grimes                |
| 44. W. R. Cobb              | 93. A. G. Grindell              |
| 45. H. E. Cochran           | 94. R. W. Gunkel                |
| 46. C. W. Collins           | 95. R. H. Guymon                |
| 47. E. L. Compere           | 96. J. P. Hammond               |
| 48. K. V. Cook              | 97. B. A. Hannaford             |
| 49. W. H. Cook              | 98. P. H. Harley                |
| 50. J. W. Cooke             | 99. W. O. Harms                 |
| 51. L. T. Corbin            | 100. C. S. Harrill              |

101. P. N. Haubenreich  
 102. T. E. Haynes  
 103. R. E. Helms  
 104. P. G. Herndon  
 105. D. N. Hess  
 106. J. R. Hightower  
 107. J. W. Hill  
 108. M. R. Hill  
 109. E. C. Hise  
 110. H. W. Hoffman  
 111. D. K. Holmes  
 112-131. P. P. Holz  
 132. R. W. Horton  
 133-134. T. R. Housley  
 135. T. L. Hudson  
 136. W. R. Huntley  
 137. H. Inouye  
 138. H. F. Jackson  
 139. G. R. Jasney, Y-12  
 140. W. H. Jordan  
 141. S. I. Kaplan  
 142. P. R. Kasten  
 143. R. J. Kedl  
 144. M. T. Kelley  
 145. M. J. Kelly  
 146. O. A. Kelly  
 147. C. R. Kennedy  
 148. T. W. Kerlin  
 149. H. T. Kerr  
 150. F. Kertesz  
 151. J. J. Keyes  
 152. S. S. Kirslis  
 153. O. H. Klepper  
 154. R. B. Korsmeyer  
 155. T. S. Kress  
 156. J. W. Krewson  
 157. C. E. Lamb  
 158. J. A. Lane  
 159. C. G. Lawson  
 160. W. J. Leonard  
 161. P. S. Lee  
 162. R. B. Lindauer  
 163. A. P. Litman  
 164. E. L. Long  
 165. A. L. Lotts  
 166. M. I. Lundin  
 167. R. N. Lyon  
 168. R. L. Macklin  
 169. H. G. MacPherson  
 170. R. E. MacPherson  
 171. T. H. Mauney  
 172. R. W. McClung  
 173. H. E. McCoy  
 174. H. C. McCurdy  
 175. D. L. McElroy  
 176. C. K. McGlothlan  
 177. J. R. McGuffey  
 178. H. A. McLain  
 179. L. E. McNeese  
 180. J. R. McWherter  
 181. H. J. Metz  
 182. A. S. Meyer  
 183. E. C. Miller  
 184. R. L. Moore  
 185. G. Morris  
 186. D. C. Morrison  
 187. J. C. Moyers  
 188. H. A. Nelms  
 189. E. L. Nicholson  
 190. L. C. Oakes  
 191. W. R. Osborn  
 192. L. F. Parsly  
 193. P. Patriarca  
 194. A. M. Perry  
 195. T. W. Pickel  
 196. H. B. Piper  
 197. J. L. Redford  
 198. M. Richardson  
 199. R. C. Robertson  
 200. J. N. Robinson  
 201. W. C. Robinson  
 202. R. G. Ross  
 203. J. Roth  
 204. T. H. Row  
 205. H. C. Savage  
 206. W. F. Schaffer  
 207-216. Dunlap Scott  
 217. J. L. Scott  
 218. H. E. Seagren  
 219. J. H. Shaffer  
 220. L. J. Shersky  
 221. M. D. Silverman  
 222. M. J. Skinner  
 223-227. G. M. Slaughter  
 228. A. N. Smith  
 229. C. M. Smith, Jr.  
 230. F. J. Smith  
 231. G. P. Smith  
 232. O. L. Smith  
 233. P. G. Smith  
 234. I. Spiewak  
 235. R. C. Steffy

- |      |                    |          |                                      |
|------|--------------------|----------|--------------------------------------|
| 236. | H. H. Stoner, Y-12 | 255.     | J. C. White                          |
| 237. | R. A. Strehlow     | 256.     | G. D. Whitman                        |
| 238. | J. R. Tallackson   | 257.     | R. P. Wichner                        |
| 239. | E. H. Taylor       | 258.     | L. C. Williams                       |
| 240. | W. Terry           | 259.     | C. H. Wodtke                         |
| 241. | R. E. Thoma        | 260.     | L. V. Wilson                         |
| 242. | W. E. Thompson     | 261.     | M. M. Yarosh                         |
| 243. | D. B. Trauger      | 262.     | W. J. Yaggi, Y-12                    |
| 244. | W. E. Unger        | 263.     | Gale Young                           |
| 245. | T. K. Walters      | 264.     | H. C. Young                          |
| 246. | G. M. Watson       | 265.     | J. P. Young                          |
| 247. | J. S. Watson       | 266.     | E. L. Youngblood                     |
| 248. | H. L. Watts        | 267.     | F. C. Zapp                           |
| 249. | C. F. Weaver       | 268-269. | Central Research Library             |
| 250. | B. H. Webster      | 270-271. | Document Reference Section           |
| 251. | A. M. Weinberg     | 272-274. | Laboratory Records                   |
| 252. | J. R. Weir         | 275.     | Laboratory Records (LRD-RC)          |
| 253. | K. W. West         | 276-277. | Nuclear Safety Information<br>Center |
| 254. | M. E. Whatley      |          |                                      |

External Distribution

278. D. F. Cope, AEC-OSR  
 279. A. Giambusso, AEC-Washington  
 280-281. K. O. Laughon, AEC-OSR  
 282. C. L. Matthews, AEC-OSR  
 283-284. T. W. McIntosh, AEC-Washington  
 285. H. M. Roth, AEC-ORO  
 286. M. Shaw, AEC-DRDT  
 287. W. L. Smalley, AEC-ORO  
 288. D. S. Zachry, Jr., AEC-ORO  
 289-298. AFRPL (RPRPD/Capt. F. M. Cassidy)  
 299-300. Capt. F. M. Cassidy, USAF, AFRPL, Edwards AFB  
 301-302. E. E. Stein, AFRPL, Edwards AFB  
 303-304. Capt. J. L. Feldman, ASD, ASNJD-10, Wright Patterson AFB  
 305-306. Lt. A. B. Spencer, ASD, ASNJD-20, Wright Patterson AFB  
 307-321. Division of Technical Information Extension (DTIE)