

MASTER

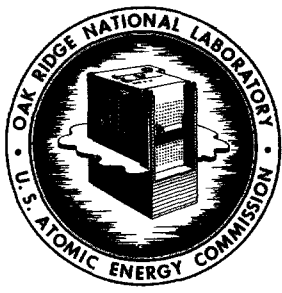

OAK RIDGE NATIONAL LABORATORY
operated by
UNION CARBIDE CORPORATION
NUCLEAR DIVISION
for the
U.S. ATOMIC ENERGY COMMISSION



ORNL - TM - 3767

DATE - May 5, 1972

HYBRID COMPUTER SIMULATION OF THE MSBR

O. W. Burke

ABSTRACT

A hybrid computer simulation model of the reference 1000 MW(e) MSBR was developed. The model simulates the plant from the nuclear reactor through the steam throttle at the turbine. The simulation model is being used to determine the dynamic characteristics of the plant as well as to discover the problems associated with the control of the plant.

NOTICE This document contains information of a preliminary nature and was prepared primarily for internal use at the Oak Ridge National Laboratory. It is subject to revision or correction and therefore does not represent a final report.

DISTRIBUTION OF THIS DOCUMENT IS UNLIMITED

This report was prepared as an account of work sponsored by the United States Government. Neither the United States nor the United States Atomic Energy Commission, nor any of their employees, nor any of their contractors, subcontractors, or their employees, makes any warranty, express or implied, or assumes any legal liability or responsibility for the accuracy, completeness or usefulness of any information, apparatus, product or process disclosed, or represents that its use would not infringe privately owned rights.

CONTENTS

	<u>Page</u>
1. Introduction	4
2. Description of Computer	4
3. Description of MSBR System	5
4. Development of the Computer Model of the Plant	6
4.1 Steam Generator Model	6
4.2 The Analog Computer Model of the System Exclusive of the Steam Generator	16
5. Results of Simulation Exercises	33
6. References	43
7. Appendix	44
7.1 A: Development of Computer Model	44
7.2 B: Steam Generator Equation Variables	66

NOTICE

This report was prepared as an account of work sponsored by the United States Government. Neither the United States nor the United States Atomic Energy Commission, nor any of their employees, nor any of their contractors, subcontractors, or their employees, makes any warranty, express or implied, or assumes any legal liability or responsibility for the accuracy, completeness or usefulness of any information, apparatus, product or process disclosed, or represents that its use would not infringe privately owned rights.

1. INTRODUCTION

In order to get a "feel" for the dynamic behavior of the MSBR plant as well as to discover the plant control problems and their solutions, it was imperative that a simulation model of the plant be developed.

Due to the highly nonlinear nature of the once-through steam generator, it was deemed necessary to have a highly detailed model of this part of the system. Consequently, the model of the steam generator was implemented on the hybrid computer. The reactor kinetics, core heat generation and heat transfer, primary heat exchanger heat transfer, piping lags, system controllers, etc., were simulated on the analog computer. The two computers were interfaced to form a unified simulation model of the system.

2. DESCRIPTION OF COMPUTER*

The ORNL analog-hybrid computer was used in the simulation. It consists of the new hybrid computer and the older analog computer. The hybrid computer consists of a PDP-10 digital computer and an AD-4 analog computer. The PDP-10 was manufactured by the Digital Equipment Corporation, Maynard, Mass., and the AD-4 was manufactured by Applied Dynamics, Inc., Ann Arbor, Mich. Essentially all of the older analog computer equipment was manufactured by Electronic Associates, Inc., Long Branch, N. J.

The PDP-10 digital computer is a 36-bit word machine with a fast memory storage capacity of 32K words.

The AD-4 analog computer is a solid state, ± 100 V reference machine. The mode switching is accomplished in 1 microsec. It contains patchable logic components

*Mention of manufacturers, products, brand names, etc., is for information purposes only and in no way implies an endorsement by ORNL or the U. S. AEC.

and the interface for communicating with the PDP-10 digital machine. The interface contains an analog to digital converter (ADC) with a 32-channel multiplexer. It also has 20 digital to analog converters (DACs), 12 of which are the multiplying type. The AD-4 has 60 integrators, approximately 100 other amplifiers, 48 digital coefficient units, 68 servo-set potentiometers, 12 hand-set potentiometers, and 16 multipliers. The patchable logic consists of gates, flip-flops, registers, counters, etc.

The older analog equipment consists of 58 integrators, 102 other amplifiers, 250 hand-set potentiometers, 12 quarter-square multipliers, 15 servo-multipliers, 10 ten-segment diode function generators, 4 transport lag devices, etc.

3. DESCRIPTION OF MSBR SYSTEM

The proposed 1000 MW(e) MSBR plant¹ consists of a 2250 MW (t), graphite moderated, molten salt reactor, 4 shell and tube primary heat exchangers, and 16 shell and tube supercritical steam generators. The reactor core is made up of two zones. The central zone is ~14.4 ft in diameter and ~13 ft high with a primary salt fraction of 0.13. The outer zone is an annular region ~1.25 ft thick having a salt volume fraction of 0.37.

The molten salt fuel flows, at a constant rate, upward through the passages in the graphite core in a single pass and then to the tube side of four vertical, single pass, primary heat exchangers. The salt temperature entering the core is 1050°F and that at the core exit is 1300°F.

The heat generated in the primary salt in the core is transferred from the tube side of the primary heat exchangers to a countercurrent secondary salt passing through the shell side. The secondary salt flows in a closed secondary loop to the horizontal supercritical

steam generators. The four secondary loops (one for each primary heat exchanger) are independent of each other, with each loop flowing to four steam generators. The temperature of the secondary salt entering the steam generators is 1150°F and on leaving the steam generators its temperature is 850°F. The secondary salt flow rate can be changed by changing the pump speed.

The shell-and-tube supercritical steam generators are countercurrent, single-pass, U-tube exchangers ~77 ft in length and 18 in. in diameter. Feedwater enters the steam generators at 700°F and ~3770 psia pressure, when operating at design point steady state. At design point, the exit steam conditions are 1000°F and ~3600 psia pressure.

A flow diagram of the MSBR plant is shown in Fig. 1. The interesting physical constants are listed in Table 1, and the plant parameters are listed in Table 2.

4. DEVELOPMENT OF THE COMPUTER MODEL OF THE PLANT

As previously stated, the hybrid computer is used to simulate the steam generator in some detail. The older analog computer is used to simulate the rest of the system.

Since the programming techniques for the two above-mentioned computers are quite different in some respects, the hybrid model of the steam generator shall be discussed apart from the analog model of the rest of the system.

4.1 Steam Generator Model

The mathematical model of the steam generator consists of the differential equations expressing the conservation of mass, momentum, and energy of the water and secondary salt. In this model, the variation in the density of the secondary salt was neglected and

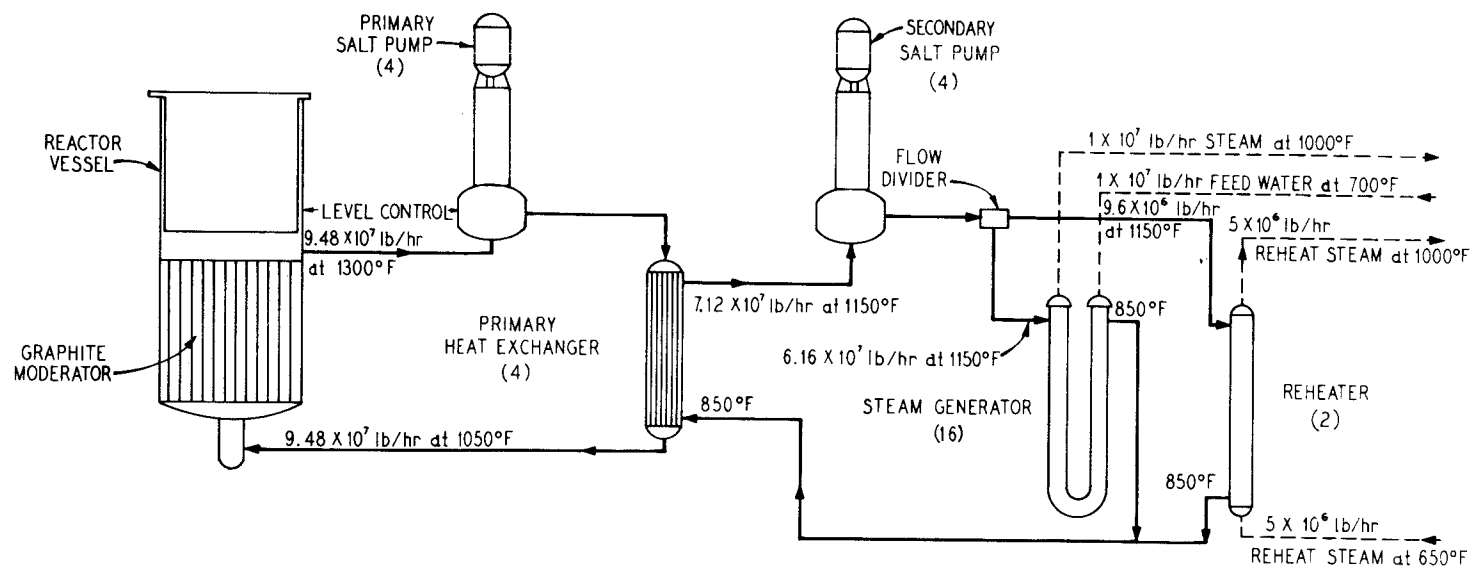

Fig. 1. Flow Diagram of MSBR Plant. The quantities shown are totals for the entire plant.

Table 1. Physical Constants

A. Properties of Materials

	C_p Btu lb ⁻¹ °F ⁻¹	ρ lb/ft ³	k Btu hr ⁻¹ °F ⁻¹ ft ⁻¹
Primary Salt	0.324	207.8 at 1175°F	-----
Secondary Salt	0.360	117 at 1000°F	-----
Steam			
726°F	6.08	22.7	-----
750°F	6.59	11.4	-----
850°F	1.67	6.78	-----
1000°F	1.11	5.03	-----
Hastelloy-N			
1000°F	0.115	548	9.39
1175°F	0.129	-----	11.6
Graphite	0.42	115	-----

B. Reactor Core

	Central Zone	Outer Zone
Diameter, ft	14.4	16.9
Height, ft	13	13
Salt volume fraction	0.132	0.37
Fuel	²³³ U	
Graphite-to-salt heat transfer coefficient, Btu hr ⁻¹ ft ⁻² °F ⁻¹	1065	
Temperature coefficients of reactivity, °F ⁻¹		
primary salt	-1.789 × 10 ⁻⁵	
graphite	+1.305 × 10 ⁻⁵	
Thermal neutron lifetime, sec	3.6 × 10 ⁻⁴	
Delayed neutron constants, $\beta = 0.00264$		
	λ_i (sec ⁻¹)	
	β_i	
	i	
	1	0.00102
	2	0.00162
		0.02446
		0.2245

C. Heat Exchangers

	Primary Heat Exchanger	Steam Generator	
		Steam Outlet	Feedwater Inlet
Length, ft	18.7		72
Triangular tube pitch, in.	0.75		0.875
Tube OD, in.	0.375		0.50
Wall thickness, in.	0.035		0.077
Heat transfer coefficients, Btu hr ⁻¹ ft ⁻² °F ⁻¹			
tube-side-fluid to tube wall	3500	3590	6400
tube-wall conductance	3963	1224	1224
shell-side-fluid to tube wall	2130	1316	1316

Table 2. Plant Parameters (Design Point)

Reactor Core

Heat flux	7.68×10^9 Btu/hr [2250 Mw(th)]	
Primary salt flowrate	9.48×10^7 lb/hr	
Steady state reactivity, ρ_0	0.00140	
External loop transit time of primary salt	6.048 sec	
	Zone I	Zone II
Heat generation	1830 Mw(th)	420 Mw(th)
Salt volume fraction	0.132	0.37
Active core volume	2117 ft ³	800 ft ³
Primary salt volume	279 ft ³	296 ft ³
Graphite volume	1838 ft ³	504 ft ³
Primary salt mass	58,074 lb	61,428 lb
Graphite mass	212,213 lb a	58,124 lb
Number of graphite elements	1466	553
Heat transfer area	30,077 ft ²	14,206 ft ²
Average primary salt velocity	~4.80 ft/sec	~1.04 ft/sec
Core transit time of primary salt	2.71 sec	12.5 sec

Primary Heat Exchanger (total for each of four exchangers, tube region only)

Secondary salt flow rate	1.78×10^7 lb/hr	
Number of tubes	6020	
Heat transfer area	11,050 ft ²	
Overall heat transfer coefficient	993 Btu hr ⁻¹ ft ⁻² °F ⁻¹	
Tube metal volume	30 ft ³	
Tube metal mass	16,020 lb	
	Primary salt (tube side)	Secondary salt (shell side)
Volume	57 ft ³	295 ft ³
Mass	11,870 lb	34,428 lb
Velocity	10.4 ft/sec	2.68 ft/sec
Transit time	1.80 sec	6.97 sec

Steam Generator (total for each of 16 steam generators, tube region only)

Steam flowrate	7.38×10^5 lb/hr	
Number of tubes	434	
Heat transfer area	4,102 ft ²	
Tube metal volume	22 ft ³	
Tube metal mass	12,203 lb	
	Steam (tube side)	Secondary salt (shell side)
Volume	20 ft ³	102 ft ³
Mass	235 lb	11,873 lb
Transit time	1.15 sec	9.62 sec
Average velocity	~62.8 ft/sec	7.50 ft/sec

hence only the conservation of energy is considered for the secondary salt. The equations, written in one space dimension, x , (the direction of water flow) and time, t , are as follows:

Conservation of mass (water)

$$\frac{\partial \rho}{\partial t} + \frac{\partial}{\partial x} (\rho v) = 0 ; \quad (1)$$

Conservation of momentum (water)

$$\frac{\partial(\rho v)}{\partial t} + \frac{\partial}{\partial x} (\rho v^2) = - \frac{k \partial p}{\partial x} - c v^2 ; \quad (2)$$

Conservation of energy (water)

$$\frac{\partial}{\partial t} (\rho h) + \frac{\partial}{\partial x} (\rho h v) = k_1 H (\theta - T) ; \quad (3)$$

Conservation of energy (salt)

$$\frac{\partial \theta}{\partial t} + V_s \frac{\partial \theta}{\partial x} = \frac{H k_2}{\rho_s c_p} (T - \theta) . \quad (4)$$

The equations of state for water:

$$T = T(p, h) ;$$

$$\rho = \rho(p, h) .$$

The definitions of the variables used in the above equations are as follows:

T = water temperature, °F,

ρ = water density, lb/ft³,

- v = water velocity, ft/sec,
 p = water pressure, lb/in²,
 c = coefficient of friction,
 k = constant used to make units consistent,
 h = specific enthalpy of water, Btu/lb,
 H = heat transfer coefficient, salt to water, Btu/sec-ft²-°F,
 k_1 = ratio of the surface area of a tube to the water volume in the tube, ft⁻¹,
 k_2 = ratio of the surface area of a tube to the salt volume adjacent to the tube, ft⁻¹,
 ρ_s = salt density (assumed constant), lb/ft³,
 c_p = specific heat of salt at constant pressure, Btu/lb-°F (assumed constant),
 θ = salt temperature, °F,
 V_s = salt velocity, ft/sec.

It was determined in previous work² that a continuous-space, discrete-time model is most satisfactory for this steam generator simulation. By a judicious choice of the direction of integration in space, of the various dependent variables, an initial value problem can be formed. Since the water enthalpy, h , and the water pressure, P , are known at the water entrance end of the exchanger (left end), these variables will be integrated from left to right. For the same reason, the water velocity (it can be calculated at the throttle) and the salt temperature will be integrated from right to left.

The critical flow at the throttle is expressed by the following nonlinear relationship among the system variables at a point just before the throttle:

$$\rho v = M \left(\frac{A_T}{A_{T,0}} \right) \left(\frac{p}{1 + b_T} \right),$$

where A_T is the instantaneous value of the throttle opening, $A_{T,0}$ the initial steady state value, M the critical flow constant, and b an empirical constant (assumed to be equal to 0 in this simulation).

$A_{T,0}$ is taken as 1.0 and A_T is varied as a function of time during transients.

By simplification of Eqs. (1), (2), (3), and (4), and using the backwards differencing scheme for the time derivative, the following ordinary differential equations are generated.

$$\frac{dp}{dx} = -\frac{\rho v}{k} \frac{dv}{dx} - \frac{cv^2}{k} - \frac{\rho}{k} \frac{(v - v_k)}{\Delta t};$$

$$\frac{dh}{dx} = \frac{1}{\rho v} [k_1 H(\theta - T)] - \frac{h - h_k}{v \Delta t};$$

$$\frac{dv}{dx} = -\frac{v}{\rho} \frac{dp}{dx} - \frac{\rho - \rho_k}{\rho \Delta t};$$

$$\frac{d\theta}{dx} = +\frac{Hk_2(T - \theta)}{\rho_s c_p v_s} - \frac{\theta - \theta_k}{v_s \Delta t}.$$

In the above equations, the nonsubscripted variables are the ones being iterated for the values at the end of the $(k + 1)$ time increment, while the variables with the k subscripts represent their values at the end of the k^{th} time increment. The time increment is represented by Δt .

Since the v and θ equations are being integrated from right to left, they must be transformed using a different space variable. Let $y = L - x$, where L is the total length of the steam generator in the x direction. The new v and θ equations become:

$$\frac{dv}{dy} = \frac{v(y)}{\rho} \frac{d\rho}{dy} + \frac{\rho - \rho_k}{\rho \Delta t} ;$$

$$\frac{d\theta}{dy} = \frac{Hk_2(T - \theta)}{\rho_s c_p V_s(y)} - \frac{\theta - \theta_k}{V_s(y) \Delta t} .$$

In the hybrid program developed from the above equations, the integrations are performed on the AD-4 analog computer. The digital computer calculates the terms of the differential equations, provides control for the calculation, and provides storage. The AD-4 patchable logic is used in the problem control circuitry as communication link-ages between the digital computer and the AD-4 analog computer. The patchable logic, along with BCD counters, is also used for problem timing and time synchronization between the digital computer and the AD-4 analog computer.

The thermodynamic properties of water are stored in the digital computer as two-dimensional tables. An interpolation routine is used to develop values from the numbers in the tables.

The calculational procedure for a time step, Δt , is as follows:

The current values of the water temperature, T , and water pressure, p , at the water entrance end (left end) of the steam generator are read and stored in the digital computer. The current value of the secondary salt temperature, θ , at the salt entrance

end (right end) of the steam generator is read from the continuous time analog model and is stored in the digital computer. The secondary salt velocity, V_s , and the throttle valve position, A_T , are also read from the continuous time analog model and their values are stored in the digital computer.

The terms of the dh/dx and dp/dx equations are calculated by the digital computer, using the values of the variables at the left end of the steam generator. The values of these terms as well as the values of the initial conditions of h and p are set on the coefficient devices representing them on the AD-4 analog computer. This coefficient device setting is implemented by a command from the digital computer. Upon a command from the digital computer, the h and p integrators on the AD-4 computer start integrating in x . While the integration is proceeding, the digital computer is calculating the differential equation terms for the next space node (a space node is 1 foot long). When the digital calculations have been completed, the digital computer interrogates the AD-4 computer, through the patchable logic, as to whether or not its integrations have reached the end of the node. Upon getting an affirmative answer, the digital computer reads and stores the values of p and h from their integrators on the AD-4 computer. These integrators are in the hold mode at this time, having been placed in this mode by a logic signal from a BCD counter signifying that the end of a node has been reached. The digital computer sets the coefficient devices to their newly calculated values and starts the integrators to integrating over the next node. This procedure is repeated for each spatial node until the right-hand end of the steam generator is reached.

With a procedure identical to that above, and with the current values of p and h , the salt temperature and water velocity differential equations are integrated from right to left. When the right to left integrations have proceeded to the left boundary, they are halted.

The left to right integration of p and h is repeated, using the current values of p , h , v , and θ . The right to left integration of v and θ is repeated, etc., until the convergence is satisfactory.

In actuality, the convergence was experimentally determined to be satisfactory after five iterations and this number was used in the program. A definite number of iterations is dictated by the fact that time synchronization must be maintained between the discrete time steam generator model and the continuous time model of the remainder of the system.

The time allotted for a time step, Δt , is set on a BCD counter such that the counter will give out a logic signal signifying the end of the time step.

At the end of the fifth iteration, the digital computer starts interrogating the AD-4 computer to see if the allotted Δt time has elapsed. When the digital computer gets an affirmative answer, it reads and stores the current values of the appropriate variables from the continuous time model and another time step calculation is started. Of course, this procedure is repeated for as long as the simulation is in operation.

It was experimentally determined that the calculational stability was not good for time steps very much less than 0.5 sec. As a consequence, a Δt of 0.5 sec was used.

It was also experimentally determined that the completion of five iterations required in excess of 8 sec. As a result, 10 sec of computer time was made the equivalent of 0.5 sec of real system time. The continuous time model was time scaled accordingly (machine time = 20 times real system time). The sampling rate of the continuous time model was, therefore, once each 10 sec. This means that the values of variables generated in the continuous

time model and used in the discrete time steam generator model are sampled once each 10 sec of machine time, which corresponds to 0.5 sec in real system time. In a like manner, the variables generated in the discrete time steam generator model and used in the continuous time model of the remainder of the system are updated once each 10 sec in machine time.

The Fortran source program for the digital portion of the simulation is included as Appendix B. The AD-4 analog and patchable logic circuits are shown in Fig. 2.

4.2 The Analog Computer Model of the System Exclusive of the Steam Generator

The computer model of the reactor, primary heat exchanger, piping, etc., is a continuous time, lumped parameter, model similar to those traditionally used on analog computers. The heat flow model is shown in Fig. 3.

4.2.1 The Nuclear Kinetics Model

Experience has shown that for the rather mild transients for which this model is intended, a two-delay-group nuclear kinetics model is adequate.³ That this is a circulating fuel reactor adds to the complication of the model.

The nuclear kinetics equations are as follows:

$$\frac{dP}{dt} = \frac{(\rho - \beta)}{\Lambda} P + \lambda_1 C_1 + \lambda_2 C_2 ;$$

$$\frac{dC_1}{dt} = \frac{\beta_1}{\Lambda} P - \lambda_1 C_1 - \frac{C_1}{\tau_c} + \frac{e^{-\lambda_1 \tau_1}}{\tau_c} C_1(t - \tau_1) ;$$

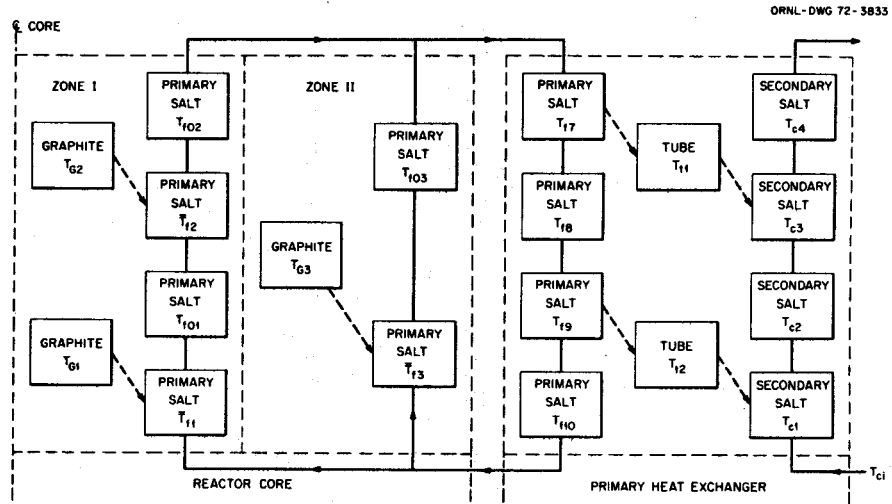

Fig. 2. Lumped-Parameter Model of MSBR Core and Heat Exchanger.

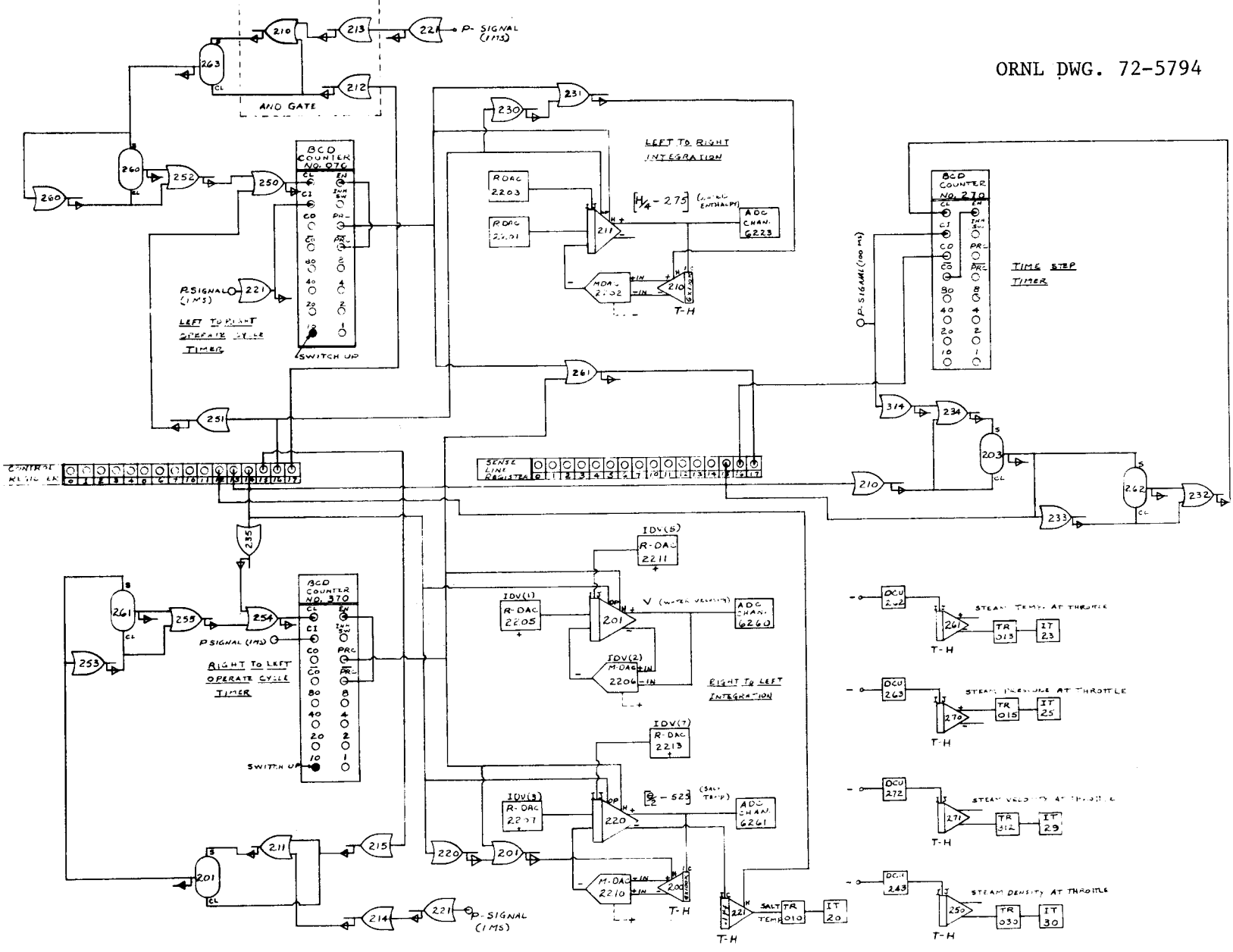

Fig. 3. Patching Schematics for the AD-4 Computer.

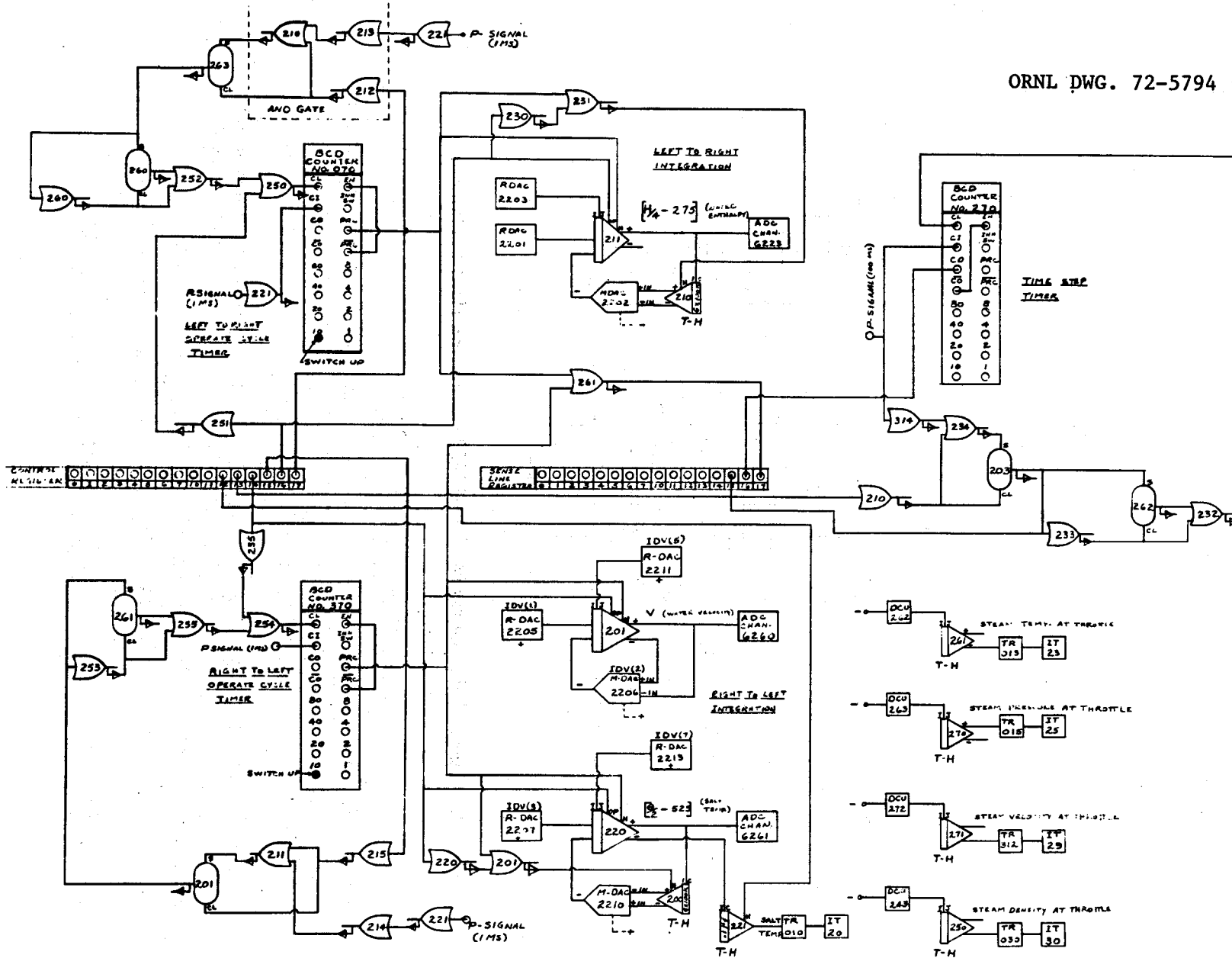

Fig. 3. Patching Schematics for the AD-4 Computer.

$$\frac{dC_2}{dt} = \frac{\beta_2}{\Lambda} P - \lambda_2 C_2 - \frac{C_2}{\tau_c} + \frac{e^{-\lambda_2 \tau_1}}{\tau_c} C_2(t - \tau_1) ; \quad (9)$$

where

- P = the nuclear power level,
 ρ = reactivity,
 β = total delayed neutron fraction,
 Λ = mean neutron lifetime,
 λ_1 = decay constant for delayed neutron group No. 1,
 C_1 = delayed neutron precursor concentration of group No. 1,
 λ_2 = decay constant for delayed neutron group No. 2,
 C_2 = delayed neutron precursor concentration of group No. 2,
 β_1 = delayed neutron fraction for group No. 1,
 β_2 = delayed neutron fraction for group No. 2,
 τ_c = reactor core resident time of the circulating fuel,
 τ_l = resident time of the circulating fuel in the loop external to the core.

In the model, the fuel salt flow rate is assumed constant; therefore, τ_c and τ_l are constants.

The development of the computer model of the reactor kinetics from the above equations is shown in some detail in Appendix A.

4.2.2 The Reactor Core Heat Transfer Model

In the simulation model, core zone 1 contains two graphite lumps, and core zone 2 contains one graphite lump. There are two fuel salt lumps adjacent to each graphite lump. The outlet temperature of the first adjacent fuel salt lump (in the direction of salt flow) is used as the average fuel salt temperature in the equations describing the heat transfer between a graphite lump and the fuel salt lumps adjacent to it.

The typical heat balance equation for core graphite heat generation and heat transfer is as follows:

$$M_{gi} C_{pg} \frac{dT_{gi}}{dt} = h_{fg} A_{gi} (\bar{T}_{fi} - T_{gi}) + K_{gi} P ,$$

where

M_{gi} = the mass of graphite in the i^{th} lump, lb,

C_{pg} = graphite heat capacity, Btu/lb-°F,

T_{gi} = the average graphite temperature in the i^{th} graphite lump, °F,

h_{fg} = the overall heat transfer coefficient between the graphite and the fuel salt,
Btu/ft²-°F-sec,

A_{gi} = the heat transfer area between the graphite in the i^{th} lump and the fuel adjacent to it, ft²,

\bar{T}_{fi} = the average temperature of the fuel salt adjacent to the graphite in the i^{th} graphite lump, °F,

K_{gi} = the fraction of total fission power that is produced in the i^{th} graphite lump,

P = total fission power produced by the reactor, Btu/sec.

The typical heat balance equations for the generation and transfer of heat in the core fuel adjacent to the i^{th} graphite lump are:

$$M_{fi} C_{pf} \frac{d\bar{T}_{fi}}{dt} = F_i C_{pf} (T_{i, in} - \bar{T}_{fi}) + h_{fg} A_{fi} (T_{gi} - \bar{T}_{fi}) + K_{fi} P$$

and

$$M_{fi} C_{pf} \frac{dT_{foi}}{dt} = F_i C_{pf} (\bar{T}_{fi} - T_{foi}) + h_{fg} A_{fi} (T_{gi} - \bar{T}_{fi}) + K_{fi} P ,$$

where

M_{fi} = one-half the mass of the fuel salt adjacent to the graphite in the i^{th} graphite lump, lb,

C_{pf} = fuel salt heat capacity, Btu/lb-°F,

F_i = fuel salt mass flow rate adjacent to the i^{th} graphite lump, lb/sec,

$T_{i, in}$ = the fuel salt temperature as it enters the i^{th} graphite lump, °F,

A_{fi} = one-half the heat transfer area of the i^{th} graphite lump, ft²,

K_{fi} = one-half the fraction of the total fission power that is generated in the fuel salt adjacent to the i^{th} graphite lump,

T_{foi} = the fuel salt temperature at the salt discharge end of the i^{th} graphite lump, °F.

The detailed development of these equations into the time and magnitude scaled computer equations is shown in Appendix A.

4.2.3 Piping Lag Equations

The piping lags between the reactor core and the primary heat exchanger shall be considered the same in both directions. They will be treated as first order lags, implying perfect mixing. The resulting equations are as follows:

$$\frac{dT_{xin}}{dt} = \frac{1}{\tau_x} (T_{RO} - T_{xin}) ,$$

and

$$\frac{dT_{fin}}{dt} = \frac{1}{\tau_x} (T_{f10} - T_{fin}) ,$$

where

T_{xin} = fuel salt temperature at the primary heat exchanger inlet, °F,

τ_x = fuel salt residence time in piping between the reactor core and the primary heat exchanger, sec,

T_{RO} = average fuel salt temperature at reactor core outlet, °F,

T_{fin} = fuel salt temperature at reactor core inlet, °F,

T_{f10} = fuel salt temperature at the primary heat exchanger outlet, °F.

4.2.4 Primary Heat Exchanger Equations

For the simulation, the primary heat exchanger is broken up into two primary salt lumps, two tube metal lumps, and two secondary salt lumps. Each of the primary and secondary salt lumps is divided into two identical half lumps, and the outlet temperature of the first half lump is used as the average temperature in the heat transfer equations.

Since the secondary salt mass flow rate can be changed by changing the circulating pump speed, the heat transfer coefficient between the tube wall and the secondary salt will vary with salt mass flow rate. As an approximation, the heat transfer coefficient was considered to be proportional to the secondary salt mass flow rate raised to the 0.6 power.

The typical heat balance equations for the primary salt in the primary heat exchanger are as follows:

$$M_{fi} C_{pf} \frac{dT_{fi}}{dt} = F_x C_{pf} [T_{f(i-1)} - T_{fi}] + h_{fp} A_{fx} (T_{tj} - T_{fi})$$

and

$$M_{f(i+1)} C_{pf} \frac{dT_{f(i+1)}}{dt} = F_x C_{pf} [T_{fi} - T_{f(i+1)}] + h_{fp} A_{fx} (T_{tj} - T_{fi}) ;$$

where

$i = 7$ when $j = 1$, and $i = 9$ when $j = 2$,

$M_{fi} = M_{f(i+1)}$ = one-fourth the total primary salt mass in the primary heat exchanger, lb,

C_{pf} = the heat capacity of the primary salt, Btu/lb. $^{\circ}$ F,

F_x = primary salt mass flow rate in the primary heat exchanger, lb/sec,

h_{fp} = the overall heat transfer coefficient between the primary salt and the heat exchanger tube wall, Btu/ft²-sec- $^{\circ}$ F,

A_{fx} = one-fourth the total heat transfer area between the primary salt and the primary heat exchanger tubes, ft²,

T_{tj} = the average temperature of the tube wall metal in the j^{th} lump, $^{\circ}$ F.

The heat balance equations for the primary heat exchanger tube metal are the following:

$$M_T C_T \frac{dT_{t1}}{dt} = h_{fp} A_T (T_{f7} - T_{t1}) - h_{TC} A_T (T_{t1} - T_{C3})$$

and

$$M_T C_T \frac{dT_{t2}}{dt} = h_{fp} A_T (T_{f9} - T_{t2}) - h_{TC} A_T (T_{t2} - T_{C1}) ;$$

where

M_T = mass of tube metal in lump number one = one-half the total tube metal mass in the primary heat exchanger, lb,

C_T = the heat capacity of the tube metal in the primary heat exchanger, Btu/lb-°F,

T_{t1} = the average temperature of the tube metal in lump number one, °F,

A_T = the heat transfer area between the primary salt and the tube walls in any tube metal lump, ft²,

h_{TC} = the overall heat transfer coefficient between the secondary salt and the tube walls in the primary heat exchanger, Btu/ft²-sec-°F (this is a variable in the equation),

T_{C3} = the secondary salt temperature at the outlet of secondary salt lump three, °F.

The heat balance equations for the secondary salt in the primary heat exchanger are the following:

$$M_c C_{pc} \frac{dT_{c1}}{dt} = F_c C_{pc} (T_{cin} - T_{c1}) + h_{TC} A_c (T_{t2} - T_{c1}) ;$$

$$M_c C_{pc} \frac{dT_{c2}}{dt} = F_c C_{pc} (T_{c1} - T_{c2}) + h_{Tc} A_c (T_{t2} - T_{c1}) ;$$

$$M_c C_{pc} \frac{dT_{c3}}{dt} = F_c C_{pc} (T_{c2} - T_{c3}) + h_{Tc} A_c (T_{t1} - T_{c3}) ;$$

and

$$M_c C_{pc} \frac{dT_{c4}}{dt} = F_c C_{pc} (T_{c3} - T_{c4}) + h_{Tc} A_c (T_{t1} - T_{c3}) ;$$

where

M_c = one-fourth the total secondary salt mass in the primary heat exchanger, lb,

C_{pc} = the heat capacity of the secondary salt, Btu/lb-°F,

T_{ci} = the temperature of the secondary salt at the outlet of the i^{th} secondary salt lump, °F,

F_c = the mass flow rate of the secondary salt in the primary heat exchanger, lb/sec
(this is a variable),

T_{cin} = the secondary salt temperature as it enters the primary heat exchanger, °F,

A_c = one-fourth the total heat transfer area between the secondary salt and the primary heat exchanger tubes, ft²,

h_{Tc} = the overall heat transfer coefficient between the metal tubes and the secondary salt in the primary heat exchanger (this is a variable and proportional to the secondary salt mass flow rate raised to the 0.6 power).

The heat balance equations for the secondary salt in the primary heat exchanger are as follows:

$$M_{ci} C_{pc} \frac{dT_{ci}}{dt} = F_c C_{pc} [T_{c(i-1)} - T_{ci}] + h_{Tc} A_c (T_{tj} - T_{ci})$$

and

$$M_{ci} C_{pc} \frac{dT_{c(i+1)}}{dt} = F_c C_{pc} [T_{ci} - T_{c(i+1)}] + h_{Tc} A_c (T_{tj} - T_{ci}) ;$$

where

$i = 1$ when $j = 2$, and $i = 3$ when $j = 1$,

M_{ci} = one-fourth the secondary salt mass in the primary heat exchanger, lb,

C_{pc} = the heat capacity of the secondary salt, Btu/lb-°F,

F_c = secondary salt mass flow rate in the primary heat exchanger, lb/sec (this is a variable in the simulation),

T_{ci} = average secondary salt temperature in the i^{th} lump, °F,

A_c = one-fourth the total heat transfer area between the secondary salt and the tube walls in the primary heat exchanger, ft².

The development of the computer equations for the primary heat exchanger is shown in Appendix A.

The patching diagram for the old analog computer is shown in Fig. 4.

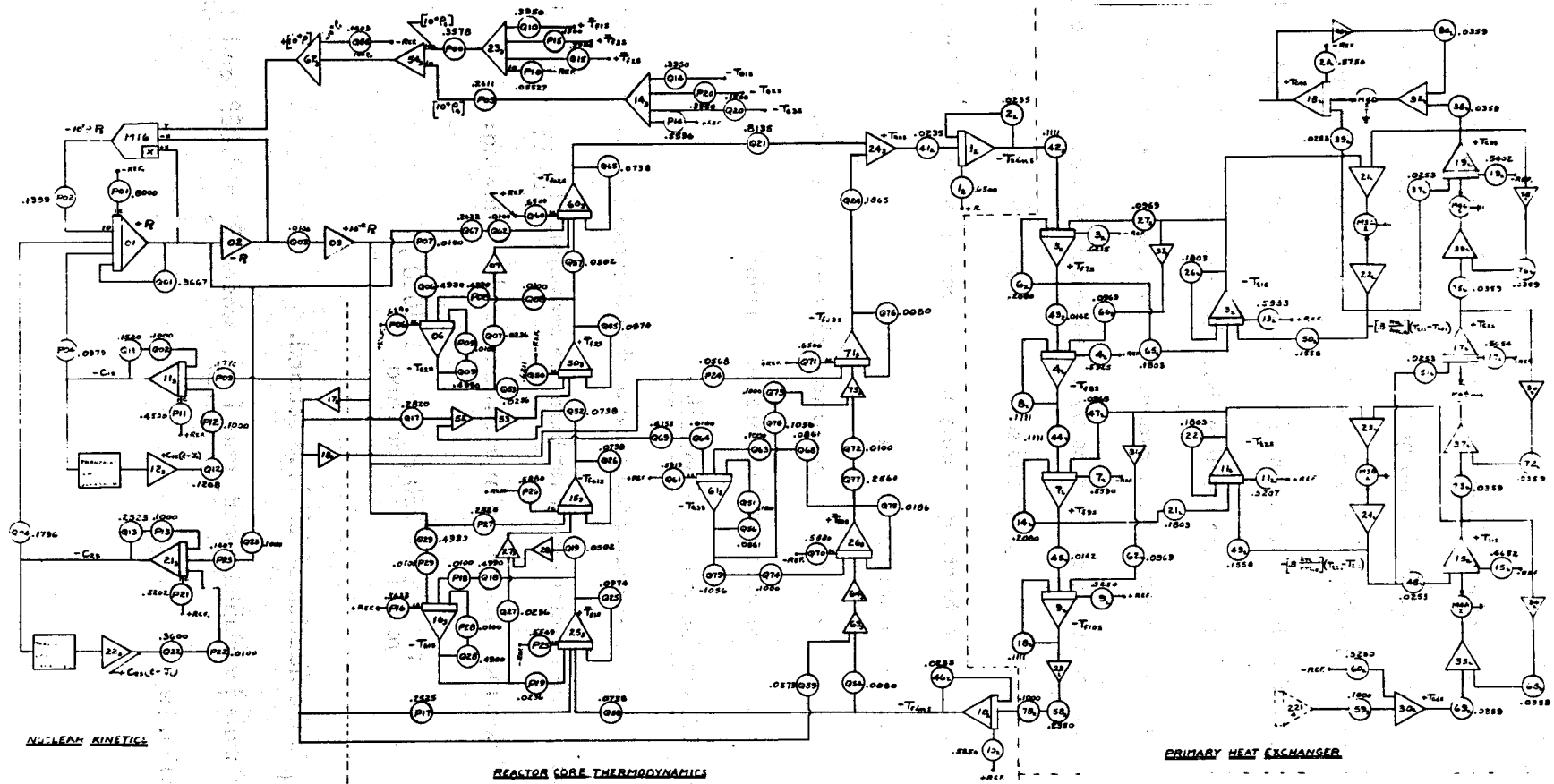

Fig. 4. Patching Schematics for the Old Analog Computer.

4.2.5 System Controllers

Probably the most important thing to be considered in the automatic control of the system is that of avoiding freezing of the primary or secondary salt. Of course, the steam conditions at the turbine throttle must also be closely controlled. Previous studies⁴ have shown that it is impossible to realize both of the above objectives without adding auxiliary devices to the system. Two possible solutions have been suggested. One is to add a secondary salt bypass line and mixing valve around the primary heat exchanger so that a controlled portion of the secondary salt can be bypassed while the steam temperature at the throttle is controlled. The other proposed scheme is to use the salt system as it is and to allow the steam temperature to change freely in the steam generator and then attemperate it to the desired temperature for the turbine.

In this simulation, the steam attemperation scheme was assumed.

Three controllers were incorporated into the simulation.

4.2.5.1 Reactor Outlet Temperature Controller

This controller was essentially the same as that described by W. H. Sides, Jr., in ORNL-TM-3102.⁴ The reactor outlet temperature set point, $T_{ro\ SET}$, was proportional to the plant load demand. The set point equation was the following:

$$T_{ro\ SET} = 250 P_{demand} + 1050 ,$$

where P_{demand} is the fraction of full load demand.

Since the scaled variables are P_s and T_{ros} , where $P_s = 0.08P$ and $T_{ros} = \frac{1}{20} T_{ro}$, the scaled equation is:

$$T_{ros\ SET} = 0.15625 P_{s\ demand} + 52.50 .$$

The reactor power level set point was proportional to the difference between the outlet temperature set point and the measured reactor inlet temperature. The scaled equation is as follows:

$$P_{s\ SET} = 6.4(T_{ros\ SET} - T_{fins}) .$$

A reactor power level error was obtained by taking the difference between the power set point value and the measured value (from neutron flux). The resulting equation is

$$\epsilon = P_s - P_{s\ SET} .$$

This power level error, ϵ , was the input signal to a control rod servo described by the second order transfer function:

$$T(S) = \frac{G\omega^2}{S^2 + 2S\omega S + \omega^2} = \frac{O(S)}{\epsilon(S)} ,$$

where G is the controller gain, ω is the bandwidth, S is the damping factor, and $O(S)$ is the Laplace transform of the servo output, dp_c/dt .

In this simulation, the bandwidth was 5 Hz and the damping factor was 0.5. The gain of the controller, G , was such that for $|\epsilon| = 1\%$ of full power, the control rod reactivity change rate was about 0.01%/sec; that is,

$$\frac{d\rho_c}{dt} = 0.01\%/sec ,$$

where ρ_c is the control reactivity.

For power level errors in excess of 1% of full power, the rate of change of reactivity was limited to 0.01%/sec.

4.2.5.2 Secondary Salt Flow Controller

The secondary salt flow rate controller forced the flow rate to follow the load demand in a programmed manner. The programmed flow rate is that required to prevent the salt systems from approaching their respective freezing points. The program was deduced from a series of steady state calculations performed by W. H. Sides, Jr.⁴

Since, in the simulation, we are assuming that the salt density is constant, a change in the salt velocity is equivalent to a change in the salt flow rate. The programmed equation is

$$\text{velocity fraction} = 0.875 \text{ load fraction} + 0.125 .$$

In the simulation, a velocity fraction of one is equal to 80 volts and a load fraction of one is also equal to 80 volts. The equation becomes:

$$\text{velocity fraction} = 0.875 \text{ load fraction} + 10.0 .$$

4.2.5.3 Steam Pressure Controller

The steam pressure controller was used to control the steam pressure at the turbine throttle. The pressure sensor was assigned a time lag with a time constant of 0.1 sec. The pressure was changed by changing the speed of the feedwater pump.

The simple proportional controller equation is

$$G_p (P_r \text{ SET} - P_r) = \frac{dP_r}{dt} .$$

The gain, G_p , was such that a pressure error of 1% of design point pressure would cause the inlet pressure to be changed at a rate of 3.6 psi/sec.

The controllers were simulated on the old analog computer. The wiring schematics are shown in Fig. 5.

5. RESULTS OF SIMULATION EXERCISES

The severity of the transients that can be run on this simulation model is somewhat limited by the nature of the steam generator model (the calculational time step is 0.5 sec).

The transients were run in order to determine the system response times, the rates of change of temperatures, and whether the salt temperatures approached the freezing points.

The conditions and results for the transients that were run were as follows:

1. Steady State Part Loads

The purpose of these computer runs was to determine the values of the system variables when operating at various fractions of full load. The system controllers were in operation as the load demand was changed from one level to another.

The load demand was changed by changing the turbine throttle opening. The area of the throttle opening was changed in increments of 10% of design point throttle area. The range of throttle openings covered was from the design point opening down to 30% of design point opening. The percentage of throttle area turned out to be very nearly the same as the percentage of load for each case.

Probably the thing of most interest was whether either the primary or secondary salt approached its respective freezing point for these part load operations. The results of interest are shown in Fig. 6.

It is evident that the temperatures in both salt systems are well above their respective freezing points (930°F for the primary salt and 725°F for the secondary salt).

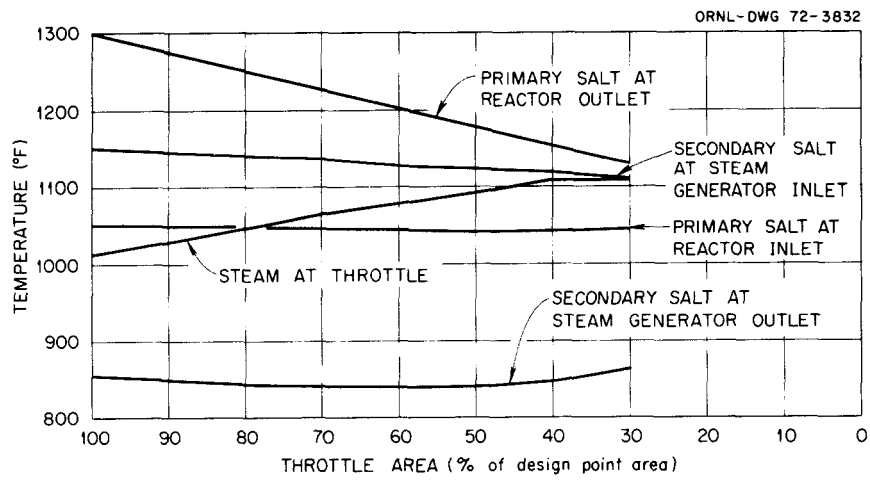

Fig. 6. Temperatures in the MSBR System for Part Load Operation.

2. Rapid Change in Load Demand

A number of fast changes in load demand were run in order to observe the resulting system response. The rates of change of the system temperatures were of interest. The secondary salt temperature at the steam generator outlet changed at a rate of approximately $4.5^{\circ}\text{F}/\text{sec}$ for the case when the load demand was ramped from full load to 40% full load in $1\text{-}2/3$ sec. The results of the case where the load demand was ramped from 100% to 40% in 3 sec are shown in Fig. 7.

3. Changes in Secondary Salt Flow Rate

In order to observe the system response to a change in secondary salt flow rate, the secondary salt flow rate was reduced from full flow to 75% of full flow on a 5-sec ramp. The results are shown in Fig. 8.

4. Step Changes in Nuclear Fission Power Level

Step increases and decreases in nuclear fission power were implemented in order to observe the system response to same. The system response to a step change in nuclear fission power from full power to 75% power is shown in Fig. 9.

5. Changes in Reactivity

As a rough approximation of inserting two safety rods (each worth -1.5% in $\delta k/k$), -3% $\delta k/k$ was ramped in in 15 sec. The results are shown in Fig. 10.

As a rough approximation of a fuel addition accident, $+0.2\%$ $\delta k/k$ was ramped in in 1.5 sec. The results are shown in Fig. 11.

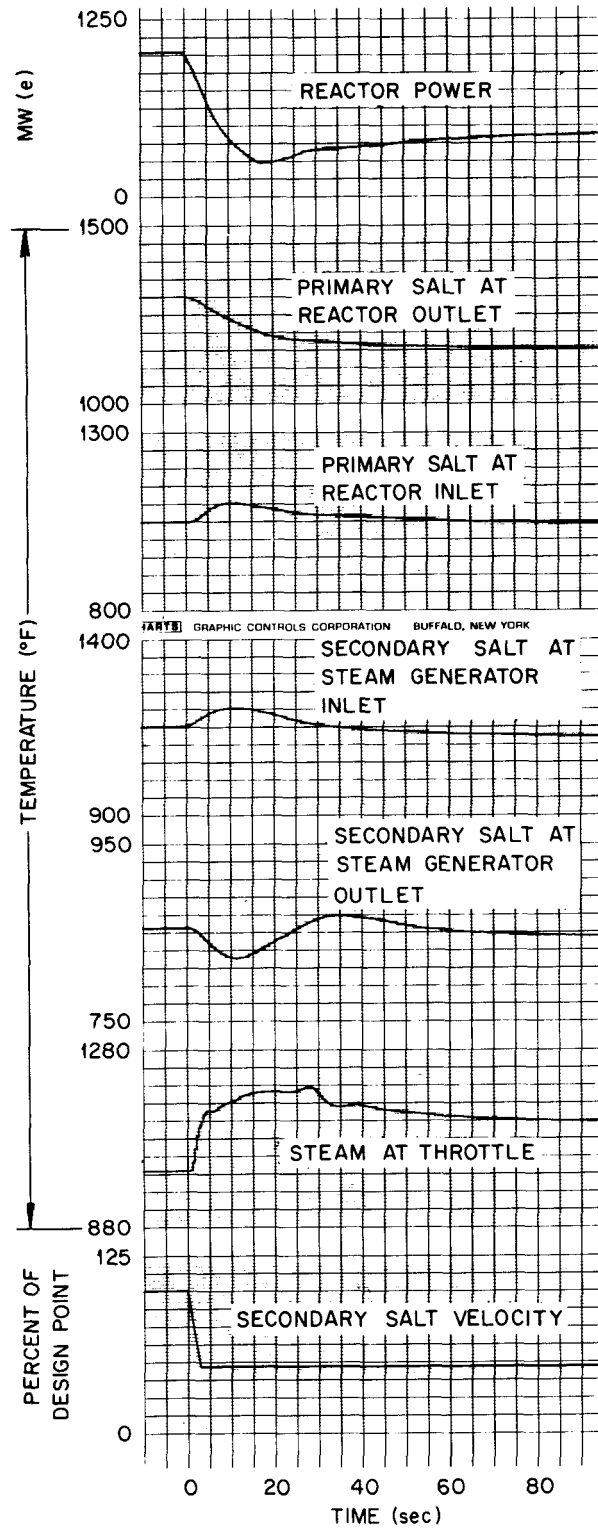

Fig. 7. System Response to a Ramp Change in Load Demand from 100 to 40% in 3 sec.

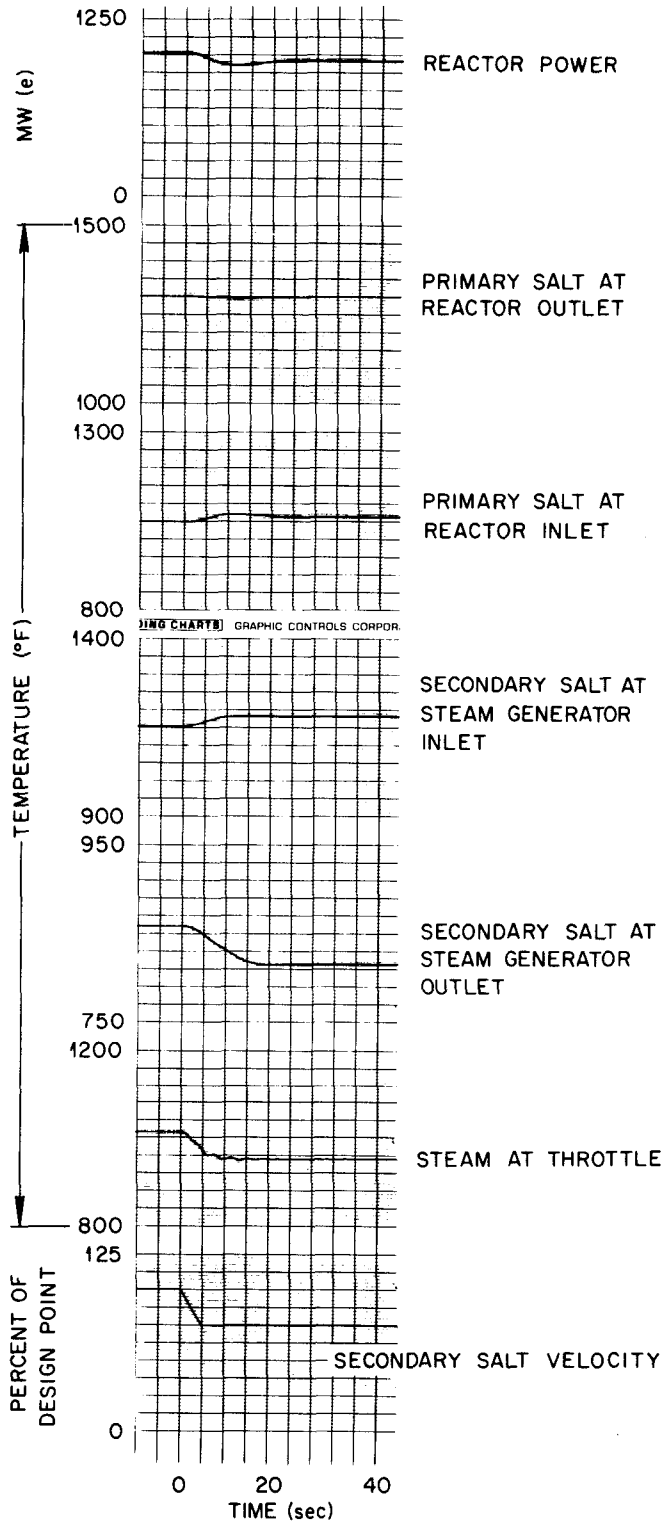

Fig. 8. System Response to a Ramp Change in Secondary Salt Flow Rate from 100 to 75% in 5 sec.

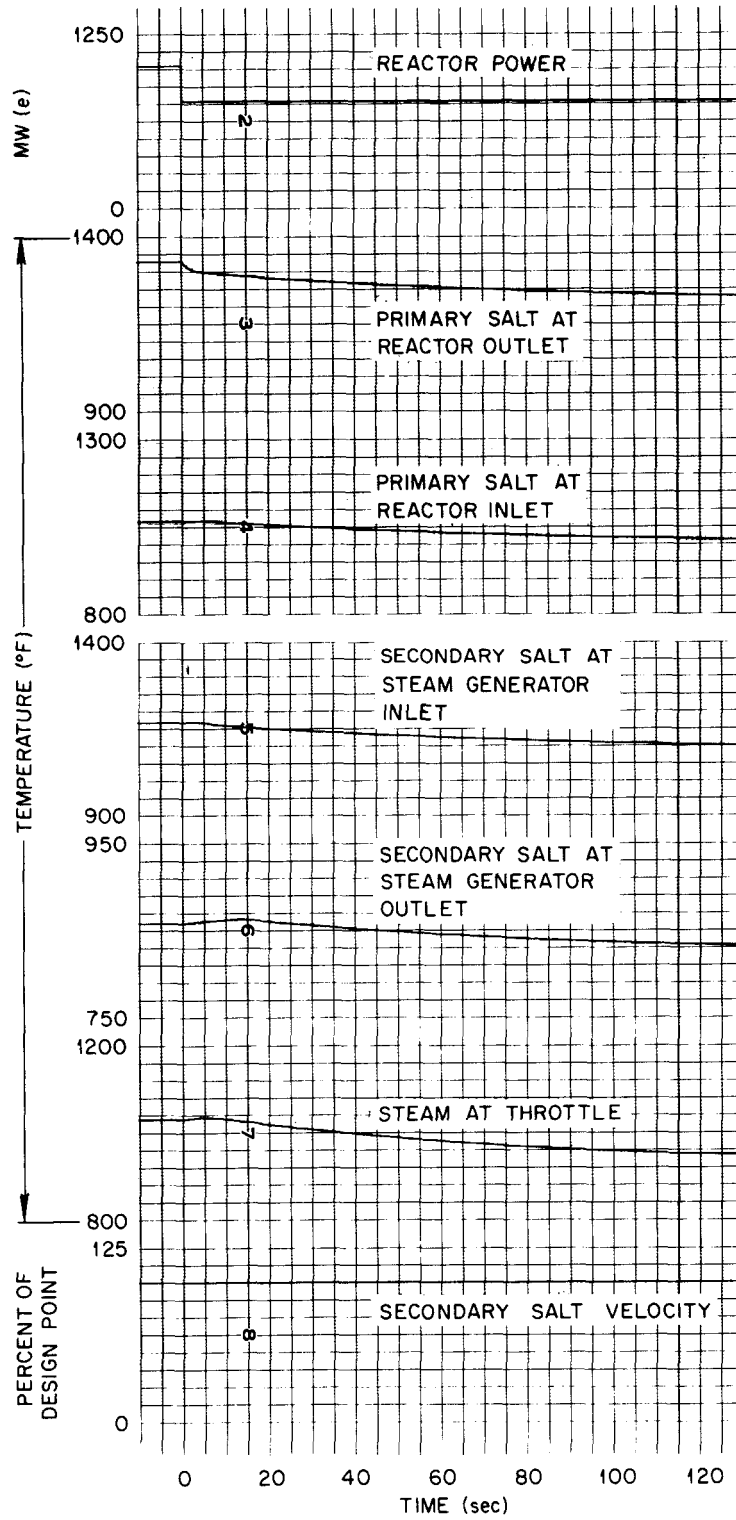

Fig. 9. System Response to a Step Change in Nuclear Fission Power from 100 to 75%.

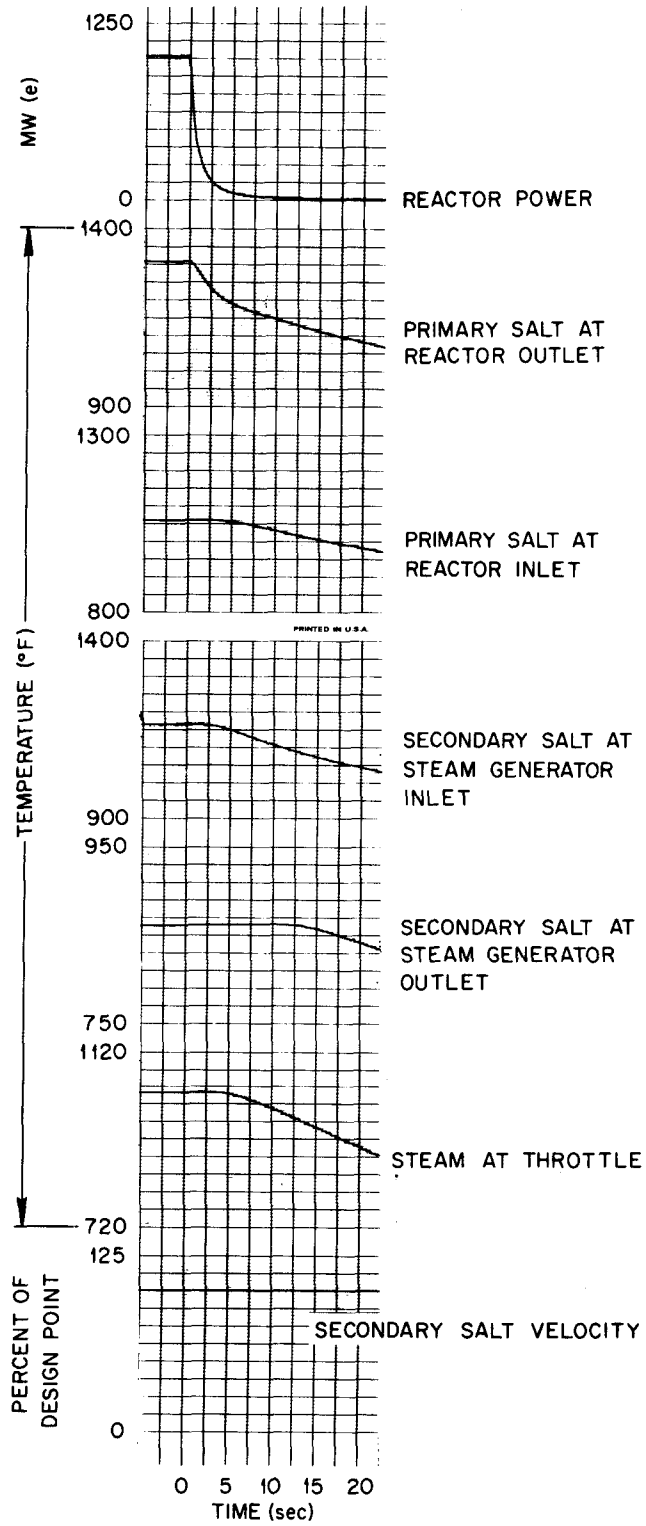

Fig. 10. System Response to Insertion of Two Safety Rods.

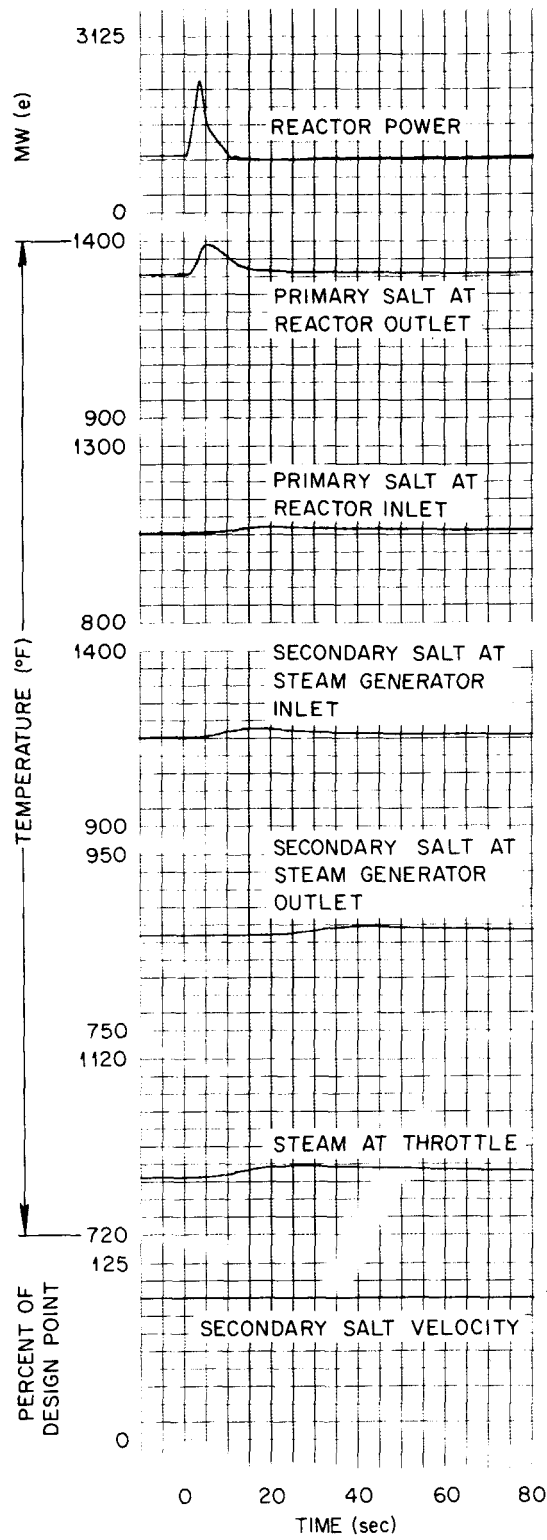

Fig. 11. System Response to a Ramp addition of 0.2% $\delta k/k$ in 1.5 sec.

6. Uncontrolled Increasing Load Demand

An uncontrolled load demand accident was simulated by increasing the load demand from 30% load to full load at a rate of 40% full load per minute (ten times normal rate).

The results are shown in Fig. 12.

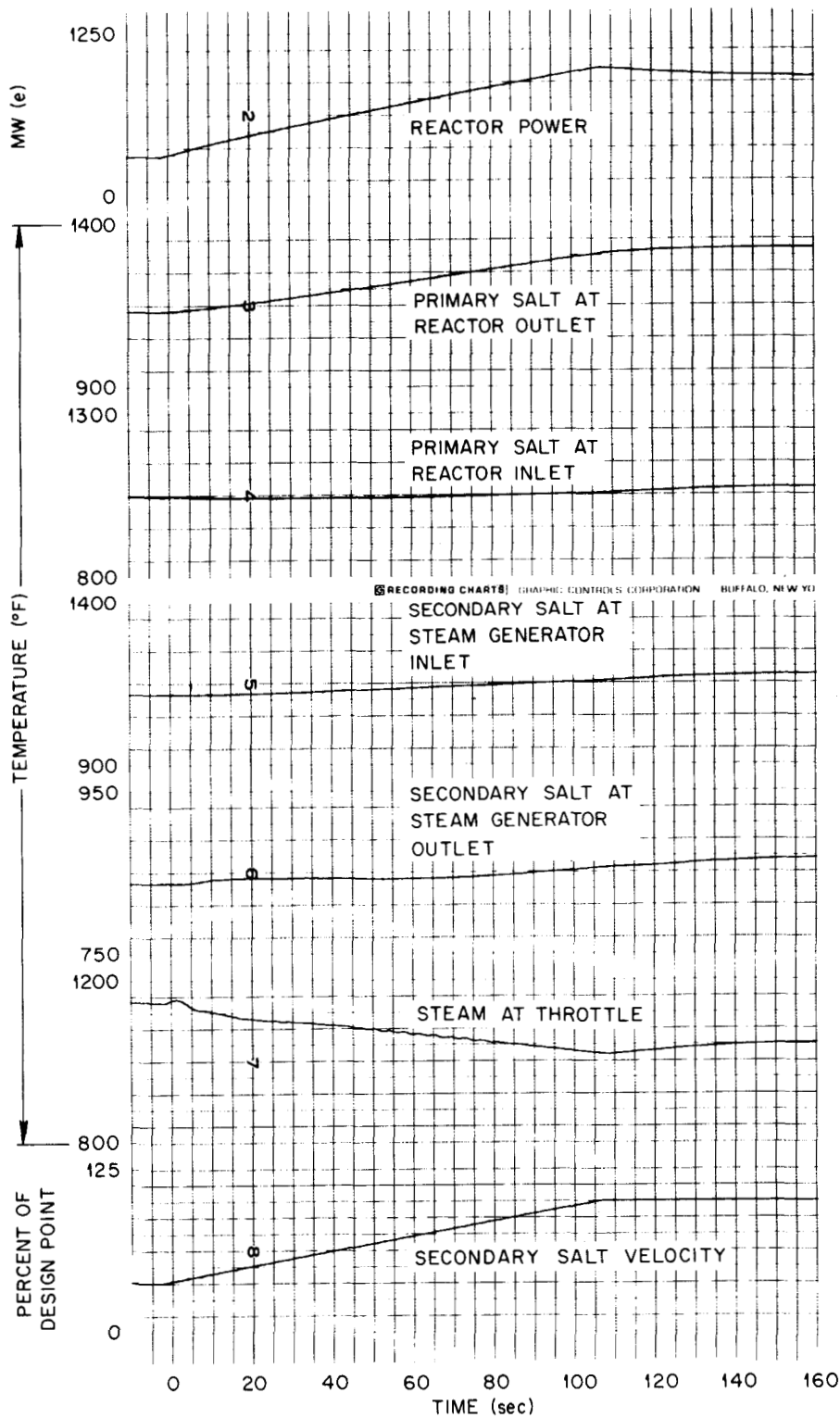

Fig. 12. System Response to a Ramp Change in Load Demand from 30 to 100% Load at a Rate of 40% of Full Load per min.

References

1. Robertson, R. C., et al., Conceptual Design of a Single-Fluid Molten Salt Breeder Reactor, ORNL-4541 (June 1971).
2. Sanathanan, C. K., and Sandberg, A. A., University of Illinois, Chicago, Ill., and Clark, F. H., Burke, O. W., and Stone, R. S., ORNL, Transient Analysis and Design Evaluation of a Once-Through Steam Generator with the Aid of a Hybrid Computer.
3. MacPhee, J., The Kinetics of Circulating Fuel Reactors, Nucl. Sci. Eng. 4, 588-97 (1958).
4. Sides, W. H., Jr., Control Studies of a 1000-Mw(e) MSBR, ORNL-TM-2927 (May 1970).
Sides, W. H., Jr., MSBR Control Studies: Analog Simulation Program, ORNL-TM-3102 (May 1971).
Sides, W. H., Jr., MSR-70-56, August 21, 1970.

7. APPENDIX

7.1 A: Development of Computer Model

7.1.1 The All-Analog Model

The all-analog model represents the nuclear reactor, the primary heat exchanger, and the interconnecting piping. The primary, or fuel, salt flows at a constant rate; and the secondary, or coolant, salt flows at a variable rate. The heat transfer coefficient between the primary heat exchanger tubes and the secondary salt was considered to be proportional to the secondary salt mass flow rate raised to the .6 power. The piping time lag for the primary salt between the reactor and the primary heat exchanger is 2.124 sec. The same time lag was used for the return flow to the reactor.

The reactor kinetics model has two weighted groups of delayed neutrons.³

7.1.1.1 Nuclear Kinetics Model

$$\frac{dP}{dt} = \frac{(\rho - \beta)}{\Lambda} P + \lambda_1 C_1 + \lambda_2 C_2 ;$$

$$\frac{dC_1}{dt} = \frac{\beta_1}{\Lambda} P - \lambda_1 C_1 - \frac{C_1}{\tau_c} + \frac{e^{-\lambda_1 \tau_l}}{\tau_c} C_1(t - \tau_l) ;$$

$$\frac{dC_2}{dt} = \frac{\beta_2}{\Lambda} P - \lambda_2 C_2 - \frac{C_2}{\tau_c} + \frac{e^{-\lambda_2 \tau_l}}{\tau_c} C_2(t - \tau_l) .$$

Using the values listed in Tables 1 and 2 and Fig. 1, the above equations become:

$$\frac{dP}{dt} = \frac{\rho}{0.00036} P - \frac{0.00264}{0.00036} P + 0.02446C_1 + 0.2245C_2 ;$$

$$\frac{dP}{dt} = 2.777 \times 10^3 \rho P - 7.333P + 0.02446C_1 + 0.2245C_2 ;$$

$$\frac{dC_1}{dt} = \frac{0.00102}{0.00036} P - 0.02446C_1 - \frac{1}{3.57} C_1 + \frac{e^{-(0.02446)(6.05)}}{3.57} C_1(t - \tau_1) ;$$

$$\frac{dC_1}{dt} = 2.8333P - 0.30456C_1 + 0.2416C_1(t - \tau_1) ;$$

$$\frac{dC_2}{dt} = \frac{0.00162}{0.00036} P - 0.2245C_2 - \frac{1}{3.57} C_2 + \frac{e^{-(0.2245)(6.05)}}{3.57} C_2(t - \tau_1) ;$$

$$\frac{dC_2}{dt} = 4.5P - 0.50455C_2 + 0.07204C_2(t - \tau_1) .$$

Use $P = 1000 \text{ MW(e)}$ at steady state, design point and calculate the design point values for C_1 and C_2 . At steady state, design point:

$$\frac{dC_1}{dt} = 0 = 2.8333(1000) - 0.30456C_1(0) + 0.2416C_1(0) ,$$

since, at steady state, $C_1(0) = C_1(t - \tau_1)(0)$.

$$C_1(0) = 45,000 \text{ MW} .$$

Likewise:

$$\frac{dC_2}{dt} = 0 = 4.5(1000) - 0.50455C_2(0) + 0.07204C_2(0) ;$$

$$C_2(0) = 10,404 \text{ MW} .$$

Since we do not expect to use the model to go to power levels very much exceeding 1000 MW(e), we shall use the calculated values of $C_1(0)$ and $C_2(0)$ as indicators for purposes of magnitude scaling C_1 and C_2 . Let

$$C_{1(\text{max.})} = 1 \times 10^5 \text{ MW} ,$$

$$C_{2(\text{max.})} = 2 \times 10^4 \text{ MW} ,$$

and

$$P_{(\text{max.})} = 1250 \text{ MW} .$$

The corresponding machine variables are $(10^{-3}C_1)$, $(5 \times 10^{-3}C_2)$, and $(.08P)$ respectively.

Write the magnitude scaled nuclear kinetics equations with the time scale equal to real system time. Let $C_{1s} = 10^{-3}C_1$, $C_{2s} = 5 \times 10^{-3}C_2$, and $P_s = .08P$.

$$\frac{dP_s}{dt} = 2.777 \times 10^3 \rho P_s - 7.333P_s + (.08)(0.02446)(10^3)C_{1s} + \frac{(.08)(.2245)(10^3)}{5} C_{2s} ;$$

$$\frac{dP_s}{dt} = 2.777 \times 10^3 \rho P_s - 7.333P_s + 1.957C_{1s} + 3.592C_{2s} ;$$

$$\frac{dC_{1s}}{dt} = \frac{(2.8333)(10^{-3})}{.08} P_s - 0.30456C_{1s} + 0.2416 C_{1s} (t - \tau_1) ;$$

$$\frac{dC_{1s}}{dt} = 0.0354P_s - 0.30456C_{1s} + 0.2416C_{1s}(t - \tau_1) ;$$

$$\frac{dC_{2s}}{dt} = \frac{(4.5)(5 \times 10^{-3})}{.08} P_s - 0.5046C_{2s} + 0.07204C_{2s}(t - \tau_1) ;$$

$$\frac{dC_{2s}}{dt} = 0.2813P_s - 0.5046C_{2s} + 0.07204C_{2s}(t - \tau_1) .$$

Calculate ρ_o , the reactivity required to offset the effect of the delayed neutrons lost in the loop external to the core, for design point steady state operation.

$$\begin{aligned} \frac{dP}{dt} = 0 = 2.777 \times 10^3 \rho_o (1000) - 7.333(1000) + 0.02446(45,000) \\ + 0.2245(10,404) ; \end{aligned}$$

$$\rho_o = 0.001403 .$$

Temperature Coefficients of Reactivity

There are two reactor core zones with vastly different power densities. Zone 1 produces 79% of the total fission power while zone 2 produces 15% of the total fission power. The remaining 6% of the fission power is produced in the annulus, plenums, etc. These are very low power density regions that are not included in the simulation model; therefore, their contributions to the temperature coefficient of reactivity are relatively unimportant and they will be ignored in the simulation. The average temperature to be used in

determining the effective reactivity change due to core temperature changes shall be a weighted average of the average temperatures of the various regions. As an approximation, the weighting factor for a given region shall be proportional to the fraction of total fission power produced in that region.

The equation for the fuel salt weighted average temperature, $T_{f \text{ avg.}}$, is as follows:

$$T_{f \text{ avg.}} = \left(\frac{\bar{T}_{f1} + \bar{T}_{f2}}{2} \right) (.79) + (\bar{T}_{f3})(.15) ;$$

$$T_{f \text{ avg. s}} = (\bar{T}_{f1s} + \bar{T}_{f2s})(.395) + \bar{T}_{f3s}(.15) .$$

The fuel salt weighted average temperature at design point, steady state, $T_{f \text{ avg}}^{(0)}$, is calculated as follows:

$$\begin{aligned} T_{f \text{ avg.}}^{(0)} &= \left[\frac{\bar{T}_{f1s}^{(0)} + \bar{T}_{f2s}^{(0)}}{2} \right] (20)(.79) + [\bar{T}_{f3s}^{(0)}](20)(.15) ; \\ &= \left(\frac{55.49 + 62.11}{2} \right) (20)(.79) + (58.8)(20)(.15) ; \end{aligned}$$

$$T_{f \text{ avg.}}^{(0)} = 929 + 176.4 = 1105.4^\circ\text{F} .$$

The equation for calculating the reactivity change as a result of fuel salt temperature changes is as follows:

$$\rho_f = [T_{f \text{ avg.}} - T_{f \text{ avg.}}^{(0)}]\alpha_f ,$$

where α_f = the temperature coefficient of reactivity for the fuel salt, $(\partial K/K)/^\circ F$.

$$\rho_f = (T_{f \text{ avg.}} - 1105.4)(-1.789 \times 10^{-5}) ;$$

$$\rho_f = (T_{f \text{ avg. s}} - 55.27)(-1.789 \times 10^{-5})(20) ;$$

$$\rho_f = (T_{f \text{ avg. s}} - 55.27)(-3.578 \times 10^{-4}) .$$

For the graphite:

$$T_{g \text{ avg.}}(0) = \left(\frac{T_{g1} + T_{g2}}{2} \right) (.79) + T_{g3}(.15) ;$$

$$T_{g \text{ avg. s}}(0) = (T_{g1s} + T_{g2s})(.395) + 0.15T_{g3s} ;$$

$$T_{g \text{ avg. s}}(0) = (56.28 + 62.9)(.395) + 0.15(59.19) ;$$

$$T_{g \text{ avg.}}(0) = 47.08 + 8.88 = 55.96 .$$

$$\rho_g = [T_{g \text{ avg.}} - T_{g \text{ avg.}}(0)]\alpha_g ;$$

$$\rho_g = [T_{g \text{ avg. s}} - T_{g \text{ avg. s}}(0)]\alpha_g ;$$

$$\rho_g = (T_{g \text{ avg. s}} - 55.96)(1.305555 \times 10^{-5})(20) ;$$

$$\rho_g = (T_{g \text{ avg. s}} - 55.96)(2.611 \times 10^{-4}) .$$

The scaled equations are:

$$[10^4 \rho_f] = (T_{f \text{ avg. } s} - 55.27)(-3.578) ;$$

$$[10^4 \rho_g] = (T_{g \text{ avg. } s} - 55.96)(2.611) .$$

The chosen time scaling was such that 20 sec of computer time was equivalent to 1 sec of system time.

The resulting machine equations are the following:

$$\frac{dP_s}{d\tau} = \frac{2.777 \times 10^3}{20} \rho_o P_s + \frac{2.777 \times 10^3}{20} \rho P_s - \frac{7.333}{20} P_s + \frac{1.957}{20} C_{1s} + \frac{3.592}{20} C_{2s} ,$$

where $\tau = 20t$.

$$\frac{dP_s}{d\tau} = 138.85 \rho_o P_s + 138.85 \rho P_s - 0.3667 P_s + 0.0979 C_{1s} + 0.1796 C_{2s} .$$

Likewise:

$$\frac{dC_{1s}}{d\tau} = 0.00177 P_s - 0.0152 C_{1s} + 0.01208 C_{1s} (t - \tau_1) ;$$

$$\frac{dC_{2s}}{d\tau} = 0.014065 P_s - 0.02523 C_{2s} + 0.0036 C_{2s} (t - \tau_1) .$$

7.1.1.2 The Reactor Core Heat Transfer Model

7.1.1.2.1 Graphite Heat Transfer Equations

$$M_{g1} C_{pg} \frac{dT_{g1}}{dt} = h_{fg} A_{g1} (\bar{T}_{f1} - T_{g1}) + K_{g1} P ,$$

where P is in Btu/sec.

$$1 \text{ MW}(t) = 948.6667 \text{ Btu/sec} .$$

Since the plant efficiency is such that 2250 MW(t) results in 1000 MW(e),

$$1 \text{ MW}(e) = 2.25 \text{ MW}(t) = 2.25(948.6667) \text{ Btu/sec} = 2134.5 \text{ Btu/sec} .$$

In the above equation, if we express P in terms of MW(e), we have:

$$\frac{dT_{g1}}{dt} = \frac{h_{fg} A_{g1}}{M_{g1} C_{pg}} (\bar{T}_{f1} - T_{g1}) + \frac{2134.5}{M_{g1} C_{pg}} K_{g1} P ;$$

$$K_{g1} = 0.032933 ;$$

$$\frac{dT_{g1}}{dt} = \frac{(0.29583)(15,039)}{(106,106.5)(0.42)} (\bar{T}_{f1} - T_{g1}) + \frac{(2134.5)(0.032933)}{(106,106.5)(0.42)} P ;$$

$$\frac{dT_{g1}}{dt} = 0.09983(\bar{T}_{f1} - T_{g1}) + 0.001577P .$$

Let $P_s = 0.08P$ and $T_{is} = T_i/20$.

$$\frac{dT_{g1s}}{dt} = .09983(\bar{T}_{f1s} - T_{g1s}) + \frac{.001577}{(20)(.08)} P_s ;$$

$$\frac{dT_{g1s}}{dt} = 0.09983(\bar{T}_{f1s} - T_{g1s}) + 0.000986P_s .$$

Let computer time, τ , equal $20t$.

$$\frac{dT_{g1s}}{d\tau} = \frac{0.09983}{20} (\bar{T}_{f1s} - T_{g1s}) + \frac{0.000986}{20} P_s ;$$

$$\frac{dT_{g1s}}{d\tau} = 0.00499 (\bar{T}_{f1s} - T_{g1s}) + 0.0000493 P_s .$$

In a like manner:

$$\frac{dT_{g2s}}{d\tau} = 0.00499 (\bar{T}_{f2s} - T_{g2s}) + 0.0000493 P_s ;$$

$$\frac{dT_{g3s}}{d\tau} = 0.00861 (\bar{T}_{f3s} - T_{g3s}) + 0.00004155 P_s .$$

7.1.1.2.2 Fuel Salt Equations Describing the Generation and Transfer of Heat in the Reactor Core

Core Zone 1. --

$$M_{f1} C_{pf} \frac{d\bar{T}_{f1}}{dt} = F_1 C_{pf} (T_{fin} - \bar{T}_{f1}) + h_{fg} A_{f1} (T_{g1} - \bar{T}_{f1}) + K_{f1} P ,$$

where

P is expressed in Btu/sec (thermal),

$M_{f1} = 1/4$ fuel mass in core zone 1 = $58,074/4$ lb = 14,518.5 lb,

$F_1 =$ fuel salt mass flow rate in core zone 1 = $58,074$ lb/2.71 sec = 21,430 lb/sec,

$A_{f1} = 1/4$ of core zone 1 heat transfer area = $30,077/4$ ft² = 7519.25 ft²,

$K_{f1} = 0.1781$.

$$\frac{d\bar{T}_{f1}}{dt} = \frac{21430}{14518.5} (T_{fin} - \bar{T}_{f1}) + \frac{(0.29583)(7519.25)}{(14,518.5)(0.324)} (T_{g1} - \bar{T}_{f1}) + \frac{(.1781)(2134.5)}{(14,518.5)(0.324)} P ,$$

where P is expressed in MW(e).

The unscaled equation is:

$$\frac{d\bar{T}_{f1}}{dt} = 1.476(T_{fin} - \bar{T}_{f1}) + 0.4729(T_{g1} - \bar{T}_{f1}) + 0.080815P .$$

Allowing temperature maximums of 2000°F and a power maximum of 1250 MW(e), we have magnitude scaled variables of $T_i/20$ and $.08P$. Let $T_{i,s} = T_i/20$ and $P_s = .08P$.

$$\frac{d\bar{T}_{f1s}}{dt} = 1.476(T_{fins} - \bar{T}_{f1s}) + 0.4729(T_{g1s} - \bar{T}_{f1s}) + \frac{.080815}{(20)(.08)} P_s .$$

The magnitude scaled equation is:

$$\frac{d\bar{T}_{f1s}}{dt} = 1.476(T_{fins} - \bar{T}_{f1s}) + 0.4729(T_{g1s} - \bar{T}_{f1s}) + 0.0505P_s .$$

Let machine time = twenty times real system time;

$$\tau = 20t .$$

$$\frac{d\bar{T}_{f1s}}{d\tau} = \frac{1.476}{20} (T_{f1s} - \bar{T}_{f1s}) + \frac{0.4729}{20} (T_{g1s} - \bar{T}_{f1s}) + \frac{.0505}{20} P_s .$$

The time and magnitude scaled equation is:

$$\frac{d\bar{T}_{f1s}}{d\tau} = 0.0738(T_{f1s} - \bar{T}_{f1s}) + 0.0236(T_{g1s} - \bar{T}_{f1s}) + 0.002525P_s .$$

The equations for the other three fuel salt lumps in core zone 1 are developed in a like manner and the resulting equations are as follows:

$$\frac{dT_{f01s}}{dt} = 1.476(\bar{T}_{f1s} - T_{f01s}) + 0.4729(T_{g1s} - \bar{T}_{f1s}) + 0.0564P_s ;$$

$$\frac{dT_{f01s}}{d\tau} = 0.0738(\bar{T}_{f1s} - T_{f01s}) + 0.0236(T_{g1s} - \bar{T}_{f1s}) + 0.00282P_s ;$$

$$\frac{d\bar{T}_{f2s}}{dt} = 1.476(T_{f01s} - \bar{T}_{f2s}) + 0.4729(T_{g2s} - \bar{T}_{f2s}) + 0.0564P_s ;$$

$$\frac{d\bar{T}_{f2s}}{d\tau} = 0.0738(T_{f01s} - \bar{T}_{f2s}) + 0.0236(T_{g2s} - \bar{T}_{f2s}) + 0.00282P_s ;$$

$$\frac{dT_{f02s}}{dt} = 1.476(\bar{T}_{f2s} - T_{f02s}) + 0.4729(T_{g2s} - \bar{T}_{f2s}) + 0.04863P_s ;$$

$$\frac{dT_{f02s}}{d\tau} = 0.0738(\bar{T}_{f2s} - T_{f02s}) + 0.0236(T_{g2s} - \bar{T}_{f2s}) + 0.002432P_s .$$

Core Zone 2. --

$$M_{f3} C_{pf} \frac{d\bar{T}_{f3}}{dt} = F_3 C_{pf} (T_{fin} - \bar{T}_{f3}) + h_{fg} A_{f3} (T_{g3} - \bar{T}_{f3}) + K_{f3} P ,$$

where P is expressed in Btu/sec (thermal),

$$M_{f3} = 1/2 \text{ fuel mass in core zone 2} = 1/2 \times 61,428 \text{ lb} = 30,714 \text{ lb},$$

$$F_3 = \text{fuel salt mass flow rate in core zone 2} = 61,428 \text{ lb}/12.5 \text{ sec} = 4914.24 \text{ lb/sec},$$

$$A_{f3} = 1/2 \text{ heat transfer area in core zone 2} = 1/2 \times 14206 \text{ ft}^2 = 7103 \text{ ft}^2,$$

$$K_{f3} = 0.0863.$$

$$\frac{d\bar{T}_{f3}}{dt} = \frac{4914.24}{30,714} (T_{fin} - \bar{T}_{f3}) + \frac{(0.29583)(7103)}{(30,714)(.324)} (T_{g3} - \bar{T}_{f3}) + \frac{(0.0863)(2134.5)}{(30714)(.324)} P ;$$

$$\frac{d\bar{T}_{f3}}{dt} = 0.1600(T_{fin} - \bar{T}_{f3}) + 0.2112(T_{g3} - \bar{T}_{f3}) + 0.01851P .$$

For the reason previously stated, use the magnitude scaled variables:

$$T_{is} = T_i/20 \text{ and } P_s = .08P .$$

$$\frac{d\bar{T}_{f3s}}{dt} = 0.1600(T_{fins} - \bar{T}_{f3s}) + 0.2112(T_{g3s} - \bar{T}_{f3s}) + \frac{0.01851}{(20)(.08)} P_s ;$$

$$\frac{d\bar{T}_{f3s}}{dt} = 0.1600(T_{fins} - \bar{T}_{f3s}) + 0.2112(T_{g3s} - \bar{T}_{f3s}) + 0.01157P_s ;$$

$$\tau = 20t .$$

$$\frac{d\bar{T}_{f3s}}{d\tau} = \frac{0.1600}{20} (T_{fins} - \bar{T}_{f3s}) + \frac{0.2112}{20} (T_{g3s} - \bar{T}_{f3s}) + \frac{0.01157}{20} P_s ;$$

$$\frac{d\bar{T}_{f3s}}{d\tau} = 0.0080(T_{fins} - \bar{T}_{f3s}) + 0.01056(T_{g3s} - \bar{T}_{f3s}) + 0.000579P_s .$$

The equations for the second half of fuel lump number 3 were developed in a like manner. The resulting equations were as follows:

$$\frac{dT_{f03s}}{dt} = 0.1600(\bar{T}_{f3s} - T_{f03s}) + 0.2112(T_{g3s} - \bar{T}_{f3s}) + 0.01136P_s ;$$

$$\frac{dT_{f03s}}{d\tau} = 0.0080(\bar{T}_{f3s} - T_{f03s}) + 0.01056(T_{g3s} - \bar{T}_{f3s}) + 0.000568P_s .$$

The temperature of the salt at the reactor core outlet can be calculated by weighting the outlet temperatures of the salt in zones 1 and 2 proportional to their respective mass flow rates.

$$\begin{aligned} WF_1 &= \text{weighting factor in zone 1} \\ &= \frac{21,430 \text{ lb/sec}}{21,430 \text{ lb/sec} + 4914 \text{ lb/sec}} = \frac{21,430}{26,344} = 0.8135 . \end{aligned}$$

$$WF_2 = \frac{4914 \text{ lb/sec}}{26,344 \text{ lb/sec}} = 0.1865 .$$

Let $T_{ROs} = T_{RO}/20 =$ magnitude scaled temperature of the fuel salt at the reactor core outlet.

$$T_{RO} = 0.8135T_{f02} + 0.1865T_{f03} ;$$

$$T_{ROs} = 0.8135T_{f02s} + 0.1865T_{f03s} .$$

7.1.1.3 Piping Lag Equations

The primary salt residence time in the piping between the reactor core and the primary heat exchanger inlet is 2.125 sec. The piping lag will be approximated by a first order lag, indicating perfect mixing. The first order lag equation is as follows:

$$\frac{dT_{xin}}{dt} = \frac{1}{2.125} (T_{RO} - T_{xin}) .$$

The magnitude and time scaled equation is:

$$\frac{dT_{xins}}{d\tau} = 0.0235(T_{ROs} - T_{xins}) .$$

The residence time in the piping carrying the primary salt from the primary heat exchanger to the reactor was considered to be the same as that in the opposite direction; namely, 2.125 sec. The resulting first order lag equation is:

$$\frac{dT_{fins}}{d\tau} = 0.0235(T_{f10s} - T_{fins}) .$$

7.1.1.4 Primary Heat Exchanger Model

7.1.1.4.1 Primary Salt Equations

$$M_{f7} C_{pf} \frac{dT_{f7}}{dt} = F_x C_{pf} (T_{xin} - T_{f7}) + h_{fp} A_{fx} (T_{t1} - T_{f7}) ;$$

$$M_{f7} = M_{f8} = M_{f9} = M_{f10} = \frac{11870 \text{ lb}}{4} = 2967.5 \text{ lb} ;$$

$$F_x = \frac{11,070 \text{ lb}}{1.8 \text{ sec}} = 6594 \text{ lb/sec} ;$$

$$A_{fx} = \frac{11,050}{4} \text{ ft}^2 = 2762.5 \text{ ft}^2 .$$

The resistance to heat flow from the tubes into the primary salt was considered to be the film resistance plus 1/2 the tube wall resistance.

$$\text{Film resistance} = \frac{1}{3500} \text{ Btu/hr-ft}^2\text{-}^\circ\text{F} = 0.0002857 \frac{\text{hr-ft}^2\text{-}^\circ\text{F}}{\text{Btu}} .$$

$$\text{Tube wall resistance} = \frac{1}{3963} \text{ Btu/hr-ft}^2\text{-}^\circ\text{F} = 0.0002523 \frac{\text{hr-ft}^2\text{-}^\circ\text{F}}{\text{Btu}} .$$

$$1/2 \text{ wall resistance} = \frac{0.0002523}{2} = 0.0001262 .$$

$$\text{Total resistance, } R_{T1} = 0.0004119 .$$

$$h_{fp} = \frac{1}{R_{T1}} \times \frac{1}{3600} = 0.67438 \text{ btu/sec-ft}^2\text{-}^\circ\text{F} .$$

$$\frac{dT_{f7}}{dt} = \frac{6594}{2967.5} (T_{xin} - T_{f7}) + \frac{(0.67438)(2762.5)}{(2967.5)(.324)} (T_{t1} - T_{f7}) .$$

Use scaled variables $T_i/20$.

$$\text{Let } T_{is} = T_i/20 .$$

$$\frac{dT_{f7s}}{dt} = 2.222(T_{xins} - T_{f7s}) + 1.938(T_{t1s} - T_{f7s}) .$$

The machine timed equation is:

$$\frac{dT_{f7s}}{d\tau} = \frac{2.222}{20} (T_{xins} - T_{f7s}) + \frac{1.938}{20} (T_{t1s} - T_{f7s}) ;$$

$$\frac{dT_{f7s}}{d\tau} = 0.111(T_{xins} - T_{f7s}) + .0969(T_{t1s} - T_{f7s}) .$$

The following equations are developed using the same approach:

$$\frac{dT_{f8}}{dt} = 2.222(T_{f7} - T_{f8}) + 1.938(T_{t1} - T_{f7}) ;$$

$$\frac{dT_{f8s}}{dt} = 2.222(T_{f7s} - T_{f8s}) + 1.938(T_{t1s} - T_{f7s}) ;$$

$$\frac{dT_{f8s}}{d\tau} = 0.1111(T_{f7s} - T_{f8s}) + 0.0969(T_{t1s} - T_{f7s}) ;$$

$$\frac{dT_{f9}}{dt} = 2.222(T_{f8} - T_{f9}) + 1.938(T_{t2} - T_{f9}) ;$$

$$\frac{dT_{f9s}}{dt} = 2.222(T_{f8s} - T_{f9s}) + 1.938(T_{t2s} - T_{f9s}) ;$$

$$\frac{dT_{f9s}}{d\tau} = 0.1111(T_{f8s} - T_{f9s}) + 0.0969(T_{t2s} - T_{f9s}) ;$$

$$\frac{dT_{f10}}{dt} = 2.222(T_{f9} - T_{f10}) + 1.938(T_{t2} - T_{f9}) ;$$

$$\frac{dT_{f10s}}{dt} = 2.222(T_{f9s} - T_{f10s}) + 1.938(T_{t2s} - T_{f9s}) ;$$

$$\frac{dT_{f10s}}{d\tau} = 0.1111(T_{f9s} - T_{f10s}) + 0.0969(T_{t2s} - T_{f9s}) .$$

7.1.1.4.2 Tube Wall Heat Transfer

$$M_T C_T \frac{dT_{t1}}{dt} = h_{fp} A_T (T_{f7} - T_{t1}) - h_{Tc} A_T (T_{t1} - T_{c3}) ;$$

$$M_T = \frac{16,020 \text{ lb}}{2} = 8,010 \text{ lb} .$$

$$C_T = 0.129 \text{ Btu/lb-}^\circ\text{F.}$$

$$h_{fp} = 0.67438 \text{ (previous calculation).}$$

$$A_T = \frac{11,050 \text{ ft}^2}{2} = 5525 \text{ ft}^2.$$

The resistance to heat flow from the tube walls to the secondary salt is comprised of the film resistance and one half the tube wall resistance.

Since the secondary salt flow rate is variable, h_{Tc} will be variable also. In this model, h_{Tc} is proportional to the secondary salt mass flow rate raised to the .6 power.

For design point, steady state conditions,

$$\begin{aligned} h_{Tc} = h_{Tc,0} &= \frac{1}{\frac{1}{2130} + \frac{1}{3963 \times 2}} = \frac{1}{.0004695 + .0001262} = \frac{1}{.0005957} \\ &= 1678.7 \text{ Btu/hr-ft}^2\text{-}^\circ\text{F} \\ &= 0.4663 \text{ Btu/sec-ft}^2\text{-}^\circ\text{F} . \end{aligned}$$

The variable used in the equations shall be $\left[0.8 \frac{h_{Tc}}{h_{Tc,0}} \right]$.

$$\frac{dT_{t1}}{dt} = \frac{(.67438)(5525)}{(8010)(.129)} (T_{f7} - T_{t1}) - \frac{(.4663)(5525)}{(8010)(.129)(.8)} \left[.8 \frac{h_{Tc}}{h_{Tc,0}} \right] (T_{t1} - T_{c3}) ;$$

$$\frac{dT_{t1}}{dt} = 3.606(T_{f7} - T_{t1}) - 3.1166 \left[.8 \frac{h_{Tc}}{h_{Tc,0}} \right] (T_{t1} - T_{c3}) ;$$

$$\frac{dT_{t1s}}{dt} = 3.606(T_{f7s} - T_{t1s}) - 3.1166 \left[.8 \frac{h_{Tc}}{h_{Tc,0}} \right] (T_{t1s} - T_{c3s}) ;$$

$$\frac{dT_{t1s}}{d\tau} = 0.1803(T_{f7s} - T_{t1s}) - 0.1558 \left[.8 \frac{h_{Tc}}{h_{Tc,0}} \right] (T_{t1s} - T_{c3s}) .$$

Similarly:

$$\frac{dT_{t2}}{dt} = 3.606(T_{f9} - T_{t2}) - 3.1166 \left[.8 \frac{h_{Tc}}{h_{Tc,0}} \right] (T_{t2} - T_{c1}) ;$$

$$\frac{dT_{t2s}}{dt} = 3.606(T_{f9s} - T_{t2s}) - 3.1166 \left[.8 \frac{h_{Tc}}{h_{Tc,0}} \right] (T_{t2s} - T_{c1s}) ;$$

$$\frac{dT_{t2s}}{d\tau} = 0.1803(T_{f9s} - T_{t2s}) - 0.1558 \left[.8 \frac{h_{Tc}}{h_{Tc,0}} \right] (T_{t2s} - T_{c1s}) .$$

7.1.1.4.3 Secondary Salt Equations

$$M_{c1} C_{pc} \frac{dT_{c1}}{dt} = F_c C_{pc} (T_{cin} - T_{c1}) + h_{Tc} A_c (T_{t2} - T_{c1}) ;$$

$$M_{c1} = \frac{34,428 \text{ lb}}{4} = 8607 \text{ lb} .$$

Since the secondary salt flow rate is a variable, F_c and h_{Tc} will be variables.

For steady state, design point conditions,

$$F_c = F_{c,0} = 1.78 \times 10^7 \text{ lb/hr} = 4944 \text{ lb/sec} ,$$

and

$$h_{Tc} = h_{Tc,0} = 0.4663 \text{ Btu/sec-ft}^2\text{-}^\circ\text{F} .$$

$$A_c = \frac{11050 \text{ ft}^2}{4} = 2762.5 \text{ ft}^2 .$$

The variables $\left[.8 \frac{F_c}{F_{c,0}} \right]$ and $\left[.8 \frac{h_{Tc}}{h_{Tc,0}} \right]$ shall be used in the model.

$$\frac{dT_{c1}}{dt} = \frac{F_{c,0} C_{pc}}{M_{c1} C_{pc} (.8)} \left[.8 \frac{F_c}{F_{c,0}} \right] (T_{cin} - T_{c1}) + \frac{h_{Tc,0} A_c}{M_{c1} C_{pc} (.8)} \left[.8 \frac{h_{Tc}}{h_{Tc,0}} \right] (T_{t2} - T_{c1}) ;$$

$$\frac{dT_{c1}}{dt} = \frac{(4944)}{(8607)(.8)} \left[.8 \frac{F_c}{F_{c,0}} \right] (T_{cin} - T_{c1}) + \frac{(.4663)(2762.5)}{(8607)(.360)(.8)} \left[.8 \frac{h_{Tc}}{h_{Tc,0}} \right] (T_{t2} - T_{c1}) ;$$

$$\frac{dT_{c1}}{dt} = 0.7180 \left[.8 \frac{F_c}{F_{c,0}} \right] (T_{cin} - T_{c1}) + 0.5197 \left[.8 \frac{h_{Tc}}{h_{Tc,0}} \right] (T_{t2} - T_{c1}) ;$$

$$\frac{dT_{c1s}}{dt} = 0.7180 \left[.8 \frac{F_c}{F_{c,0}} \right] (T_{cins} - T_{c1s}) + 0.5197 \left[.8 \frac{h_{Tc}}{h_{Tc,0}} \right] (T_{t2s} - T_{c1s}) ;$$

$$\frac{dT_{c1s}}{dt} = 0.0359 \left[.8 \frac{F_c}{F_{c,0}} \right] (T_{c1s} - T_{c1s}) + 0.0253 \left[.8 \frac{h_{Tc}}{h_{Tc,0}} \right] (T_{t2s} - T_{c1s}) .$$

Similarly:

$$\frac{dT_{c2}}{dt} = 0.7180 \left[.8 \frac{F_c}{F_{c,0}} \right] (T_{c1} - T_{c2}) + 0.5197 \left[.8 \frac{h_{Tc}}{h_{Tc,0}} \right] (T_{t2} - T_{c1}) ;$$

$$\frac{dT_{c2s}}{dt} = 0.7180 \left[.8 \frac{F_c}{F_{c,0}} \right] (T_{c1s} - T_{c2s}) + 0.5197 \left[.8 \frac{h_{Tc}}{h_{Tc,0}} \right] (T_{t2s} - T_{c1s}) ;$$

$$\frac{dT_{c2s}}{dt} = 0.0359 \left[.8 \frac{F_c}{F_{c,0}} \right] (T_{c1s} - T_{c2s}) + 0.0253 \left[.8 \frac{h_{Tc}}{h_{Tc,0}} \right] (T_{t2s} - T_{c1s}) ;$$

$$\frac{dT_{c3}}{dt} = 0.7180 \left[.8 \frac{F_c}{F_{c,0}} \right] (T_{c2} - T_{c3}) + 0.5197 \left[.8 \frac{h_{Tc}}{h_{Tc,0}} \right] (T_{t1} - T_{c3}) ;$$

$$\frac{dT_{c3s}}{dt} = 0.7180 \left[.8 \frac{F_c}{F_{c,0}} \right] (T_{c2s} - T_{c3s}) + 0.5197 \left[.8 \frac{h_{Tc}}{h_{Tc,0}} \right] (T_{t1s} - T_{c3s}) ;$$

$$\frac{dT_{c3s}}{dt} = 0.0359 \left[.8 \frac{F_c}{F_{c,0}} \right] (T_{c2s} - T_{c3s}) + 0.0253 \left[.8 \frac{h_{Tc}}{h_{Tc,0}} \right] (T_{t1s} - T_{c3s}) ;$$

$$\frac{dT_{c4}}{dt} = 0.7180 \left[.8 \frac{F_c}{F_{c,0}} \right] (T_{c3} - T_{c4}) + 0.5197 \left[.8 \frac{h_{Tc}}{h_{Tc,0}} \right] (T_{t1} - T_{c3}) ;$$

$$\frac{dT_{c4s}}{dt} = 0.7180 \left[.8 \frac{F_c}{F_{c,0}} \right] (T_{c3s} - T_{c4s}) + 0.5197 \left[.8 \frac{h_{Tc}}{h_{Tc,0}} \right] (T_{t1s} - T_{c3s}) ;$$

$$\frac{dT_{c4s}}{d\tau} = 0.0359 \left[.8 \frac{F_c}{F_{c,0}} \right] (T_{c3s} - T_{c4s}) + 0.0253 \left[.8 \frac{h_{Tc}}{h_{Tc,0}} \right] (T_{t1s} - T_{c3s}) .$$

7.2 B: Fortran Source Program for MSBR Steam Generator Simulation*

7.2.1 Program

```

C      MSBR STEAM GENERATOR SIMULATION
      DIMENSION THETA(100),V(100),T(100),P(100),WMU(100),CW(100),PR(100)
0      I,H(100),D(100),RE(100),DK(100),THETAK(100),VK(100),C(100),HK(100)
      DIMENSION IX(100)
      DIMENSION PL(100),HL(100),VL(100),THETAL(100)
      COMMON IR,IW
      IR=2
      IW=5
      READ (IR,3000) N
3000  FORMAT(I5)
      CALL MSBR(N,THETA,V,T,P,WMU,CW,PR,H,D,RE,DK,THETAK,VK,C,HK,IX,PL,H
      IL,VL,THETAL)

      CALL EXIT
      END
      SUBROUTINE MSBR(N,THETA,V,T,P,WMU,CW,PR,H,D,RE,DK,THETAK,VK,C,HK,I
0      IX,PL,HL,VL,THETAL)

      COMMON IR,IW
      DIMENSION IAR(2),IDV(7),IDV1(4)
      DIMENSION THETA(N),V(N),T(N),P(N),WMU(N),CW(N),PR(N),H(N),D(N),RE(
      IN),DK(N),THETAK(N),VK(N),C(N),HK(N)
      DIMENSION IX(N)
      DIMENSION PL(N),HL(N),VL(N),THETAL(N)
      DIMENSION TABH(30,6),TABD(120,6),TABT(120,6)
      DIMENSION TABMU(18,2),TABK(18,2),TABPR(18,2)
      DIMENSION ILB(3),IDH(3),IVTHET(2),IDH1(2)
      DIMENSION IOUTA(4),IOUTV(4)
      CALL INITA(IE,0)
      CALL INMUX(IE,0)
      CALL RUN(IE)
      READ(IR,300) IT
C      M IS THE NO. OF ITERATIONS PER TIME STEP.
      READ(IR,300) M
300  FORMAT(I5)
      CALL TSCAL(IE,IT)
      READ(IR,105) DX,DT,PK,PKF
105  FORMAT(2F6.2,2F10.5)
      READ(IR,106) HSF,SPH
106  FORMAT(2F6.2)
      READ(IR,107) IMDAC,IADH
107  FORMAT(2I6)
      READ (IR,103) HK1,HK2,HK3,C0N1,RK1,THETLB,VLB
103  FORMAT(7F10.2)
      READ(IR,110) CFC0N,SFV,RK2,SFVS
110  FORMAT(3F10.2,F10.7)
      READ (IR,120) IADV
120  FORMAT(I6)
      READ (IR,122) IRDAC,IMDAC1
122  FORMAT(2I8)
C      READ IN TABLE VALUES.

```

*See Sect. 7.2.2 for definition of variables.

```

      READ(IR,101) TABD
      READ(IR,101) TABT
101  FØRMAT(10F8.2)
      READ(IR,100) TABH
100  FØRMAT(10F8.2)
      READ(IR,104) TABMU
      READ(IR,104) TABK
      READ(IR,104) TABPR
104  FØRMAT(10F8.2)
C    READ IN TABLE LIMITS.
      READ (IR,102) TMINH,TMAXH,DELTH,NTH,PMINH,PMAXH,DELPH,NPH
      READ (IR,102) HMIND,HMAXD,DELHD,NHD,PMIND,PMAXD,DELPH,NPD
      READ (IR,102) TMINM,TMAXM,DELTM,NTM,PMINM,PMAXM,DELPM,NPM
      READ (IR,102) TMINK,TMAXK,DELTK,NTK,PMINK,PMAXK,DELPK,NPK
      READ (IR,102) HMINT,HMAXT,DELTT,NTT,PMINT,PMAXT,DELPT,NPT
102  FØRMAT(3F8.2,16,3F8.2,15)
C    READ INITIAL GUESSES FØR VALUES ØF VARIABLES.
      READ(IR,108) H
108  FØRMAT(10F8.1)
      READ(IR,108) P
      READ(IR,108) THETA
      READ(IR,108) V
C    SET UP ADDRESSES FØR ØUTPUTTING VALUES ØF VARIABLES
C    FØM THE ANALØG CØMPUTER.
      READ(IR,109) IØUTA
109  FØRMAT(4I6)
C    INITIALIZE CØEFF. DEVICE SETTING RØUTINES.
      CALL ADDR(IADH,IADHD)
      CALL ADDR(IADV,IADVD)
      CALL PREB1(IADHD,IDH,3)
      CALL PREB2(IADHD,IDH,2)
      CALL PREB3(IADVD,IDV,7)
      CALL PREB4(IADVD,IDV,4)
C    PUT ANALØG CØMPUTER LEFT TØ RIGHT INTEGRATØRS IN IC MØDE.
      CALL SETWD(0,0)
      ALF=.5
C    KT IS THE TIME STEP CØUNT VARIABLE.
      KT=0
C    START TIME STEP TIMER AT NEXT P SIGNAL PIP.
2003 CALL SETWD(0,48)
      KT=KT+1
C    READ VALUES ØF PLB,TLB,AND VS FØM ANALØG AMPLIFIERS.
      CALL ADDR(6220,IAB1)
      CALL SCANH(IAB1,ILB,3)
C    HAS TIME STEP TIMER CØUNTER STARTED CØUNTING?
3005 IF(ITEST(IE,0,13)) 3005,3005,3006
3006 PLB=ILB(1)
      TLB=ILB(2)*1.E-1
      VS=ILB(3)*1.E-4
C    READ THE THRØTTLE SETTING AND THE SALT TEMP. AT THE RIGHT BØUNDARY
      CALL ADDR(6262,IAB3)
      CALL SCANH(IAB3,IAR,2)
C    CHECK TLB AND PLB AGAINST THE RANGE ØF TABH.
      IF(PLB.GE.PMINH.AND.PLB.LE.PMAXH.AND.TLB.GE.TMINH.AND.TLB.LE.TMAXH
1) GØ TØ 11
      WRITE(IW,10)
10  FØRMAT(1X,'EITHER PLB ØR TLB, ØR BØTH, IS ØUT ØF RANGE ØF TABH.')
```

STØP THE PRØGRAM
GØ TØ 99

```

C    GET VALUE ØF H AT LEFT BØUNDARY, HLB, FØM H(P,T), TABH.
11  CALL TERP2(TABH,TLB,PLB,HLB,TMINH,TMAXH,DELTH,NTH,PMINH,PMAXH,DELP
```

```

IH,NPH)
  HLBS=(HLB-1100)*25.
  XY=HLBS-.5
  IDH(3)=IFIX(XY)
  H0=HK2*VS**0.60
C   GET DENSITY AT LEFT BOUNDARY, DLB, FROM D(P,H) TABLE, TABD.
  IF(PLB.GE.PMIND.AND.PLB.LE.PMAXD.AND.HLB.GE.HMIND.AND.HLB.LE.HMAXD)
0   1) GO TO 21
  WRITE(IW,20)
20  FORMAT(IX,'EITHER PLB OR HLB, OR BOTH, IS OUT OF RANGE OF TABD.')

  GO TO 99
21  CALL TERP2(TABD,HLB,PLB,DLB,HMIND,HMAXD,DELHD,NHD,PMIND,PMAXD,DELP
0   1D,NPD)
C   CHECK RANGE OF VISCOSITY TABLE, TABMU, AND GET VISCOSITY VALUE AT
C   LEFT BOUNDARY, WMULB.
  IF(PLB.GE.PMINM.AND.PLB.LE.PMAXM.AND.TLB.GE.TMINM.AND.TLB.LE.TMAXM)
0   1) GO TO 31
  WRITE(IW,30)
30  FORMAT(IX,'EITHER PLB OR TLB, OR BOTH, IS OUT OF RANGE OF TABMU.')
0   GO TO 99
31  CALL TERP2(TABMU,TLB,PLB,WMULB,TMINM,TMAXM,DELTM,NTM,PMINM,PMAXM,D
  1ELPM,NPM)
  IF(PLB.GE.PMINK.AND.PLB.LE.PMAXK.AND.TLB.GE.TMINK.AND.TLB.LE.TMAXK)
0   1) GO TO 51
  WRITE(IW,40)
40  FORMAT(IX,'EITHER PLB OR TLB, OR BOTH, IS OUT OF RANGE OF TABK.')
0   GO TO 99
51  CALL TERP3(TABK,TABPR,TLB,PLB,CWLB,PRLB,TMINK,TMAXK,DELTK,NTK,PMIN
  1K,PMAXK,DELPK,NPK)
C   SAVE VALUES OF P,H,V, AND THETA FOR NEXT TIME STEP CALCULATION.
  DO 331 IK=1,N
  PL(IK)=P(IK)
331  HL(IK)=H(IK)
  DO 401 LL=1,N
  VL(LL)=V(LL)
401  THETAL(LL)=THETA(LL)
C   KI IS ITERATION COUNT VARIABLE.
  KI=0
C   START ITERATION
1000 KI=KI+1
  IF(KT-1) 66,66,67
  66  IF(KI-1) 67,65,67
  65  VLB=20.25
C   CALCULATE THE REYNOLDS NO. AT THE LEFT BOUNDARY,RELB.
  67  RELB=C0N1*DLB*VLB/WMULB
C   CALCULATE THE INSIDE FILM HEAT TRANSFER COEFFICIENT AT THE LEFT B0
UNDARY,
C   HILB
  HILB=HK1*CWLB*RELB**0.923*PRLB**0.613
C   CALCULATE THE OVERALL HEAT TRANSFER COEFFICIENT AT THE LEFT BOUNDAR
Y,HTCLB.
  HTCLB=HILB*H0*HK3/(HILB*H0+HILB*HK3+H0*HK3)
C   CALCULATE THE COMPONENTS OF THE DERIVATIVE OF ENTHALPY AT THE LEF
T BOUNDA
C   RY, DH1LB AND DH2LB.
  IF(KT-1) 77,75,77
75  PHLB=HLB

```

```

77 DH1LB=25.*(RK1*HTCLB/DLB*(THETLB-TLB)+(PHLB-1100.)/DT)/VLB
   IF(KI-M) 150,151,151
151 PHLB=HLB
150 DH1LBS=DH1LB
   XY=DH1LBS+.5
   IDH(1)=IFIX(XY)
   DH2LB=-1.0/(VLB*DT)
   DH2LBS=DH2LB*1.E4
   XY=DH2LBS-.5
   IDH(2)=IFIX(XY)
C   SET H DERIVATIVE DACS WITH AN UPDATE CODE OF ZERO.
   CALL DACU(IE,IMDAC,0)
   CALL DACU(IE,IADH,0)
   CALL SETBBI
C   PUT THE LEFT TO RIGHT INTEGRATORS IN THE OP MODE AND START
C   THE BCD COUNTER.
   CALL SETWD(0,34)
   DO 15 I=1,N
C   CALCULATE P FOR PRESENT SPACE INCREMENT AND H DERIVATIVE FOR NEXT
   SPACE
C   INCREMENT WHILE ANALOG IS INTEGRATING OVER THE PRESENT SPACE INCRE
   MENT.
   IF(P(I).GE.PMIND.AND.P(I).LE.PMAXD.AND.H(I).GE.HMIND.AND.H(I).LE.H
   IMAXD) GO TO 61
   WRITE(IW,60) I,KT,KI
60 FORMAT(1X,'EITHER P(I) OR H(I), OR BOTH, IS OUT OF RANGE OF TABD F
   10R I=',I4,'KT=',I10,'KI=',I4)
   WRITE(IW,8000) P(I),H(I)
8000 FORMAT(1X,'P(I)=' ,F8.2, ' H(I)=' ,F8.2)
   GO TO 99
61 CALL TERP3(TABD,TABT,H(I),P(I),D(I),T(I),HMIND,HMAXD,DELHD,NHD,PMI
   IND,PMAXD,DELPD,NPD)
   IF(P(I).GE.PMINM.AND.P(I).LE.PMAXM.AND.T(I).GE.TMINM.AND.T(I).LE.T
   IMAXM) GO TO 71
   WRITE(IW,70) I,KT,KI
70 FORMAT(1X,'EITHER P(I) OR T(I), OR BOTH, IS OUT OF RANGE OF TABMU
   1FOR I=',I4,'KT=',I10,'KI=',I4)
   GO TO 99
71 CALL TERP2(TABMU,T(I),P(I),WMU(I),TMINM,TMAXM,DELTM,NTM,PMINM,PMAX
   M,DELPM,NPM)
   RE(I)=CON1*D(I)*V(I)/WMU(I)
   IF(P(I).GE.PMINK.AND.P(I).LE.PMAXK.AND.T(I).GE.TMINK.AND.T(I).LE.T
   IMAXK) GO TO 91
   WRITE(IW,80) I,KT,KI
80 FORMAT(1X,'EITHER P(I) OR T(I), OR BOTH, IS OUT OF RANGE OF TABK F
   10R I=',I4,'KT=',I10,'KI=',I4)
   GO TO 99
91 CALL TERP3(TABK,TABPR,T(I),P(I),CW(I),PR(I),TMINK,TMAXK,DELTK,NTK,
   IPMINK,PMAXK,DELPK,NPK)
   HI=HK1*CW(I)*RE(I)**.923*PR(I)**.613
   HTC=HI*H0*HK3/(HI*H0+HI*HK3+H0*HK3)
   IF(KT-1) 93,92,93
92 HK(I)=H(I)
93 CONTINUE
   DH1=25.*(RK1*HTC/D(I)*(THETA(I)-T(I))+(DK(I)-1100.)/DT)/V(I)
   DH1S=DH1
   XY=DH1S+.5
   IDH1(1)=IFIX(XY)

```

```

DH2=-1.0/(V(I)*DT)
DH2S=DH2*1.E4
XY=DH2S-.5
IDH1(2)=FIX(XY)
C   CALCULATE P(I)
   IF(I-1) 53,52,53
52  IF(KT-1) 72,54,72
54  VKLB=VLB
   72 P(I)=-DLB*VLB*DX/PK*((V(I)-VLB)/DX+(VLB-VKLB)/DT+PKF*VLB)+PLB
   GO TO 12
   53 IF(KT-1) 73,78,73
78  VK(I-1)=V(I-1)
73  P(I)=-D(I-1)*V(I-1)*DX/PK*((V(I)-V(I-1))/DX+(V(I-1)-VK(I-1))/DT+PK
0   IF*V(I-1))+P(I-1)
C   CHECK ANALØG COMPUTER FØR HØLD MØDE.
12  IF(ITEST(IE,0,15)) 12,12,13
13  CONTINUE
C   RESET CLEAR BIT ,BIT15.
   CALL SETWD(0,34)
C   READ ENTHALPY AT I'TH X STATION.
   CALL ADDR(6223,IAB2)
   CALL SCANH(IAB2,IH,1)
   H(I)=1100.+IH*4.E-2
1201 IF(KL-M) 33,32,32
32  HK(I)=H(I)
33  CONTINUE
C   SET COEFFICIENT DEVICES FØR NEXT SPACE INCREMENT.
   CALL SETBB2
C   PUT THE LEFT TO RIGHT INTEGRATORS IN THE ØP MØDE.
   CALL SETWD(0,35)
15  CONTINUE
C   GO TO ANALØG IC MØDE ØN THE LEFT TO RIGHT INTEGRATORS.
   CALL SETWD(0,32)
C   GET WEIGHTED VALUES FØR H AND P.
   DØ 333 IK=1,N
   STØR=P(IK)
   P(IK)=ALF*P(IK)+(1.-ALF)*PL(IK)
   PL(IK)=STØR
   STØR=H(IK)
   H(IK)=ALF*H(IK)+(1.-ALF)*HL(IK)
333  HL(IK)=STØR
C   DØ RIGHT TO LEFT INTEGRATION USING CALCULATED VALUES ØF H AND P.
C   GET VALUE ØF DENSITY AT RIGHT HAND END ØF STEAM GENERATOR.
   IF(P(N).GE.PMIND.AND.P(N).LE.PMAXD.AND.H(N).GE.HMIND.AND.H(N).LE.H
1MAXD) GO TO 201
   WRITE(IW,200) N,N
200  FORMAT(1X,'EITHER P(',I2,') ØR H(',I2,'), ØR BØTH, ARE ØUT ØF RANG
   IE ØF TABD.')
   GO TO 99
201  CALL TERP3(TABD,TABT,H(N),P(N),D(N),T(N),HMIND,HMAXD,DELHD,NHD,PMI
0   IND,PMAXD,DELPD,NPD)
C   CALCULATE THE STEAM VELOCITY AT THE THROTTLE.
   AT=IAR(1)*1.E-4
   VT=CFCØN*P(N)/D(N)*AT
   SVT=VT*1.E2*SFV
   XY=SVT+.5
   IDV(5)=FIX(XY)
   V(N)=VT
C   CALCULATE THE DERIVATIVES ØF WATER VELOCITY AND SALT TEMP. AT
C   RIGHT BØUNDARY.
   IF(P(N-1).GE.PMIND.AND.P(N-1).LE.PMAXD.AND.H(N-1).GE.HMIND.AND.H(N

```

```

1-1).LE.HMAXD) G0 T0 211
WRITE(IW,210)
210 F0RMA'T(1X,'EITHER P(N-1) 0R H(N-1),0R B0TH, IS 0UT 0F RANGE 0F TA
0 1BD.')
G0 T0 99
211 CALL TERP2(TABD,H(N-1),P(N-1),D(N-1),HMIND,HMAXD,DELHD,NHD,PMIND,P
IMAXD,DELPD,NPD)
DV2RB=(D(N-1)-D(N))/(D(N)*DX)*1.E4
IF(DV2RB) 2527,2526,2526
2526 XY=DV2RB+.5
G0 T0 2528
2527 XY=DV2RB-.5
2528 IDV(2)=IFIX(XY)
IF(KT-1) 202,202,203
202 DK(N)=D(N)
203 DV1RB=SFV*(D(N)-DK(N))/(D(N)*DT)*1.E4
IF(DV1RB) 2529,2530,2530
2530 XY=DV1RB+.5
G0 T0 2531
2529 XY=DV1RB-.5
2531 IDV(1)=IFIX(XY)
IF(KI-M) 205,204,204
204 DK(N)=D(N)
205 C0NTINUE
IDV(7)=(IAR(2)*1.E-1-1050.)*.5E2
THETA(N)=IAR(2)*1.E-1
IF(T(N).GE.TMINM.AND.T(N).LE.TMAXM.AND.P(N).GE.PMINM.AND.P(N).LE.P
0 1MAXM) G0 T0 221
WRITE(IW,220)
220 F0RMA'T(1X,'EITHER T(N) 0R P(N), 0R B0TH, IS 0UT 0F RANGE 0F TABMU.
1')
G0 T0 99
221 CALL TERP2(TABMU,T(N),P(N),WMURB,TMINM,TMAXM,DELTM,NTM,PMINM,PMAXM
0 1,DELPN,NPM)
IF(P(N).GE.PMINM.AND.P(N).LE.PMAXM.AND.T(N).GE.TMINM.AND.T(N).LE.T
0 1MAXK) G0 T0 231
WRITE(IW,230)
230 F0RMA'T(1X,'EITHER P(N) 0R T(N), 0R B0TH, IS 0UT 0F RANGE 0F TABK')
0 G0 T0 99
231 CALL TERP3(TABK,TABPR,T(N),P(N),CWRB,PRRB,TMINM,TMAXM,DELTK,NTK,PM
0 1INK,PMAXK,DELPK,NPK)
RERB=C0N1*D(N)*VT/WMURB
HIRB=HK1*CWRB*RERB**.923*PRRB**.613
HTCRB=HIRB*H0*HK3/(HIRB*H0+HIRB*HK3+H0*HK3)
Z=(HTCRB*RK2+1/DT)/VS
IF(KT-1) 232,232,233
232 THETK1=IAR(2)*1.E-1
233 DT1RB=(HTCRB*RK2*T(N)+THETK1/DT)*50./VS-Z*.525E5
IF(KI-M) 235,234,234
234 THETK1=IAR(2)*1.E-1
235 DT1RBS=DT1RB*SFVS
IF(DT1RBS) 2532,2533,2533
2533 XY=DT1RBS+.5
G0 T0 2534
2532 XY=DT1RBS-.5
2534 DT2RB=Z*1.E4
DT2RBS=DT2RB*SFVS
YZ=DT2RBS+.5

```



```

IDV(3)=IFIX(XY)
IDV(4)=IFIX(YZ)
IDV(6)=1000
CALL DACU(IE,IRDAC,0)
CALL DACU(IE,IMDAC1,0)
C   SET IC AND DERIVATIVE DACS FOR SALT TEMP. AND WATER VELOCITY.
CALL SETBB3
C   PUT THE RIGHT TO LEFT INTEGRATORS IN THE OP MODE AND START BCD COUNTER.
CALL SETWD(0,40)
C   CALCULATE DERIVATIVES OF THETA AND V FOR NEXT X INCREMENT.
D0 115 J=1,N-1
L=N-J
IF(L-1) 303,303,302
302 IF(P(L-1).GE.PMIND.AND.P(L-1).LE.PMAXD.AND.H(L-1).GE.HMIND.AND.H(L
0   1-1).LE.HMAXD) G0 T0 241
WRITE(IW,240) L,KT,KI
240 FORMAT(1X,'EITHER P(L) OR H(L), OR BOTH, IS OUT OF RANGE OF TABD F
0   10R L=',I4,',KT=',I10,',KI=',I4)
WRITE(IW,9000) P(L),H(L)
9000 FORMAT(1X,'P(L)=',F8.2,' H(L)=',F8.2)
WRITE(IW,9050) (P(L),H(L),L=1,N)
9050 FORMAT(2F12.2)
G0 T0 99
241 CALL TERP3(TABD,TABT,H(L-1),P(L-1),D(L-1),T(L-1),HMIND,HMAXD,DELHD
0   1,NHD,PMIND,PMAXD,DELPD,NPD)
DV2=(D(L-1)-D(L+1))/(D(L)*2*DX)*1.E4
G0 T0 304
303 DV2=(DLB-D(L+1))/(D(L)*2*DX)*1.E4
304 IDV1(2)=IFIX(DV2)
IF(KT-1) 236,236,237
236 DK(L)=D(L)
237 DV1=SFV*(D(L)-DK(L))/(D(L)*DT)*1.E2
IF(DV1) 2535,2536,2536
2536 XY=DV1+.5
G0 T0 2537
2535 XY=DV1-.5
2537 IDV1(1)=IFIX(XY)
IF(KI-M) 239,238,238
238 DK(L)=D(L)
239 CONTINUE
IF(T(L).GE.TMINM.AND.T(L).LE.TMAXM.AND.P(L).GE.PMINM.AND.P(L).LE.P
0   1MAXM) G0 T0 251
WRITE(IW,250) L,KT,KI
250 FORMAT(1X,'EITHER P(I) OR T(I), OR BOTH, IS OUT OF RANGE OF TABMU
1FOR I=',I4,',KT=',I10,',KI=',I4)
G0 T0 99
251 CALL TERP2(TABMU,T(L),P(L),WMU(L),TMINM,TMAXM,DELTM,NTM,PMINM,PMAX
1M,DELPM,NPM)
IF(P(L).GE.PMINK.AND.P(L).LE.PMAXK.AND.T(L).GE.TMINK.AND.T(L).LE.T
0   1MAXK) G0 T0 261
WRITE(IW,260) L,KT,KI
260 FORMAT(1X,'EITHER P(I) OR T(I), OR BOTH, IS OUT OF RANGE OF TABK F
10R I=',I4,',KT=',I10,',KI=',I4)
G0 T0 99
261 CALL TERP3(TABK,TABPR,T(L),P(L),CW(L),PR(L),TMINK,TMAXK,DELTK,NTK,
0   1PMINK,PMAXK,DELPK,NPK)
RE(L)=C0N1*D(L)*V(L)/WMU(L)

```

```

HI=HK1*CW(L)*RE(L)**.923*PR(L)**.613
HTC=HI*H0*HK3/(HI*H0+HI*HK3+H0*HK3)
Z=(HTC*RK2+1/DT)/VS
IF(KT-1) 262,262,263
262 THETAK(L)=THETA(L)
263 DT1=(HTC*RK2*T(L)+THETAK(L)/DT)*50./VS-Z*.525E5
265 DT1S=DT1*SFVS
IF(DT1S) 2538,2539,2539
2539 XY=DT1S+.5
G0 T0 2540
2538 XY=DT1S-.5
2540 DT2=Z*1.E4
DT2S=DT2*SFVS
YZ=DT2S+.5
IDV1(3)=IFLX(XY)
IDV1(4)=IFLX(YZ)
C CHECK ANALØG CØMPUTER FØR HØLD MØDE.
266 IF(ITEST(IE,0,15)) 266,266,267
267 CØNTINUE
C RESET CLEAR BIT, BIT 15.
CALL SETWD(0,40)
C READ THE SALT TEMP. AND THE WATER VELØCITY AT X STATION L.
CALL ADDR(6260,IAB4)
CALL SCANH(IAB4,IVTHET,2)
V(L)=IVTHET(1)*1.E-2/SFV
THETA(L)=IVTHET(2)*2.E-2+1050.
IF(KI-M) 269,268,268
268 THETAK(L)=THETA(L)
VK(L)=V(L)
269 CØNTINUE
C SET CØEFFICIENT DEVICES FØR NEXT SPACE INCREMENT.
CALL SETBB4
C PUT THE RIGHT TØ LEFT INTEGRATØRS IN THE ØP MØDE.
CALL SETWD(0,44)
115 CØNTINUE
C LET INTEGRATION PRØCEED WITH DERIVATIVES AT STATION 1,TØ GET
C VALUES AT LEFT BØUNDARY.
C CHECK FØR INTEGRATØR HØLD MØDE.
243 IF(ITEST(IE,0,15)) 243,243,244
244 CALL ADDR(6260,IAB4)
CALL SCANH(IAB4,IVTHET,2)
VLB=IVTHET(1)*1.E-2/SFV
THETLB=IVTHET(2)*2.E-2+1050.
IF(KI-M) 152,153,153
153 VKLB=VLB
C G0 TØ HØLD MØDE ØN SALT TEMP. T-H AMPLIFIER.
CALL SETLI(IE,0,10,0)
C READ THE VALUES ØF T(N),P(N),V(N),ANDD(N),AND SET THEIR
C VALUES ØN T-H AMPLIFIERS.
TEMPØ=T(N)*5.0
IØUTV(1)=IFLX(TEMPØ)
PØUT=P(N)*2.0
IØUTV(2)=IFLX(PØUT)
VØUT=V(N)*50.
IØUTV(3)=IFLX(VØUT)
DØUT=D(N)*1.E3
IØUTV(4)=IFLX(DØUT)
DØ 3111 L=1,4
3111 CALL STIND(IE,IØUTA(L),IØUTV(L))
152 CØNTINUE
DØ 600 LL=1,N
STØR=V(LL)
V(LL)=ALF*V(LL)+(1.-ALF)*VL(LL)
VL(LL)=STØR
STØR=THETA(LL)
THETA(LL)=ALF*THETA(LL)+(1.-ALF)*THETAL(LL)

```

```

600 THETA(L)=STOR
C IF LESS THAN M'TH ITERATION, GO TO NEXT ITERATION.
C   IF M'TH ITERATION, WAIT FOR END OF TIME STEP.
C   RESET DELTA T TIMER AND PROCEED WITH NEXT TIME STEP.
   IF(KI-M) 1000,2000,2000
2000 KX= ITEST(IE,O,14)
C   HAS TIME STEP TIMER TIMED OUT?
   IF(ITEST(IE,O,14)) 2002,2002,2001
2001 WRITE(IW,2010)
2010 FORMAT(IX,'THE COMPUTER TIME REQUIRED PER TIME STEP EXCEEDS
   !THE DELTA T ALLOWED.')
   GO TO 99
C   WAIT FOR TIME STEP TIMER TO TIME OUT.
2002 IF(ITEST(IE,O,14)) 2002,2002,2004
C   PUT SALT TEMP. T-H AMPLIFIER IN TRACK MODE.
2004 CALL SETLI(IE,O,10,1)
   GO TO 2003
99 RETURN
   END
   SUBROUTINE TERP2(TAB,X,Y,VAL,X1,XN,DX,NX,Y1,YN,DY,NY)
   DIMENSION TAB(NX,NY)
   CALL FRAC1(X1,XN,DX,IX,FRX,X)
   CALL FRAC1(Y1,YN,DY,IY,FRY,Y)
   VAL=TAB(IX,IY)*(1.-FRX)*(1.-FRY)+TAB(IX,IY+1)*(1.-FRX)*FRY+TAB(IX+
0  11,IY)*FRX*(1.-FRY)+TAB(IX+1,IY+1)*FRX*FRY
   RETURN
   END
   SUBROUTINE FRAC1(X1,XN,DX,IX,FRX,X)
   DUNIT=(X-X1)/DX
   IX=IF IX(DUNIT)+1
   FRX=DUNIT+1.-IX
   RETURN
   END
   SUBROUTINE TERP3(TB1,TB2,X,Y,VL1,VL2,X1,XN,DX,NX,Y1,YN,DY,NY)
   DIMENSION TB1(NX,NY),TB2(NX,NY)
   CALL FRAC1(X1,XN,DX,IX,FRX,X)
   CALL FRAC1(Y1,YN,DY,IY,FRY,Y)
   A1=(1.-FRX)*(1.-FRY)
   A2=FRX*(1.-FRY)
   A3=FRX*FRY
   A=FRY*(1.-FRX)
   VL1=TB1(IX,IY)*A1+TB1(IX+1,IY)*A2+TB1(IX+1,IY+1)*A3+TB1(IX,IY+1)*A
0  VL2=TB2(IX,IY)*A1+TB2(IX+1,IY)*A2+TB2(IX+1,IY+1)*A3+TB2(IX,IY+1)*A
0  RETURN
   END
*
```

```

TITLE SETBB1
ENTRY SETBB1
EXTERN VALU1,ADDRS1,NSEQ1
SETBB1:  O
        MOVN  1,NSEQ1
        DATA0 700,[22]
        DATA0 704,@ADDRS1
        DATA0 700,[33]
JBF2:   DATA0 704,@VALU1
        A0JL  1,JBF2
        DATA0 700,[30]
        DATA0 704,[7]
        JRA  16,(16)
        END
TITLE SETBB2
ENTRY SETBB2
EXTERN VALU2,ADDRS2,NSEQ2
SETBB2:  O
        MOVN  1,NSEQ2
        DATA0 700,[22]
        DATA0 704,@ADDRS2
        DATA0 700,[33]
JBF2:   DATA0 704,@VALU2
        A0JL  1,JBF2
        DATA0 700,[30]
        DATA0 704,[7]
        JRA  16,(16)
        END
TITLE SETBB3
ENTRY SETBB3
EXTERN VALU3,ADDRS3,NSEQ3
SETBB3:  O
        MOVN  1,NSEQ3
        DATA0 700,[22]
        DATA0 704,@ADDRS3
        DATA0 700,[33]
JBF2:   DATA0 704,@VALU3
        A0JL  1,JBF2
        DATA0 700,[30]
        DATA0 704,[7]
        JRA  16,(16)
        END
TITLE SETBB4
ENTRY SETBB4
EXTERN VALU4,ADDRS4,NSEQ4
SETBB4:  O
        MOVN  1,NSEQ4
        DATA0 700,[22]
        DATA0 704,@ADDRS4
        DATA0 700,[33]

```

```

JBF2:  DATA0  704,@VALU4
      A0JL   1,JBF2
      DATA0  700,[30]
      DATA0  704,[7]
      JRA   16,(16)
      END

      TITLE  PREB1
      ENTRY  PREB1
      EXTERN ARGTRN
      INTERN VALU1,ADDRS1,NSEQ1
PREB1:  O
      MOVEM  1,SAV+1
      MOVEM  0,SAV
      MOVE   0,@2(16)
      MOVEM  0,NSEQ1#
      JSR   ARGTRN
      JUMP  0,0
      ADD   1,NSEQ1
      HRRM  1,ADDRS1
      JSR   ARGTRN
      JUMP  0,1
      ADD   1,NSEQ1
      HRRM  1,VALU1
      MOVE  0,SAV
      MOVE  1,SAV+1
      JRA   16,3(16)
SAV:    BLOCK  2
VALU1:  000001000000
ADDRS1: 000001000000
      END

      TITLE  PREB2
      ENTRY  PREB2
      EXTERN ARGTRN
      INTERN VALU2,ADDRS2,NSEQ2
PREB2:  O
      MOVEM  1,SAV+1
      MOVEM  0,SAV
      MOVE   0,@2(16)
      MOVEM  0,NSEQ2#
      JSR   ARGTRN
      JUMP  0,0
      ADD   1,NSEQ2
      HRRM  1,ADDRS2
      JSR   ARGTRN
      JUMP  0,1
      ADD   1,NSEQ2
      HRRM  1,VALU2
      MOVE  0,SAV
      MOVE  1,SAV+1
      JRA   16,3(16)

```

```

SAV:      BLØCK  2
VALU2:    000001000000
ADDRS2:   000001000000
          END
          TITLE PREB3
          ENTRY PREB3
          EXTERN ARGTRN
          INTERN VALU3,ADDRS3,NSEQ3
PREB3:    0
          MØVEM  1,SAV+1
          MØVEM  0,SAV
          MØVE   0,@2(16)
          MØVEM  0,NSEQ3#
          JSR ARGTRN
          JUMP  0,0
          ADD   1,NSEQ3
          HRRM  1,ADDRS3
          JSR ARGTRN
          JUMP  0,1
          ADD   1,NSEQ3
          HRRM  1,VALU3
          MØVE  0,SAV
          MØVE  1,SAV+1
          JRA   16,3(16)
SAV:      BLØCK  2
VALU3:    000001000000
ADDRS3:   000001000000
          END
          TITLE PREB4
          ENTRY PREB4
          EXTERN ARGTRN
          INTERN VALU4,ADDRS4,NSEQ4
PREB4:    0
          MØVEM  1,SAV+1
          MØVEM  0,SAV
          MØVE   0,@2(16)
          MØVEM  0,NSEQ4#
          JSR ARGTRN
          JUMP  0,0
          ADD   1,NSEQ4
          HRRM  1,ADDRS4
          JSR ARGTRN
          JUMP  0,1
          ADD   1,NSEQ4
          HRRM  1,VALU4
          MØVE  0,SAV
          MØVE  1,SAV+1
          JRA   16,3(16)
SAV:      BLØCK  2
VALU4:    000001000000
ADDRS4:   000001000000
          END

```

*

7.2.2 Steam Generator Equation Variables

ALF	Weighting variable.
AT	Area of steam throttle opening, normalized to a value of 1.0 for design point.
C	Coefficient of friction.
CFCON	Normalization constant in the steam throttle equation.
CONT	Normalization constant used in the Reynolds number formula.
CW	Coefficient of friction of water.
CWLB	Coefficient of friction of water at the left boundary.
CWRB	Coefficient of friction of water at the right boundary.
D	Water density.
DELHD	Spacing of enthalpy points in TABD.
DELPD	Spacing of pressure points in TABD.
DELPH	Spacing of pressure points in TABH.
DELPK	Spacing of pressure points in TABK.
DELPM	Spacing of pressure points in TABMU.
DELPP	Spacing of pressure points in TABPR.
DELPT	Spacing of pressure points in TABT.
DELTH	Spacing of temperature points in TABH.
DELTK	Spacing of temperature points in TABK.
DELTM	Spacing of temperature points in TABMU.
DELTP	Spacing of temperature points in TABPR.

DELTT	Spacing of enthalpy points in TABT.
DH1	Terms of dH/dX not containing H.
DH1S	Analog computer scaled value of DH1.
DH1LB	DH1 at left boundary.
DH1LBS	Analog computer scaled value of DH1LB.
DH2	Terms of dH/dX containing H (feedback).
DH2S	Analog computer scaled value of DH2.
DH2LB	DH2 at left boundary.
DH2LBS	Analog computer scaled value of DH2LB.
DK	Water density for the immediately preceding time step.
DLB	Water density at the left boundary.
DOUT	Water density at the water outlet of the steam generator.
DT	Length of time in each calculational time step.
DT1	Terms of $d(\text{THETA})/dX$ not containing THETA.
DT1S	Analog computer scaled value of DT1.
DT1RB	DT1 at right boundary.
DT1RBS	Analog computer scaled value for DT1RB.
DT2	Terms of $d(\text{THETA})/dX$ containing THETA (feedback).
DT2S	Analog computer scaled value for DT2.
DT2RB	DT2 at right boundary.
DT2RBS	Analog computer scaled value for DT2RB.
DV1	Terms of dV/dX not containing V.

DV2	Terms of dV/dX containing V (feedback).
DV1RB	DV1 at right boundary.
DV1RBS	Analog computer scaled value for DV1RB.
DX	Distance in the direction of water flow, X , between coefficient update stations.
H	Water enthalpy.
HI	The film heat transfer coefficient on the inside of the tube wall.
HILB	HI at left boundary.
HIRB	HI at right boundary.
HK	The value of H for the immediately preceding time step.
HK1	Constant used in calculation of HI.
HK2	Constant used in calculation of HO.
HK3	Heat transfer coefficient of tube wall.
HL	The value of H for the immediately preceding time step.
HLB	H at left boundary.
HLBS	Analog computer scaled value for HLB.
HMAXD	The maximum value of H in TABD.
HMAXT	The maximum value of H in TABT.
HMIND	The minimum value of H in TABD.
HMINT	The minimum value of H in TABT.
HO	The film heat transfer coefficient on the outside tube wall.
HSF	Scale factor for DH1.
HTC	The overall heat transfer coefficient (salt to water).

HTCLB	HTC at left boundary.
HTCRB	HTC at right boundary.
IAR	An array of values read from the analog computer.
IDH	An array of values to be set on specified coeff. devices on the analog computer.
IDH1	An array of values to be set on specified coefficient devices on the analog computer.
IDV	An array of values to be set on specified coefficient devices on the analog computer.
IDV1	An array of values to be set on specified coeff. devices on the analog computer.
ILB	An array of values read from the analog computer (PLB, TLB, and VS).
IOUTA	An array of analog computer addresses.
IOUTV	An array of values to be read from the analog computer, using the addresses in IOUTA.
IR	The device number of the reading device.
IT	The code number used to set the analog computer time scale.
IVTHET	An array of values to be read from the analog computer.
IW	The device number of the output device.
KI	Iteration count variable.
KT	Time step count variable.
KX	Dummy variable.
M	Number of iterations per time step.
N	Number of coefficient update stations in the X direction.

NHD	Number of enthalpy grid points in TABD.
NPD	Number of pressure grid points in TABD.
NPH	Number of pressure grid points in TABH.
NPK	Number of pressure grid points in TABK.
NPM	Number of pressure grid points in TABMU.
NPP	Number of pressure grid points in TABPR.
NPT	Number of pressure grid points in TABT.
NTH	Number of temperature grid points in TABH.
NTK	Number of temperature grid points in TABK.
NTM	Number of temperature grid points in TABMU.
NTP	Number of temperature grid points in TABPR.
NTT	Number of enthalpy grid points in TABT.
P	Water pressure.
PHLB	H at the left boundary for the immediately preceding time step.
PK	Constant in dP/dX .
PKF	Constant in dP/dX .
PL	Water pressure value for the immediately preceding time step.
PLB	Water pressure at the left boundary.
PMAXD	Maximum pressure in TABD.
PMAXH	Maximum pressure in TABH.
PMAXK	Maximum pressure in TABK.
PMAXM	Maximum pressure in TABMU.

PMAXP	Maximum pressure in TABPR.
PMAXT	Maximum pressure in TABT.
PMIND	Minimum pressure in TABD.
PMINH	Minimum pressure in TABH.
PMINK	Minimum pressure in TABK.
PMINM	Minimum pressure in TABMU.
PMINP	Minimum pressure in TABPR.
PMINT	Minimum pressure in TABT.
PR	Prandtl number.
PRLB	Prandtl number at left boundary.
PRRB	Prandtl number at right boundary.
POUT	Water pressure at steam generator outlet.
RE	Reynolds number.
RELB	Reynolds number at left boundary.
RERB	Reynolds number at right boundary.
RK1	Constant.
RK2	Constant.
SFH	Scale factor for H.
SFV	Scale factor for throttle area.
SFVS	Scale factor for VS.
SVT	Scaled throttle area.
T	Water temperature.

TABD	Table expressing water density as a function of P and H.
TABH	Table expressing water enthalpy as a function of P and T.
TABK	Table expressing thermal conductivity of water as a function of P and T.
TABMU	Table expressing viscosity of water as a function of P and T.
TABPR	Table expressing the Prandtl number of water as a function of P and T.
TABT	Table expressing water temperature as a function of P and H.
TEMPO	Water temperature at steam generator outlet.
THETA	Secondary salt temperature.
THETAK	Secondary salt temperature at the immediately preceding time step.
THETK1	Secondary salt temperature at the left boundary for the immediately preceding time step.
THETLB	Secondary salt temperature at the left boundary.
TLB	Water temperature at the left boundary.
TMAXH	Maximum temperature in TABH.
TMAXK	Maximum temperature in TABK.
TMAXM	Maximum temperature in TABMU.
TMAXP	Maximum temperature in TABPR.
TMINH	Minimum temperature in TABH.
TMINK	Minimum temperature in TABK.
TMINM	Minimum temperature in TABMU.
TMINP	Minimum temperature in TABPR.
V	Water velocity.

VK	Water velocity value for the immediately preceding time step.
VKLB	VK at left boundary.
VLB	Water velocity at left boundary.
VOUT	Water velocity at steam generator outlet (water).
VS	Secondary salt velocity.
VT	Water velocity at throttle.
WMU	Water viscosity.
WMULB	Water viscosity at left boundary.
WMURB	Water viscosity at right boundary.

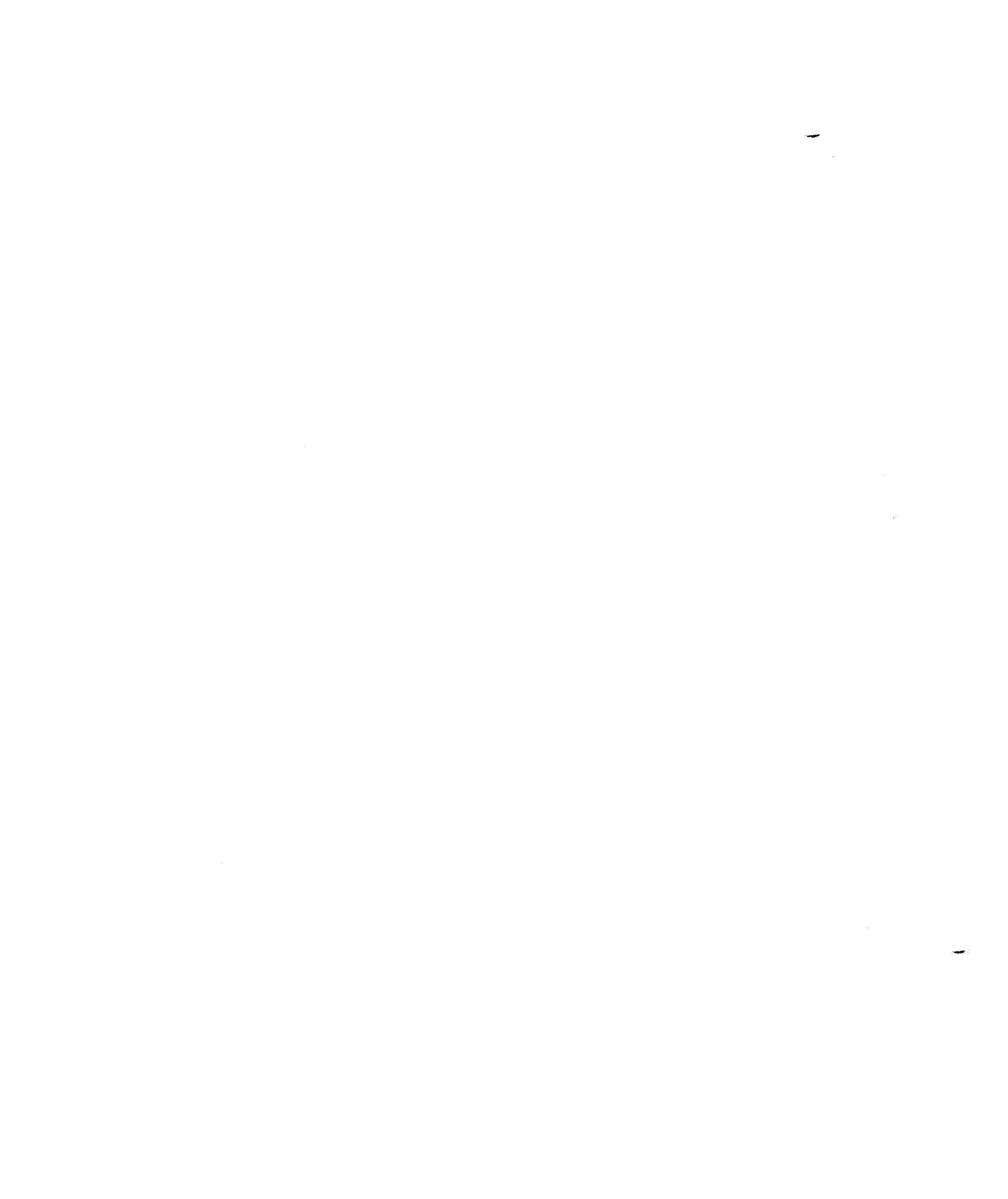

INTERNAL DISTRIBUTION

- | | |
|-----------------------|--------------------------------------|
| 1. J. L. Anderson | 37. T. W. Kerlin |
| 2. C. F. Baes | 38. J. J. Keyes |
| 3. S. J. Ball | 39. Kermit Laughon |
| 4. H. F. Bauman | 40. M. I. Lundin |
| 5. S. E. Beall | 41. H. G. McPherson |
| 6. M. Bender | 42. R. E. McPherson |
| 7. C. E. Bettis | 43. H. E. McCoy |
| 8. E. S. Bettis | 44. H. A. McLain |
| 9. E. G. Bohlmann | 45. L. E. McNeese |
| 10. R. S. Booth | 46. J. R. McWherter |
| 11. C. J. Borkowski | 47. R. L. Moore |
| 12. G. E. Boyd | 48. E. L. Nicholson |
| 13. R. B. Briggs | 49. L. C. Oakes |
| 14-18. O. W. Burke | 50. A. M. Perry |
| 19. O. B. Cavin | 51. T. W. Pickel |
| 20. N. E. Clapp, Jr. | 52-53. M. W. Rosenthal |
| 21. F. H. Clark | 54. G. S. Sadowski |
| 22. D. F. Cope | 55. Dunlap Scott |
| 23. J. L. Crowley | 56. W. H. Sides, Jr. |
| 24. F. L. Culler | 57. M. J. Skinner |
| 25. J. R. Distefano | 58. R. S. Stone |
| 26. S. J. Ditto | 59. J. R. Tallackson |
| 27. W. P. Eatherly | 60. R. E. Thoma |
| 28. J. R. Engel | 61. D. B. Trauger |
| 29. D. E. Ferguson | 62. A. M. Weinberg |
| 30. L. M. Ferris | 63. J. R. Weir |
| 31. W. R. Grimes | 64. J. C. White--A. S. Meyer |
| 32. A. G. Grindell | 65-66. Central Research Library |
| 33. P. N. Haubenreich | 67. Document Reference Section |
| 34. R. E. Helms | 68-69. Laboratory Records Department |
| 35. W. H. Jordan | 70. Laboratory Records, ORNL R. C. |
| 36. P. R. Kasten | |

EXTERNAL DISTRIBUTION

71. John F. Cox, Nuclear Department, Foster Wheeler Corporation, 110 South Orange Avenue, Livingston, N. J. 07039
72. C. B. Deering, Black and Veatch Engineers, 1500 Meadowlake Parkway, Kansas City, Missouri 64114
73. Ronald Feit, Instrumentation and Control Branch, Division of Reactor Development and Technology, U. S. Atomic Energy Commission, Washington, D. C. 20545
74. George McCright, Black and Veatch Engineers, 1500 Meadowlake Parkway, Kansas City, Missouri 64114
- 75-76. T. W. McIntosh, Division of Reactor Development and Technology, U. S. Atomic Energy Commission, Washington, D. C. 20545

77. H. G. O'Brien, Tennessee Valley Authority, 210A Union Building, Knoxville, Tennessee 37902
78. M. Shaw, Division of Reactor Development and Technology, U. S. Atomic Energy Commission, Washington, D. C. 20545
79. C. S. Walker, Tennessee Valley Authority, Union Building, Knoxville, Tennessee 37902
80. J. R. Trinko, Ebasco Services Incorporated, 2 Rector Street, New York, N. Y. 10006
81. Research and Technical Support Division, AEC, ORO
- 82-83. Division of Technical Information Extension